

rotork

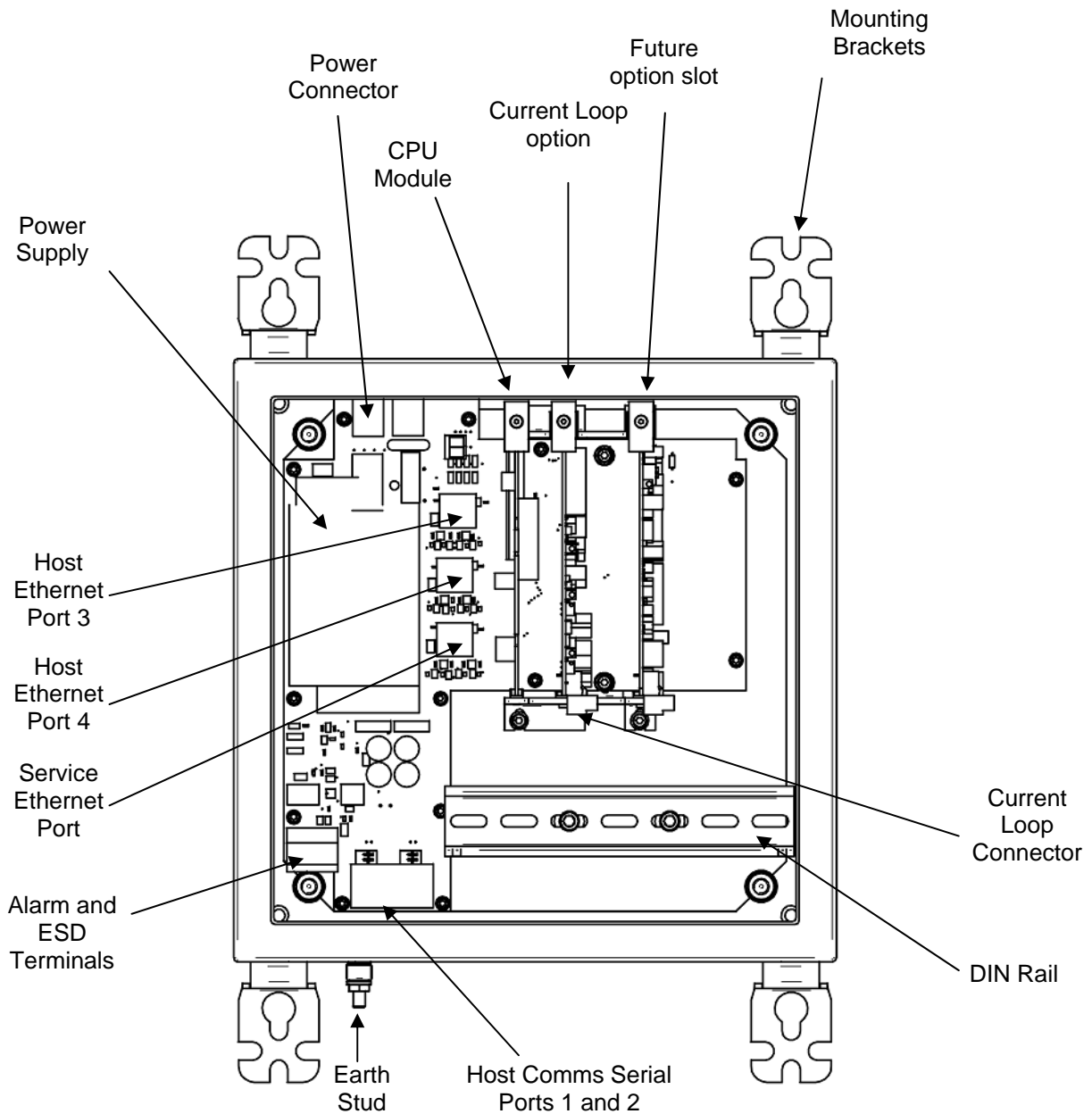

**P3F - PAKSCAN FIELD MOUNT
MASTER STATION
TECHNICAL MANUAL**

KNOW YOUR MASTER STATION



View with door open

Contents:

KNOW YOUR MASTER STATION2

INTRODUCTION5

1. MOUNTING AND CONNECTING THE MASTER STATION.....7

 1.1 Mechanical Fixing7

 1.2 Serial Comms Connections8

 1.3 Ethernet Comms Connections8

 1.4 Power Connector and Fuse.....8

 1.5 ESD and Alarm Output Connector9

 1.6 Current Loop Connections.....9

2. THE FIELD NETWORK 11

 2.1 Loop Checks.....11

 2.1 Loop Checks.....12

 2.2 Connecting Up.....12

3. SORTING OUT THE SERIAL COMMS LINKS..... 15

 3.1 Setting Port 1 and 2 for RS232 or RS485.....15

 3.2 When to Use RS23217

 3.3 When to Use RS48517

4. USING ETHERNET HOST COMMS..... 19

 4.1 Setting-Up the Ethernet Comms.....19

5. THE INTERNAL WEB PAGES21

 5.1 Making an Internet / intranet Connection21

 5.2 Connecting a Laptop Directly to the Master Station21

 5.3 5.3 Adjusting the Network Settings of the Laptop / PC.....21

 5.3 5.3 Adjusting the Network Settings of the Laptop / PC.....22

 5.4 Web Page Structure23

 5.4.1 User Levels.....23

 5.4.2 Overall Web Page Layout.....23

 5.5 The Web Pages in Detail.....25

 5.5.1 Log In Screen25

 5.5.2 Master Station25

 5.5.2 Master Station26

 5.5.3 View Configuration28

 5.5.4 System Diagnostics29

 5.5.5 Master Station Data Logger.....30

 5.5.6 Master Station Host Analyser32

 5.5.7 Pakscan 2 Loop Diagnostics33

- 5.5.8 Option Card Event Logger36
- 5.5.9 FCU Menu37
- 5.5.10 FCU Control - IQ/IQT Actuator38
- 5.5.11 FCU Control - Integral Actuator43
- 5.5.12 FCU Control - Flowpak Actuator.....47
- 5.5.13 FCU Control - General Purpose Field Unit.....49
- 5.5.14 FCU Control - Other Field Units52
- 5.5.15 Admin.....54
- 5.5.16 Users54
- 5.5.17 Masterstation Config.....57
- 5.5.18 Host Port Configuration61
- 5.5.19 Alarms.....64
- 5.5.20 Time.....66
- 5.5.21 General.....67
- 5.5.22 Network.....68
- 5.6 Setting Up the Master station Configuration Using the Web Pages.....70**
 - 5.6.1 Master Station Set-up page.....70
 - 5.6.2 Option Module Set-up (including host comms protocols).....72
 - 5.6.3 Host Port Settings.....72
 - 5.6.4 Setting the IP Address.....73
- 6. MAKING THE SYSTEM WORK75**
 - 6.1 Commissioning the System75
 - 6.2 Monitoring and Controlling the Actuators.....76
- GENERAL SAFETY INFORMATION.....79**

***This manual relates to Pakscan P3F Master Stations
fitted with PS720 Current Loop modules***

INTRODUCTION

Pakscan 3 is the latest network control system from Rotork. The Pakscan P3F master station encompasses the P3 technology in a master station specifically designed for mounting in remote locations. The P3F enclosure protects the electronics within to IP65 standards and is suitable for use in those locations where more conventional equipment cannot be located. Compared to the P3, the P3F is simplified to include only those features demanded by smaller and simpler applications. It is a single channel system capable of supporting up to 32 actuators or other field units.

Most types of Rotork actuator can be connected to the Pakscan current loop provided they are fitted with the necessary field unit. Information on the respective actuator field units can be found in the appropriate manuals. In this guide, the type of actuator is not considered, though reference is made to both the Integral and IQ actuator types of field unit. The type of field unit does not affect the setting up of the system.

The P3F master station is supplied as a stand alone unit ready for connection to the actuators and host control system.



Fig 1: The Pakscan P3F Master Station

(This page is intentionally blank)

1. MOUNTING AND CONNECTING THE MASTER STATION

Before fixing the master station in its permanent location, it may be more convenient to set the comms link switches as discussed in section 3.

The Pakscan P3F master station provides front access for all the user connections including power feed and the field loop wires to the Current Loop module (PS720). The host communication uses screw terminal connections for the serial comms and RJ45 connections for the Ethernet links.

- ❑ The field wiring for the loop and the master station alarms is taken to screw terminals on plug in connectors that are fitted from below their appropriate module.
- ❑ Power wiring is connected using a 3-way plug-in connector with screw terminals in the top of the master station main circuit board.
- ❑ Serial comms ports 1 and 2 (RS232 or RS485) connect to an 8-way plug-in connector with screw terminals on the bottom of the main circuit board.
- ❑ Ethernet connections use RJ45 connectors on the main circuit board. The service port connector is intended for connection to a service laptop computer. Host ports 3 and 4 are for permanent Ethernet connections.

1.1 Mechanical Fixing

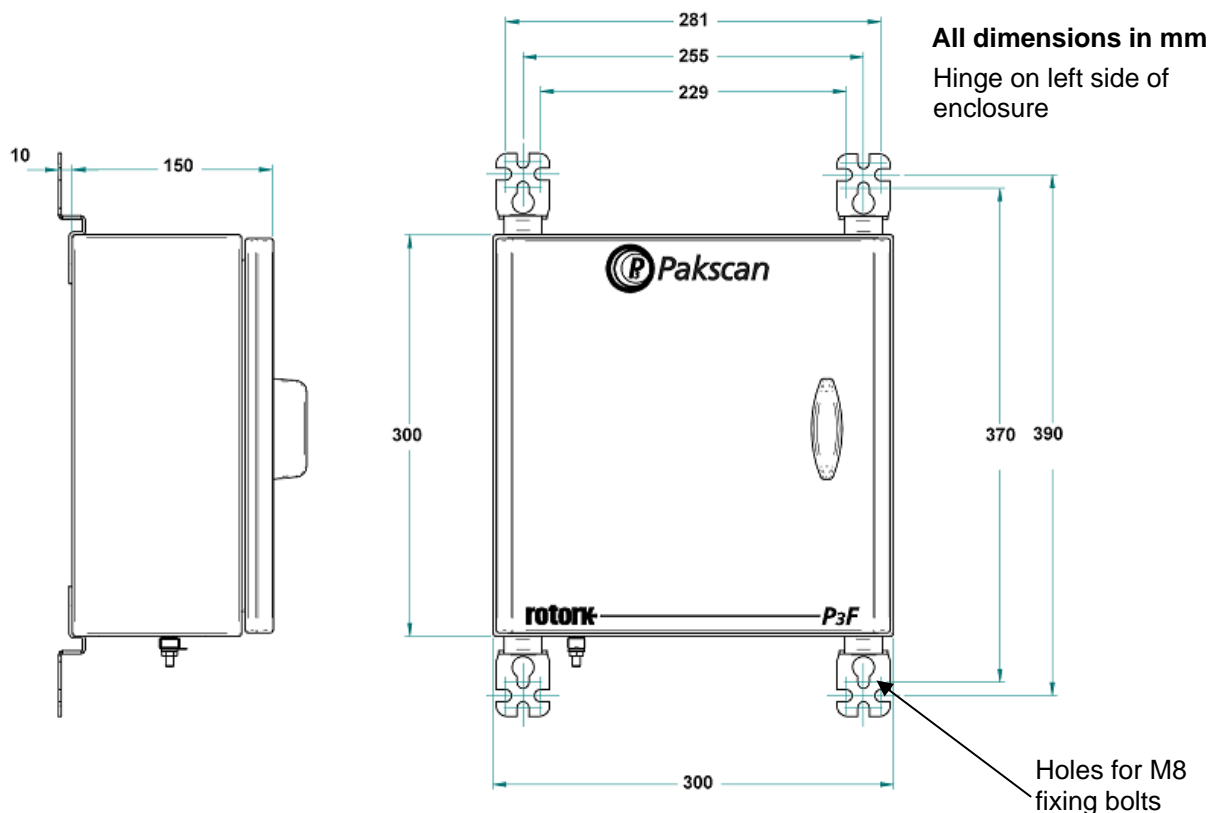

Fig 2: Pakscan 3F surface mounting dimensions.

Room should be left around the enclosure for all the connections and cables, allowing for suitable bending radius on each lead. Power wiring should be suitably fused or protected with a miniature circuit breaker (MCB) external to the master station.

The master station should be mounted on a flat surface using the mounting brackets provided. It should be located in a way that permits easy opening of the front door and access to the internal connectors and modules.

1.2 Serial Comms Connections

The serial data connections are via the Serial Comms terminal block located on the main circuit board below the power supply and to the left of the DIN rail. This connector has screw terminals and plugs in to the mating part fixed on the circuit board. The terminal connections are shown below.

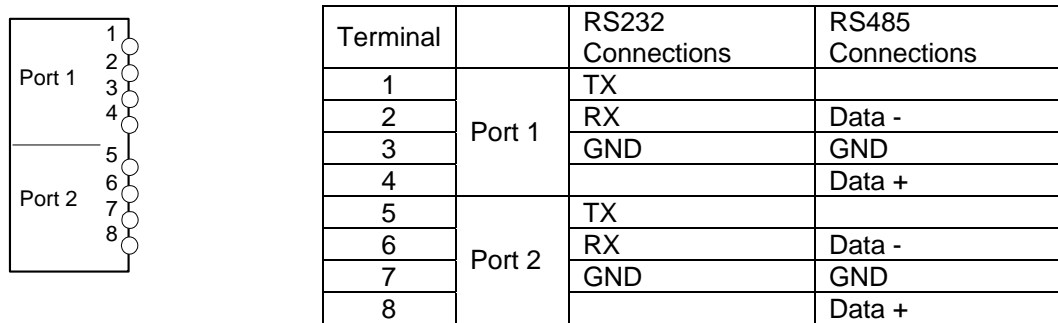

Fig 3: Serial Comms connector terminal functions

- ❑ With RS485 it is possible to arrange a multi-drop data highway for the serial communications, whilst RS232 must be single point comms.

1.3 Ethernet Comms Connections

Each Pakscan P3F master station has 3 x RJ45 Ethernet connectors for the host communication ports and the service port. These are marked Port 3 and Port 4 (host communication ports) and Port 5 (service port). A portable computer (laptop) should be connected to Port 5, the service port, to set up the P3F. Standard Ethernet shielded patch cables should be used with these ports.

1.4 Power Connector and Fuse

The Pakscan P3F has its own internal power supply and a three-way screw terminal connector at the top of the main circuit board is provided to allow the mains power (85 to 265V AC – 47 to 63 Hz) to be connected. The master station power fuse is located just below this connector and should be 250V 1A fuse. For the 24V DC version the same three-way connector is used.

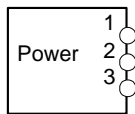

Terminal	ac Connection (85-265V ac)	dc Connection (18-36V dc)
1	N (Neutral)	0 V
2	L (Line)	24 V
3	E (Earth)	Earth

Fig 4: Power connector terminal functions

1.5 ESD and Alarm Output Connector

There is a removable screw terminal connector plugged into the main circuit board of the P3F master station for the connection of ESD hard-wired inputs and for connection to the internal alarm relay contacts, when required. (On most systems these terminals will not be used; in which case a hard-wired link between pins 4 and 5 should be added.)

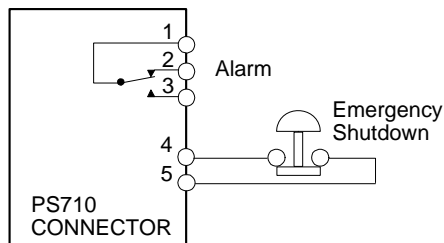

Terminal	Function
1	Alarm (common)
2	Alarm (normally closed)
3	Alarm (normally open)
4	Emergency Shutdown
5	Emergency Shutdown

Note that the relay is shown in the 'Alarm Active' or 'power removed' position.

Fig 5: Alarm/ESD connector terminal functions

1.6 Current Loop Connections

A removable screw terminal connector is located in the bottom of the Current Loop Module for the connection of the Pakscan IIE current loop to the field mounted actuators.

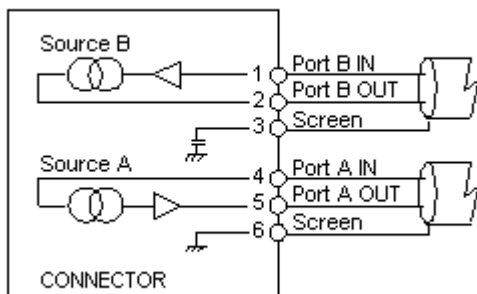

Terminal	Function
1	Port B In
2	Port B Out
3	Port B Screen
4	Port A In
5	Port A Out
6	Port A Screen

Fig 6: Current Loop connections

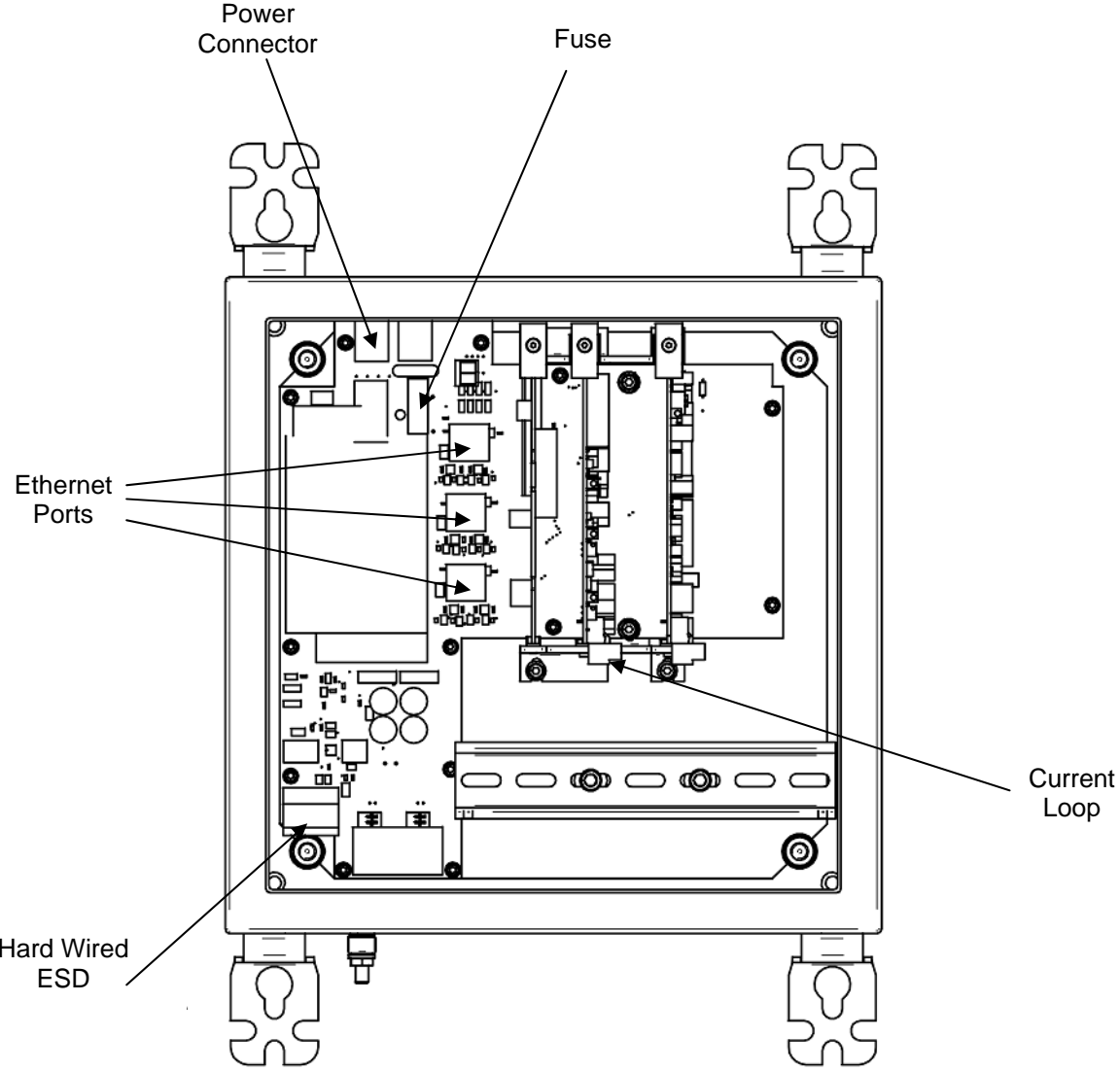

Fig 7: View of the Pakscan P3F master station showing the Connectors and Fuse

2. THE FIELD NETWORK

The Pakscan current loop field network must be correctly cabled and connected to the master station. The values of the field loop resistance and capacitance must be known to determine the loop speed that can be used. If these are not known then the LOWEST loop speed must be set in each actuator and the master station to ensure some field network connectivity.

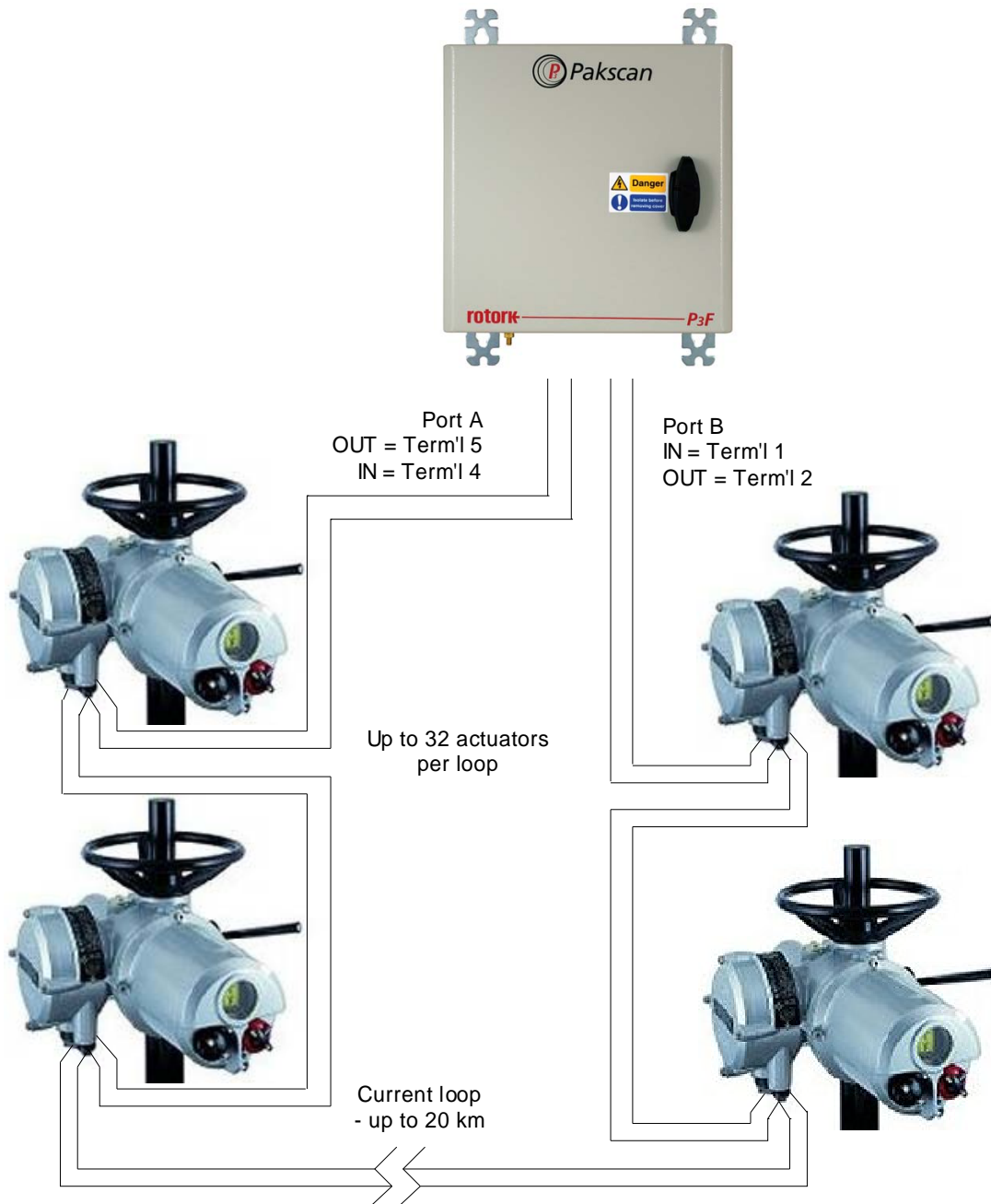

Fig 8: Pakscan P3 Network

2.1 Loop Checks

The most common errors in installing the system occur on the field wiring.

Loop Continuity

With all the field units connected, but none of them powered up, check the continuity of the 2 cores of the cable and measure its resistance.

Screen Continuity

Make sure that the screen is isolated from the loop cores and that the screen is continuous. Ensure the screen is connected to a signal earth bar at only one point or to terminals on the loop driver plug; 3 linked directly to the enclosure earth and 6 linked to the enclosure earth via an internal capacitor. Both the screens must be connected to the terminals provided, so as to ensure the product meets the European Directive on EMC.

Cable Capacitance

The capacitance between the cores, and to the screen, is critical to the system performance. Too high a capacitance for the selected loop baud rate will result in poor communications, or even communication failure.

Maximum Loop Speed

The cable resistance and capacitance must not exceed the permitted maximum values for each communication speed. The limiting values of R and C for each speed will depend on the number of field units actually connected. The following table gives the total figures for systems including the capacitance of the field units. Deduct 2.2nF for each field unit to determine the maximum cable capacitance allowed at each speed.

Baud Rate	R max (ohms)	C max (μ F) ①
110	500	4.5
300	500	2.1
600	500	1.54
1200	500	0.6
2400	500	0.3

① Each field unit will add a capacitance of 2.2nF (0.0022 μ F)
 The C max figure given is the maximum value for the network capacitance including the field unit capacitance.

2.2 Connecting Up

Once the checks are complete, connect the Loop Cables to the PS720 Current Loop module. At this point leave the actuators all without power except for the one furthest from Loop Port A.

Refer to section 6 for commissioning a Pakscan system.

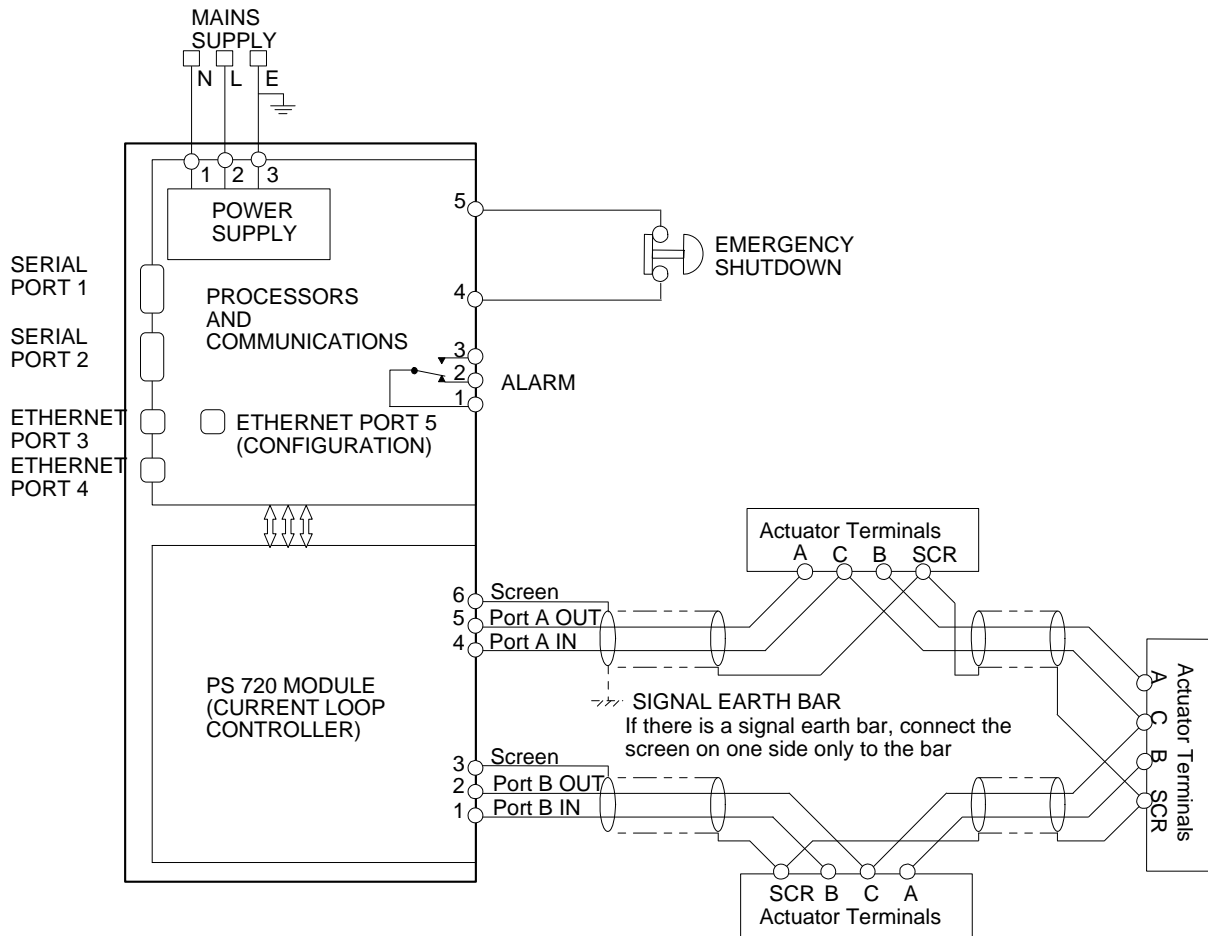

Note: If there is no hard-wired ESD requirement, a shorting link must be fitted across pin 4 and 5 of the 5 pin plug.

Fig 9: Pakscan P3F Current Loop System Block Diagram

(This page is intentionally blank)

3. SORTING OUT THE SERIAL COMMS LINKS

The Pakscan P3F CPU module has two serial ports. Each of these is configurable for RS232 or RS485. Where redundant communications to the host system using serial comms is required, then two RS485 connections are often used.

3.1 Setting Port 1 and 2 for RS232 or RS485

The main circuit board has DIP switches for setting the type of serial port that is presented at the port terminal block.

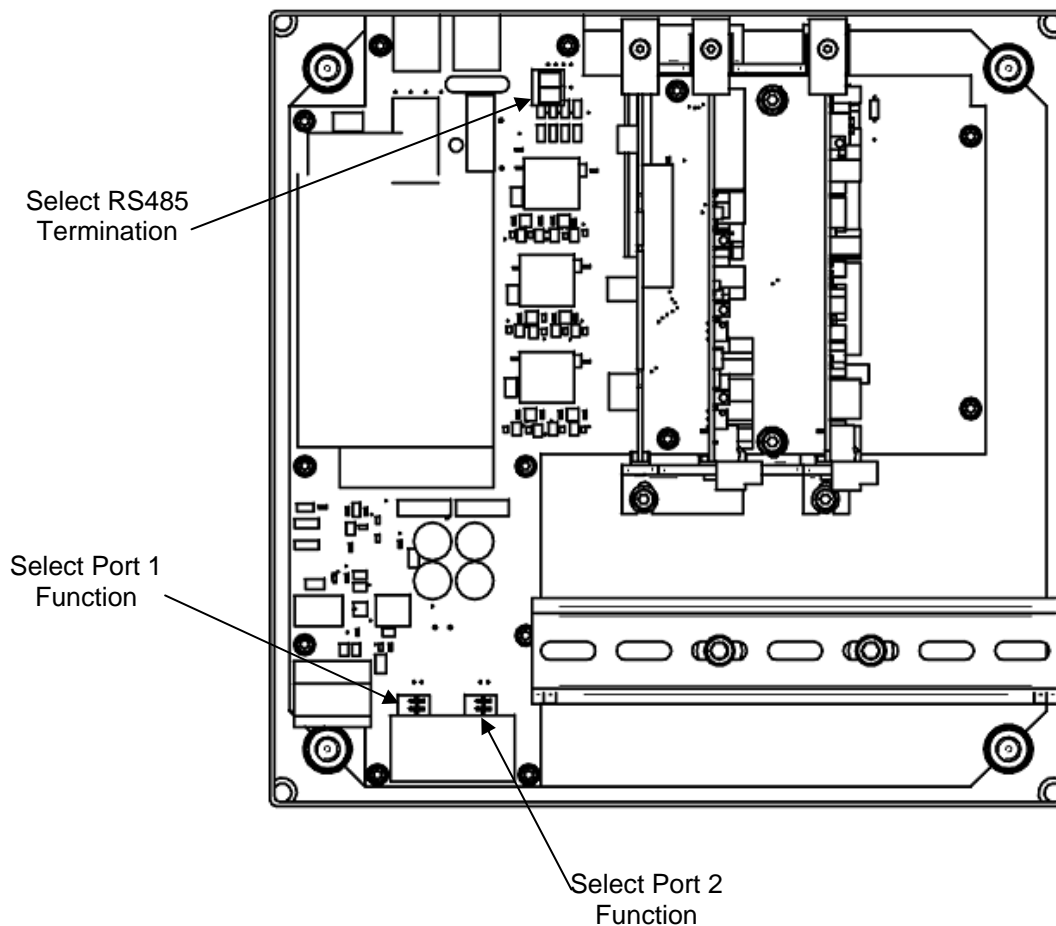

Fig 10: Pakscan P3F Serial related switches

Port Function

The two DIP switches allow each port to be selected between RS232 and RS485. For RS485 slide the appropriate Port switch up, for RS232 they should be down.

Each of the two ports may be set independently.

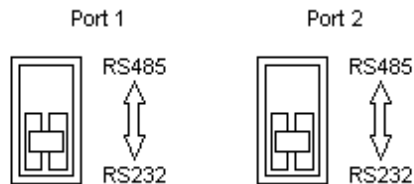

Fig 11: Port Function Switches shown in RS232 position

Port Termination Resistors

The two DIP switches are used to connect end of line termination resistors and biasing resistors to the RS485 network. All RS485 network highways should be terminated at **both ends of the highway**. Each port can be terminated independently.

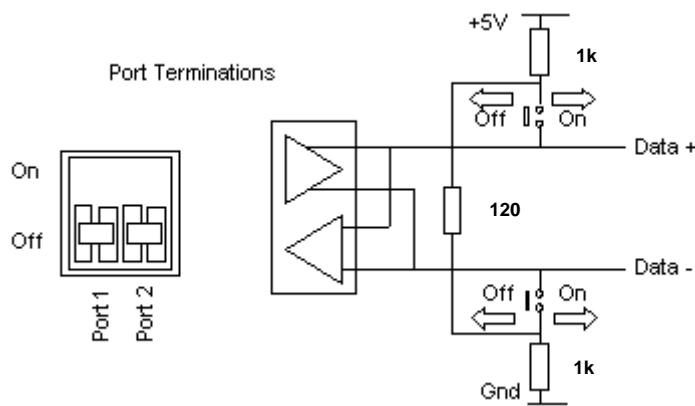

Fig 12: Port Termination Switches shown in Off position

3.2 When to Use RS232

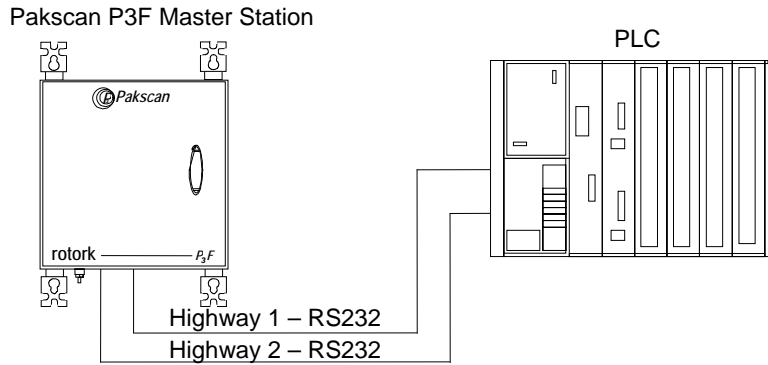

Fig 13: RS232, dual highway, from P3F master station to PLC

When the host PLC or DCS is located near to the Pakscan P3F master station, RS232 comms can be used with single point to point links. Either Port 1 or Port 2 can be used, though most users would use Port 1. Two links can be used if redundant communications are required.

For RS232 on -	Port Terminations	RS232 ↔ RS485
Port 1	Off (Down)	RS232 (Down)
Port 2	Off (Down)	RS232 (Down)

3.3 When to Use RS485

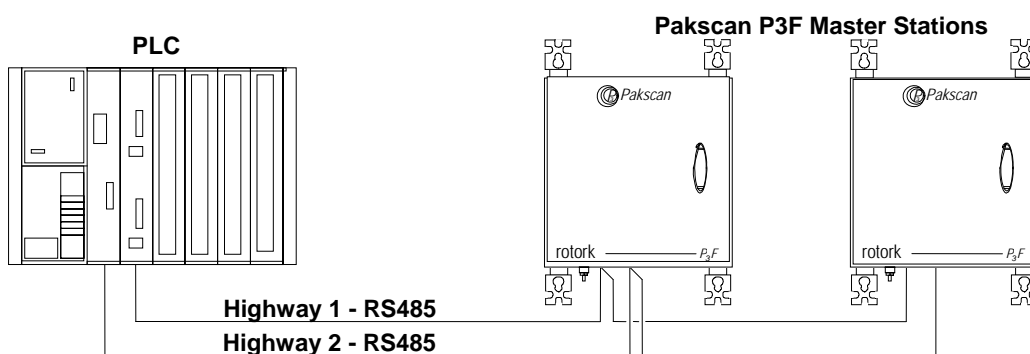

Fig 14: RS485, dual highway, from P3F master stations to PLC

When there are several Pakscan P3F master stations to be connected to the PLC, or the distance between the Host and the master station is more than 20 metres, an RS485 highway will be best. The highway will require a multi-drop configuration, as shown on the diagram. The screw connectors in

the master station make this simple to achieve. When a multi-drop connection is made, care must be taken to ensure that the cable is not broken if a master station is disconnected.

The master station supplies port termination resistors for each port, which can be enabled where required.

For RS485 on -	Port Terminations	RS232 ↔ RS485
Port 1	Off (Down) On (Up)	RS485 (Up)
Port 2	Off (Down) On (Up)	RS485 (Up)

4. USING ETHERNET HOST COMMS

Pakscan P3F master stations come complete with two Ethernet ports for connection to host DCS or PLC systems. A third Ethernet port is also available for connection to a laptop computer for configuration purposes. The master station is ready to use with Ethernet and Modbus TCP protocol for the DCS to access data and control the actuators on the field network. The IP address is already set and can be changed during setting up the master station

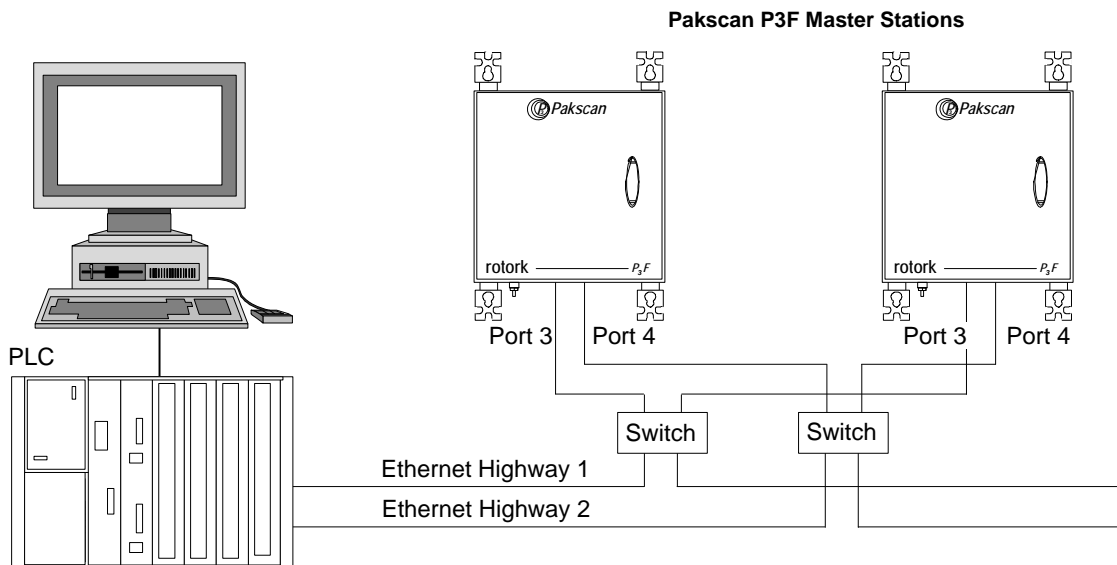

Fig 15: Ethernet, dual highway, from P3F master station to PLC

4.1 Setting-Up the Ethernet Comms

Ethernet connections require 10BaseT or 100baseT Ethernet Switches to connect the system together. Patch cords connect the ports on the master to the Switches. Independent highways are possible by using separate switches on each highway.

The Pakscan P3F master station defaults to the same IP address on both the ports. It is possible to change the IP address, but the two ports always have the same address.

DHCP	Static			
Default IP address	10	200	1	1
Subnet mask	255	255	255	0

The recommended highway organisation is:

- Use two main data highway bus's, each of which connects to all the master stations.
- The master is left with a Static DHCP port setting.
- The master station can serve up to 10 simultaneous host connections.

With this arrangement either PLC port can always communicate with the master station and the devices on the loop. Heartbeat data requests on the second highway will always be acknowledged with a response.

5. THE INTERNAL WEB PAGES

The P3F master station includes a set of Web pages that may be remotely accessed via Ethernet. They can be used for setting up the system, examining the system for any faults or alarms and also for controlling the actuators on the network (provided the Interlock permission is set to allow this feature).

If the master station is connected to an Ethernet Network it will act as a server and any computer within that network can connect to the master station. The master station can also be configured and the field network set up by using these web pages. The host system or PC connected via the Ethernet Network or directly will need a web browser such as Internet Explorer to access the master station web pages

5.1 Making an Internet / intranet Connection

Connect the master station to an Ethernet host as described in section 4, or connect via a suitable router to the internet / intranet. A laptop or PC can be directly connected to port 3 or 4 or to the configuration connector, if there is no network connection available. Details of directly connecting a laptop are contained in the section on setting up with a PC, below.

Start the browser and enter the IP address of the master station. The default address is 10.200.1.1, so the address is **http://10.200.1.1**. The browser will then access the master station and bring up the opening page of the master station. In order to log in as a verified user enter a user name of **admin** and a password of **admin**. (These default names should be altered as soon as convenient to prevent unauthorized access to the system.)

Default IP address	10	200	1	1
Default User	admin			
Default Password	admin			

Once entry to the web pages has been made, if no changes to the display or information is made for 10 minutes, the system will automatically log out and the user/password must be re-entered.

5.2 Connecting a Laptop Directly to the Master Station

The simplest direct connection to the master station is by using the Ethernet port on the front of the main pcb. A standard Ethernet patch cable can be used to link the two directly. The connector will accept either a standard patch cable or a direct link cable that has a twist between the transmit pair and receive pair in the cable. A permanent PC connection can also be made directly to the main Ethernet connector (port 3 or 4). In order to establish a connection it may be necessary to adjust the settings of the Laptop Internet connection.

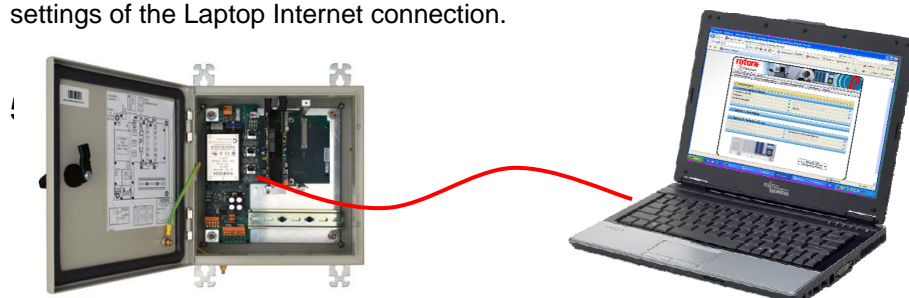

Fig 16: Connecting a Laptop to the Pakscan P3F

5.3 Adjusting the Network Settings of the Laptop / PC

- Ensure nothing is connected to the Ethernet port of the laptop / PC.
- Open the Control Panel and select Network Connections.
- In the 'Network Connections' window, double-click on the 'LAN or High Speed Internet' icon and the 'Local Area Connection Status' window will open.
- Click on the 'Properties' button, and a second window will open. Select 'Internet Protocol TCP/IP' and click on the 'Properties' button in this window.
- The 'Internet Protocol TCP/IP Properties' window will open. Next change the setting to force the Laptop to adopt a fixed IP address and enter an address for the Laptop / PC of 10.200.1.3 and a subnet mask of 255.255.255.0. Click on the OK button and the window will close.
- Click OK on the 'Local Area Connection Properties' window and then Close the status window.
- Finally, close the Network Connections window and the Control Panel.
- It may be necessary to reboot the PC to be sure that the new settings take effect correctly.
- Connect the cable between the PC and the Pakscan master station.

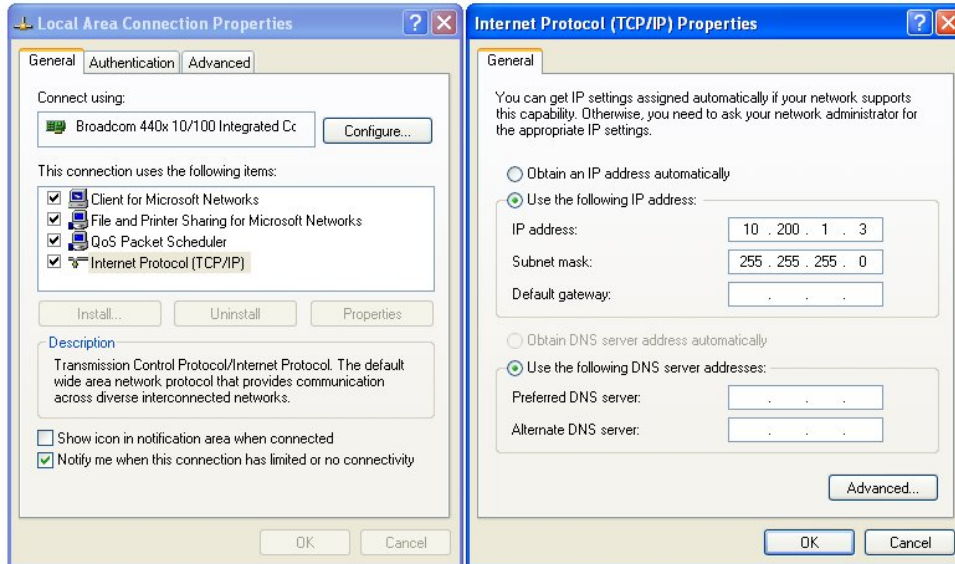

Fig 17: Changing the Network Connections TCP/IP Properties

Start the browser and enter the IP address of the master station. The default address is 10.200.1.1, so the address is **http://10.200.1.1**. The browser will then access the master station and bring up the opening page of the master station. In order to log in as a verified user, enter a username of **admin** and a password of **admin**.

Note that if the IP address of the master station has been changed from the defaults, then the settings above will not work and have to be modified to suit the actual settings.

5.4 Web Page Structure

The web pages have three access levels, each requiring a password with the correct level set. A user enters the web server with a particular degree of access to the functions of the server and the master station.

5.4.1 User Levels

Access Level		Function
Lowest level	Read	Allows access to read master station status and settings, plus the option card status and settings and the actuator and field unit status on the option card network. No commands or alterations to the system are permitted.
	Write	As for read access with the addition of the ability to issue network commands, swap masters and command actuators on the option card network to change position.
Highest Level	Administrator	As for the two lower levels plus the ability to configure the master station, option cards and all system settings. Set and remove user names and passwords, set alarm reporting parameters, change system addresses and test system communications.

The Administrator level sets all other user names and passwords. As soon as the system is set up, the default password should be changed.

5.4.2 Overall Web Page Layout

The web pages are organised using a menu structure with the primary menu on the top of each page. Within a page there are other controls for parameter alteration or to reveal extended information on the topic of the particular page.

Navigation between the pages is by selecting another topic on the main menu.

If there is no activity with the mouse to change the display or update the information or selection for 10 minutes the system automatically logs out the user and the username and password must be re-entered to continue using the pages.

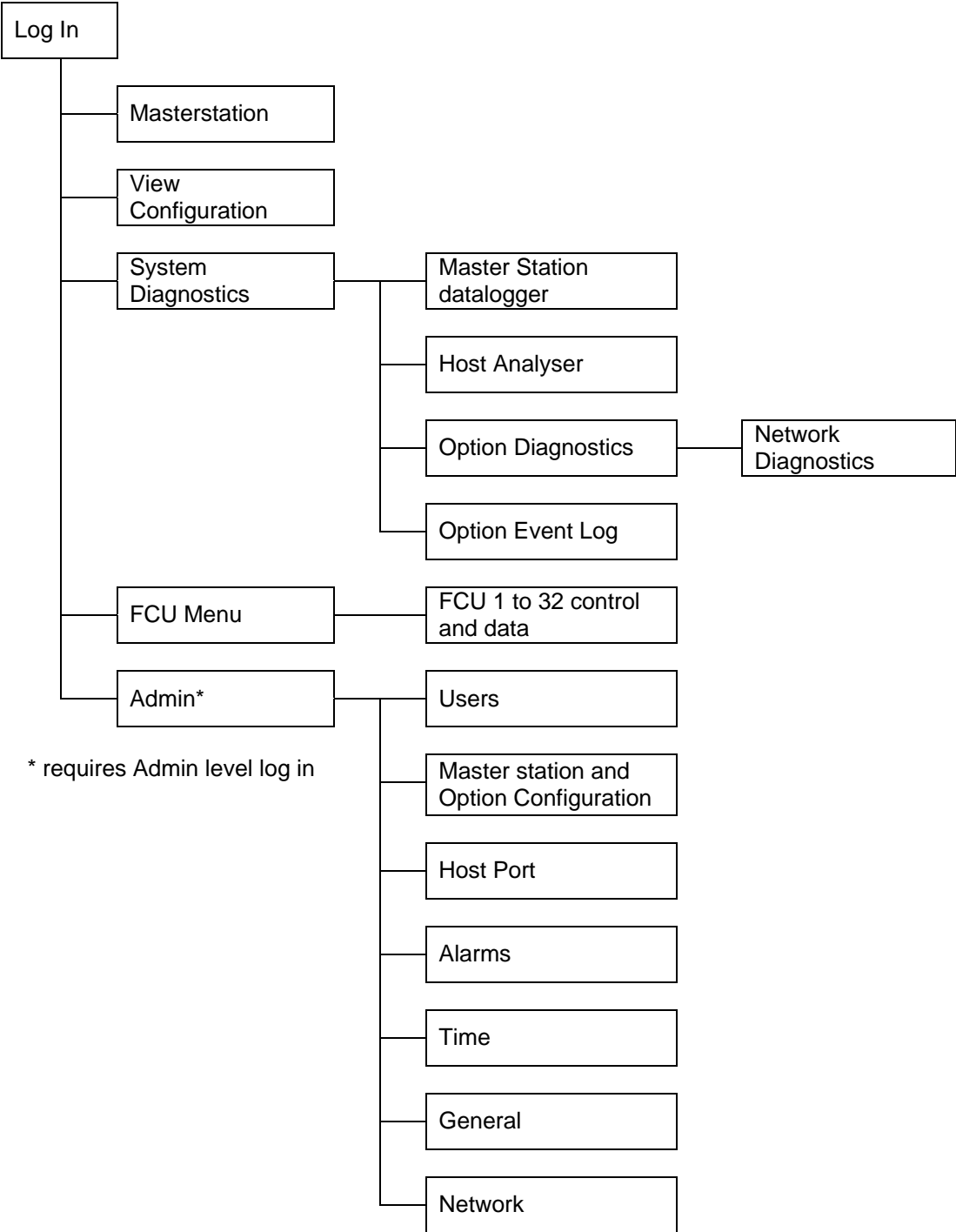

Fig 18: Web Page Menu Layout

5.5 The Web Pages in Detail

5.5.1 Log In Screen



Fig 19: Log In Screen

The first screen is the Log In screen on which the user must enter a **Username** and **Password**.

- ❑ **Username** - a case sensitive identification for an individual or group used to give access to the system. Usernames are listed for administrators to see on the 'Add User' page.
- ❑ **Password** - the case sensitive confirmation required before a username is accepted by the system. Passwords are not listed on any page in the system and cannot be retrieved, even at the administrator level.

Select the box with a mouse and enter the appropriate name or password, then click on the **login** button. The system will move to the next page if the login is accepted, if it fails the data is cleared from the boxes and must be re-entered correctly in both boxes before access is granted.

The default user name is **admin** and password is **admin**. (These default names should be altered as soon as convenient to prevent unauthorized access to the system).

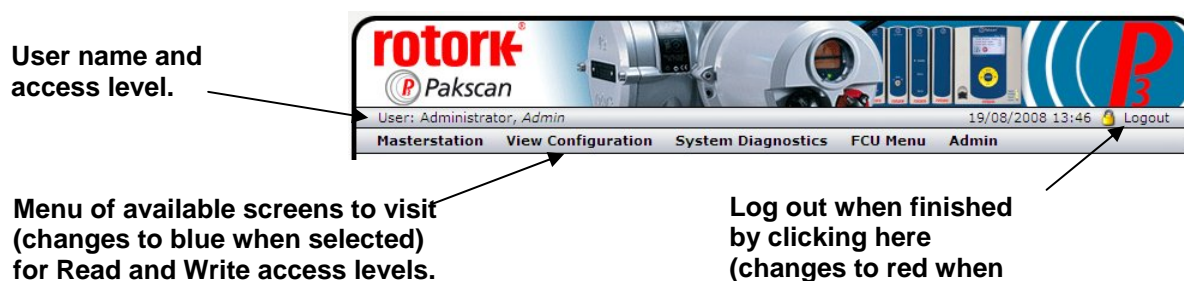

Fig 20: Web Page Header Navigation

5.5.2 Master Station



Fig 21: Master Station Overview Page

This screen is accessible to Read, Write and Administration user levels.

The screen reports the current status of the master station and the option cards fitted. The coloured lights show the condition of the associated parameter. Greyed out text and lights are not applicable or else in a safe (normal) condition.

Master Station CPU Module

- Site name : The name of the site where the system is located as entered during configuration.
- Tag name : The master station tag as entered during configuration.

Status

- Module Health : Indicates the absence (green light) or presence (red light) of a fault on the this CPU.
- ESD Presence : Shows a yellow light if an Emergency Shut Down signal is active.
- Alarm : Indicates the presence of an alarm (red light) somewhere on the system.

Option 1 - Pakscan 2 Loop Option Module

- Loopback in Progress : A blue light shows whilst the master station is reconfiguring the loop.
- Loopback In use : A yellow light shows when the master station has detected a loopback fault on the system.

- Auto Loopback : If a fault occurs on the network and an automatic reconfiguration of the loop occurs, a yellow light is shown here.
- Common Field Unit Alarm : A red light shows if any field unit on the network has an alarm bit present.
- Common Actuator Alarm : A red light shows if any actuator on the network is unavailable due to its monitor relay having tripped.
- ESD Active : If there is any Emergency Shut Down signal present on the system a red light shows.

Controls - Not Available for Read level users

- Network ESD : Click here to issue an ESD to all actuators connected to either option card. The resulting action will depend on the individual actuator settings. A confirmation screen appears to verify or cancel the instruction before the action occurs.

5.5.3 View Configuration

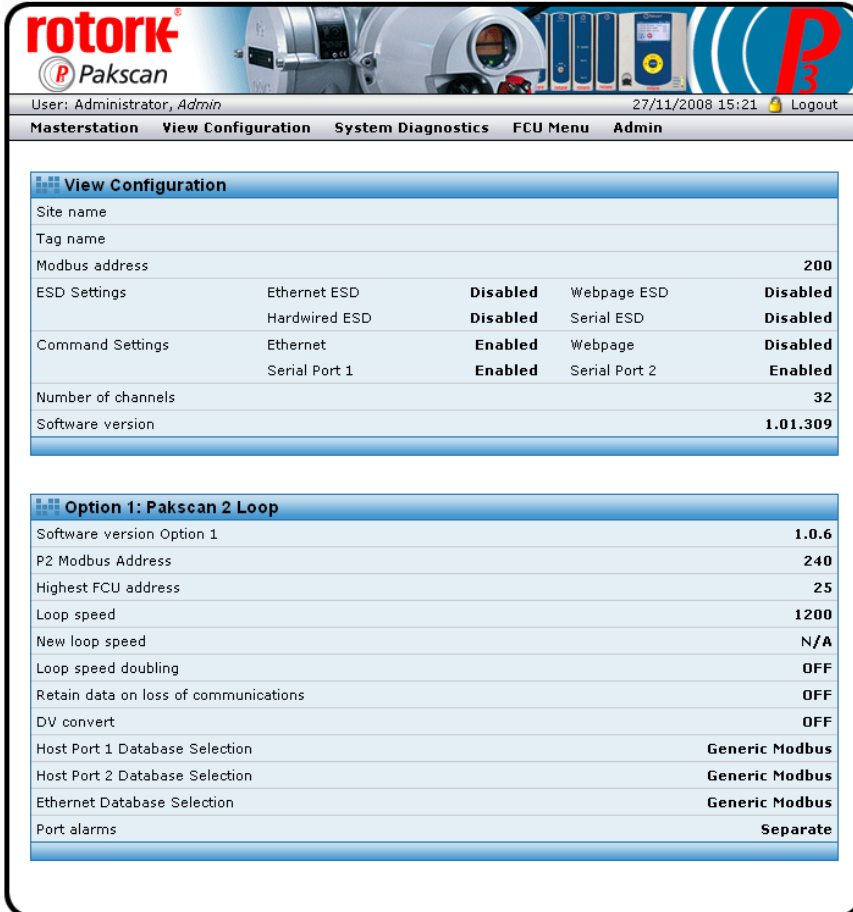

Fig 22: System Configuration Overview Page

This screen is accessible to Read, Write and Administration user levels.

The screen shows the settings for the control of the option card network and the CPU control capability, software fitted and various options selected. All of these settings can be modified, but only by users with Administration level access. There are no controls on this page.

The settings are explained in the Master Station Configuration page section.

5.5.4 System Diagnostics

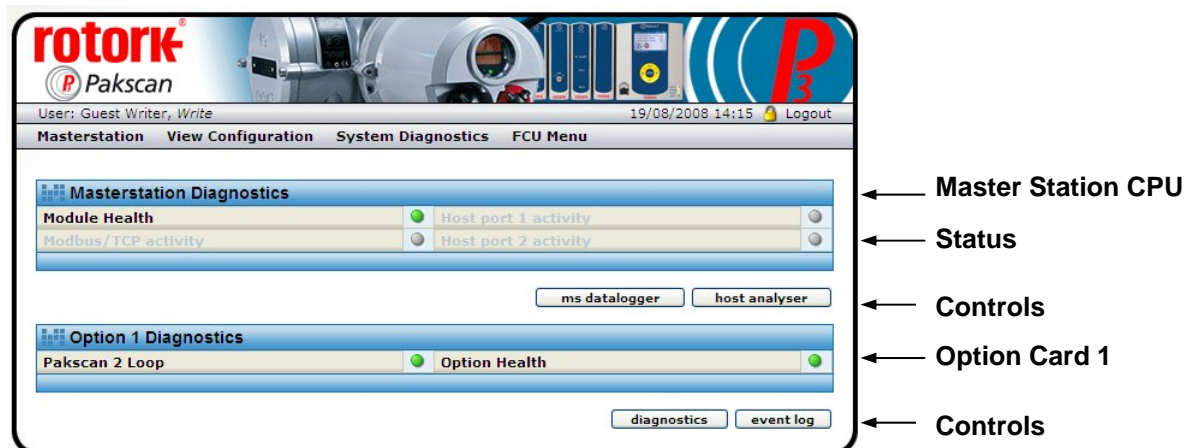

Fig 23: System Diagnostics Page

This screen is accessible to Read, Write and Administration user levels.

The System Diagnostics screen shows an overview of the status of the fitted module and also provides access to further information.

Master Station Diagnostics

- Module Health : A green light shows if the module is operating correctly or a red light if there is a fault.
- Modbus/TCP activity : Indicates when Ethernet control using Modbus/TCP is present on either Ethernet port.
- Host port 1 activity : Indicates when there is active serial communication on comms port 1.
- Host port 2 activity : Indicates when there is active serial communication on comms port 2.

Controls - Available to all user levels

- MS datalogger : Reveals a pop-up showing a log of the activity on the master station and the source of requests or commands received.
- Host analyser : Reveals a pop-up with the data logger data and the additional controls required for using the inbuilt data analyser for commands and data to the host system.

Option 1 Diagnostics

- Pakscan 2 Loop : Shows module type and status.
- Option Health : Shows green light when healthy and red light if there is a fault on the module.

Controls - Available to all user levels

- Diagnostics : Reveals the diagnostic page for the option card fitted.
- Event Log : Shows the option module event recorder.

5.5.5 Master Station Data Logger

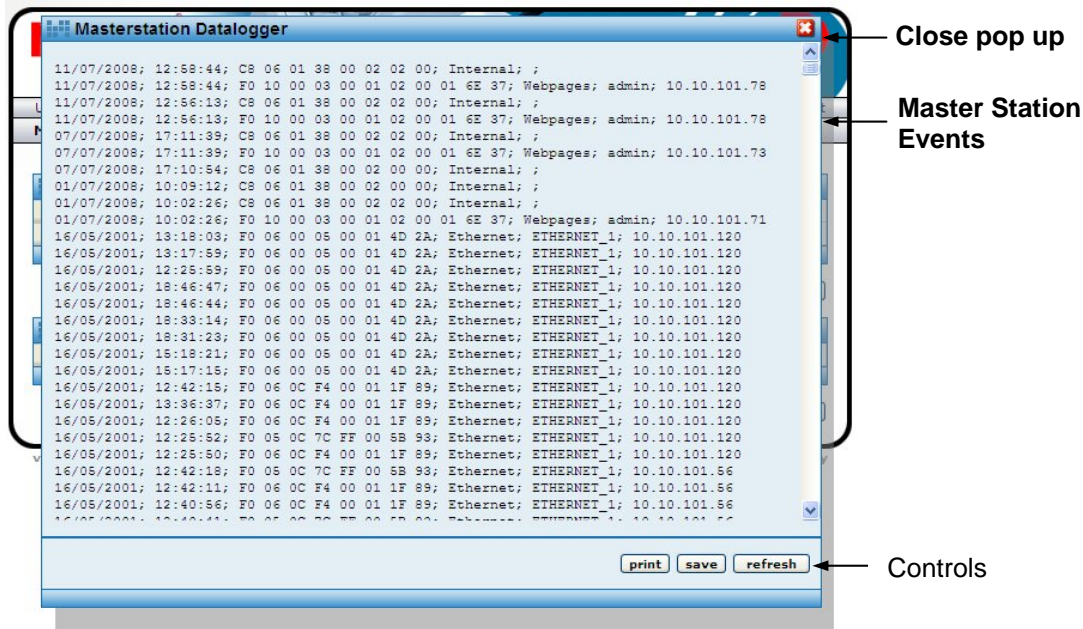

Fig 24: Master Station Data Logger

This screen is accessible to Read, Write and Administration user levels.

The data logger displays Modbus instructions received by the master station to carry out commands such as Alarm Accept or commands to move a valve. Each event is prefixed by a date and time and they are listed in time order. They are followed by the source from which the command originated. Once full the log rolls over and rewrites over the oldest events, the log is 1Mbyte in size.

Date and Time	Modbus Message	Message Source/Address
01/07/2008; 10:02:26;	C8 06 01 38 00 02 02 00; Internal; ;	
01/07/2008; 10:02:26;	F0 10 00 03 00 01 02 00 01 6E 37;	Webpages; admin; 10.10.101.71
16/05/2001; 13:18:03;	F0 06 00 05 00 01 4D 2A;	Ethernet; ETHERNET_1; 10.10.101.120

Fig 25: Data Logger Information

Date and Time

Formatted Day/Month/Year or Month/Day Year

Modbus Message

Standard Modbus RTU format for all 'write' messages

Message Source and Address

- Ethernet : Ethernet input and IP address of the source.
- RTU : Serial port 1 (RTU 1) or serial port 2 (RTU 2).
- Webpages : Webpage Log In name and IP address.

Controls - Available to all user levels

- Print** : Prints the logger to a printer attached to the PC.
- Save** : Saves the logger data to a file on the PC.
The saved file is of the type cmdlog.log and can be opened in the Notepad on the PC. It can also be imported into a spread sheet such as Excel for analysis as required.
- Refresh** : Updates the file with any new data.

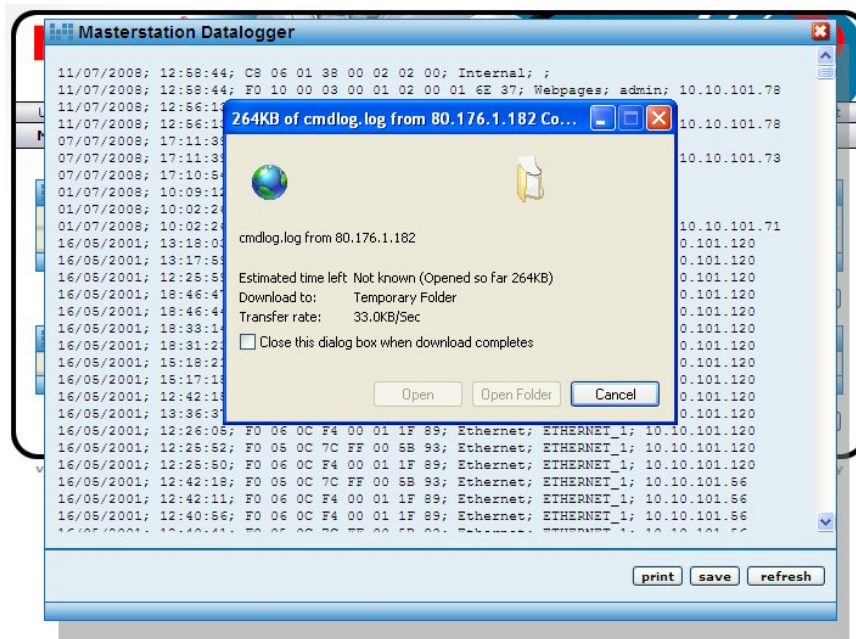

Fig 26: Saving the log file

5.5.6 Master Station Host Analyser

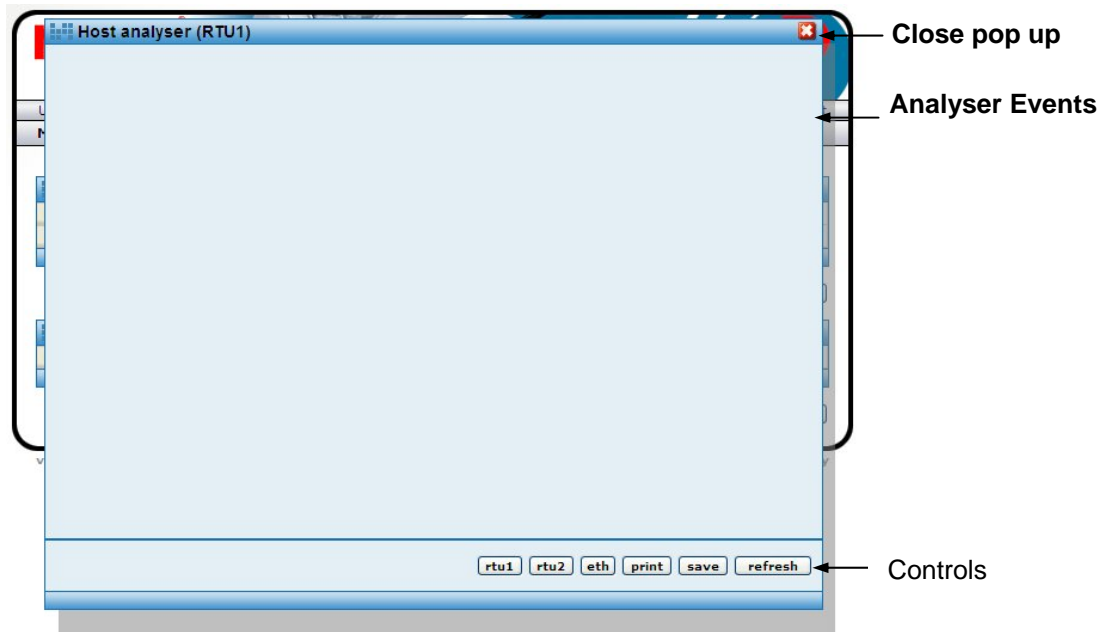

Fig 27: Host Analyser Screen

This screen may be used by Administration user level only.

The Host Analyser is a real time system analyser that can be used with either a Modbus RTU serial data control source acting through one of the serial data ports (Port 1 or 2), or a Modbus TCP Ethernet control source acting through the Ethernet port.

The analyser will record up to 100 messages (requests and responses) on the data line between the two points. It is especially useful for debugging a host control system to ensure that messages are correctly formatted and that the required control or data points are being accessed. In particular the use of correct offsets in the Modbus protocol can be checked.

Controls - Available to Administration user level

- RTU1 : Selects Port 1 host input.
- RTU2 : Selects Port 2 host input.
- ETH : Selects the Ethernet port host input.
- Print : Prints the analyser data to a printer attached to the PC.
- Save : Saves the analyser data to a file on the PC.
- Refresh : Updates the file with any new data.

5.5.7 Pakscan 2 Loop Diagnostics

rotork®
Pakscan

User: Guest Viewer, Read 19/08/2008 14:58 Logout

Masterstation View Configuration System Diagnostics FCU Menu

Network Diagnostics

No Of Devices On Network	10
No Of FCU's Found	10
Configuration Status	
Last Network Reset Initialised By	Reset occurred
Network Fault Type	No faults
Loop Baud Rate	1200
No Of FCU's On Side A	10
No Of FCU's On Side B	0

reset network

Network Map

Position	Address	Failures	Type	Tag Name
1	1	0	IQ	-
2	2	0	IQT	-
3	3	0	Integral	-
4	4	0	EH	-
5	5	0	Skilmatic	-
6	6	0	IQ	-
7	7	0	IQ	-
8	8	0	IQ Analogue	-
9	9	0	IQ	-
10	10	0	GPFCU - GP	-

← Network

← Controls

← Network FCU Map

Fig 28: Pakscan 2 Loop Diagnostics

This screen is accessible to Read, Write and Administration user levels.

The Pakscan 2 Loop Diagnostics screen gives diagnostic information on the two-wire loop option card and the network connected to it. The top part of the screen shows the information about the option card itself whilst the lower part shows the loop map. This is the order in which the field units on the two-wire loop are connected. It also shows the device type and tag name for each address and position.

Network Diagnostics

- No. Of Devices On Network : This is the number of field units that are expected to be located on the network. It is the highest address that the network will scan up to when locating field units. All field units are assumed to be consecutively addressed.
- No. Of FCUs Found : This is the total number of field units located on the network. If all the field units are powered on and connected the number will equal the No. of devices on the network above.
- Configuration Status : This field shows any fault that exists on the network cabling and the stages passed through as network configuration takes place.

During configuration the following sequence can be displayed -

1. Wait for Loopbacks 1 (first wait for loopbacks to come on)
2. Find FCUs on Port A (finding FCUs on port A)
3. Test Loop (testing for complete loop)
4. Find FCUs on Port B (finding FCUs on port B)
5. Wait for Loopbacks 2 (second wait for loopbacks to come on)
6. Loopbacks off on A (removing loopbacks from port A)
7. Loopbacks off on B (removing loopbacks from port B)

(The normal sequence for a fault-free loop would be 1, 2 and 3. A sequence for a break in the loop anywhere except at port A or port B, would be 1 to 7. Some of the phases may be very quick, particularly at higher baud rates, and so may not be seen on the browser display.

Whilst the configuration is taking place, the master station web page shows a blue light and 'Loopback in Progress' on the Option module.

If the configuration process detects a fault on the loop and switches on the loopback circuits of two field units, the master station web page shows 'Loopback in Use' and illuminates the yellow light.

- Last Network Reset Initialised By** : The loop can be reconfigured for a number of reasons and this field will show the cause of the last reset/reconfigure that occurred.
The possible reasons are:
- Power on Reset - loop configured because the master station powered up.
 - Fault Found - fault detected on the loop whilst it was running without loopbacks present.
 - Fault Found A - fault detected on the A side of broken loop whilst running with loopbacks on.
 - Fault Found B - fault detected on the B side of broken loop whilst running with loopbacks on.
 - Reset Command - loop Reconfigure command entered from keypad or serial port.
 - Return wire fault - fault detected in the return current path whilst the loop was running at double speed.
 - Doubling failed - fault detected after loop assumed double speed.
- Network Fault Type** : This field shows the type of fault detected that caused the loopback to occur, or an addressing fault on the field units. The types are:
- Zero Address - a field unit has been found with an address of zero.
 - Address too High xx - a field unit has been found with an address higher than that setup within the master station, xx is the address.
 - Same Address xx - two field units found with the same address, xx is the address
 - Loop Open Circuit - an open-circuit fault found on the loop.
 - Loop Short Circuit - a short-circuit fault found on the loop.

If two field units are found with the same address, or there is an address outside the range of addresses expected (as set by No. of Devices on

Network), the network will continue to operate and miss out the faulty field units.

Loop Baud Rate : Shows the current speed selected. The speed can be 110, 300, 600, 1200, or 2400 baud.

No. Of FCUs On Side A : This is the total number of field units connected to the option card Port A and communicating via Port A.

No. Of FCUs On Side B : This is the total number of field units connected to the option card Port B and communicating via Port B. Port B is only used if there is a loopback present on the network.

Controls - Available to all user levels

Reset network : Causes the option card to reconfigure the two-wire network. This should be used after a loop fault has been corrected.

Network Map

The map shows the order in which the field units have been identified and found by the option card during the last loop reconfiguration process (reset). Each time the loop is reconfigured the map is regenerated and repopulated. Any field unit that is not powered up at the time of reconfiguration will be absent from the map.

Position : The position in the loop. Number 1 is nearest to Port A.

Address : The address of the field unit.

Failures : Shows a count of communication errors with the field unit. The count has a range of 0 to 255, after which it rolls around to zero and it increments for every communication error. The system will only announce a 'Comms failure' when 3 successive tries have failed to locate the field unit. This counter therefore reflects the communications condition and can be used as an indicator of the health of the field unit to assess the probability of failure in the future.

Type : The type of field unit depends on the actuator and function required.

Tag Name : The associated identification Tag assigned to this field unit.

5.5.8 Option Card Event Logger

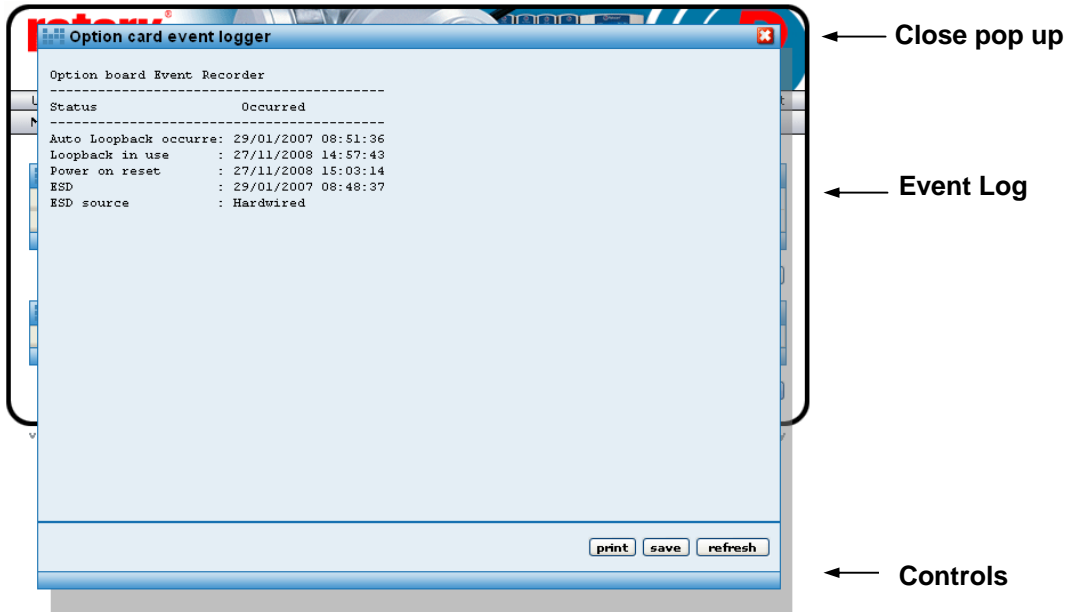

Fig 29: Option Card Event Logger

This screen is accessible to Read, Write and Administration user levels.

The event logger shows the last occurrence of the listed events and in the case of the ESD source, where the signal originated.

Controls - Available to all user levels

- Print** : Prints the logger to a printer attached to the PC.
- Save** : Saves the logger data to a file on the PC.
- Refresh** : Updates the file with any new data.

5.5.9 FCU Menu

Address	Tag Name	Type	Network	Alarm	Comms Fail	Navigation
1	-	IQ	Pakscan2	●	●	fcu control
2	-	IQT	Pakscan2	●	●	fcu control
3	-	Integral	Pakscan2	●	●	fcu control
4	-	EH	Pakscan2	●	●	fcu control
5	-	Skilmatic	Pakscan2	●	●	fcu control
6	-	IQ	Pakscan2	●	●	fcu control
7	-	IQ	Pakscan2	●	●	fcu control
8	-	IQ Analogue	Pakscan2	●	●	fcu control
9	-	IQ	Pakscan2	●	●	fcu control
10	-	GPFCU - GP	Pakscan2	●	●	fcu control

Fig 30: FCU Menu

This screen is accessible to Read, Write and Administration user levels.

The FCU Menu lists all the field units in address order (which may not be the same as the order in which they connected together on the loop).

For each address, the Tag name and Type of field unit is listed. The Network column shows which option card network each actuator is connected to, this will be Pakscan 2 for the two-wire loop option card.

The next two columns show critical alarm conditions that will prevent remote control of the actuator. An Alarm present will generally prevent operation whilst Comms Fail indicates that the actuator is no longer in communication with the network.

The final column has Navigation controls to the individual FCU screens.

Controls - Available to all user levels

FCU Control : Click here to show the selected FCU individual control panel web page. The different types of devices each have different screens and only the relevant data and controls for each type are included on the screen, together with a picture identifying the type. When not in communication, the screen may still be visited, but the actuator picture will have a large red cross over it to show that a problem exists.

5.5.10 FCU Control - IQ/IQT Actuator

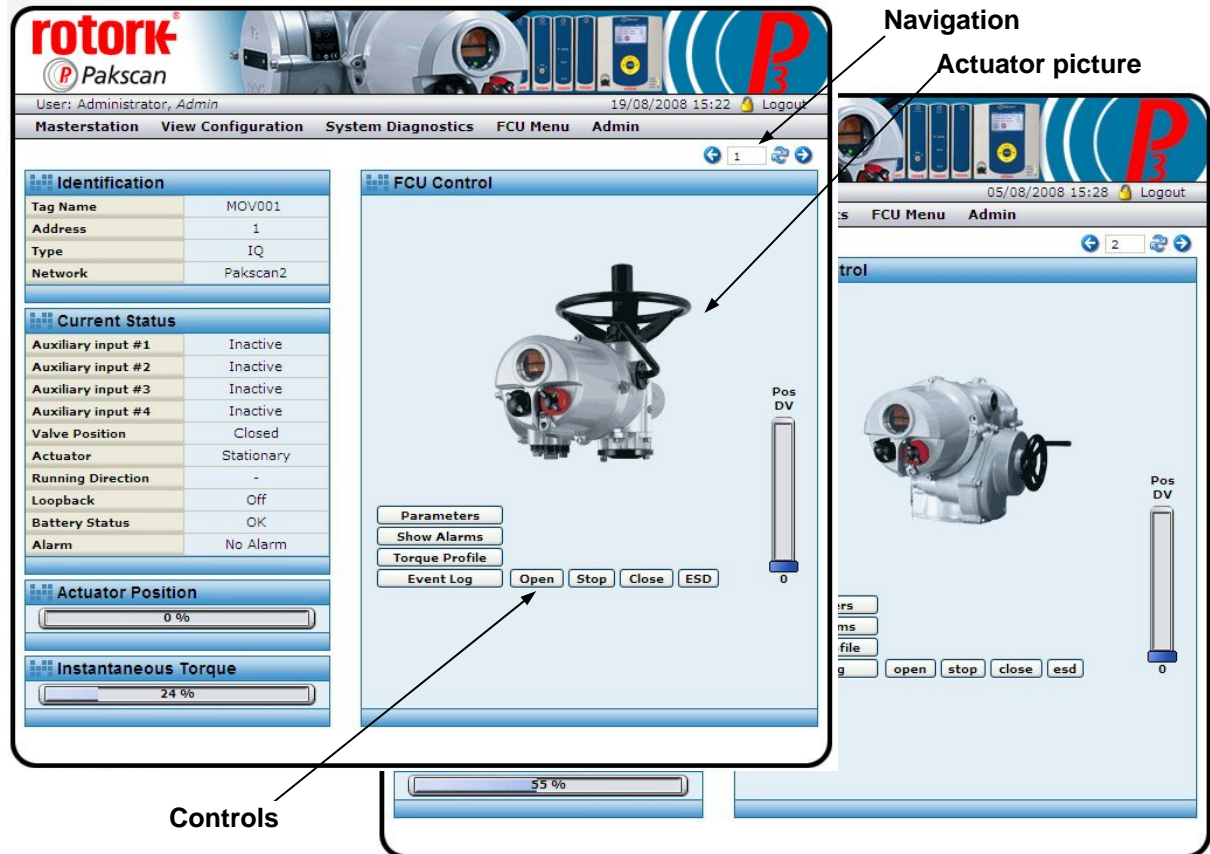

Fig 31: IQ and IQT actuator FCU Control

This screen is accessible to Read, Write and Administration user levels.

The IQ and IQT control screens are similar and show a picture to identify the actual type of actuator at this FCU address.

The FCU Control screen shows a control and status page for the selected field unit and actuator. The screen has information relating to the device, its current condition and system parameters. It also includes the ability to change the actuator's position by means of the control buttons. When not in communication the screen may still be visited, but the picture has a large red cross over it to show a lack of communications.

Navigation

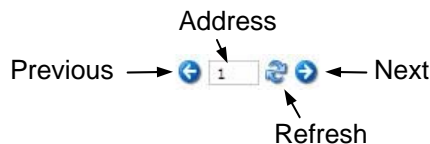

Navigation between the field units is either by returning to the previous screen, or by using the navigation buttons on this screen. Entering an address directly in the 'Address' box and clicking Refresh moves directly to the selected field unit.

Identification

Tag name	: Identification tag given for this device.
Address	: Network address.
Type	: Shows the identified actuator type as IQ (IQT on the IQT screen).
Network	: The network to which this device is connected (Pakscan 2 for two-wire loop).

Current Status

The real time status of the actuator is listed in this pane on the screen.

Auxiliary Input 1 to 4	: Active or Inactive shows the status of the actuator Digital inputs.
Valve Position	: Current position, closed, open or stopped mid position.
Actuator	: Moving or stationary.
Running Direction	: Opening or closing.
Loopback	: Off or On.
Battery Status	: OK or Low.
Alarm Status	: No Alarm or Alarm.

Actuator Position

A bar graph shows the current actuator analogue position between 0 (closed) and 100% (open).

Instantaneous Torque

A bar graph shows the current torque value between 0 and 120%.

Controls**Parameters - Viewable by all user levels**

Fig 32: IQ Parameters (IQT Parameters similar)

Pop-up screen shows the settings for all the parameters relating to the IQ actuator field unit. For users with Administration level rights the values can be edited and for the latest version field units, the type of actuator can be modified. The parameters are used to determine the way in which the actuator responds to commands and reports data. Information on how to set these fields is contained in the actuator field unit manuals.

Controls

Save Settings : Edited fields may be saved, accessible by **Administrator** level users only

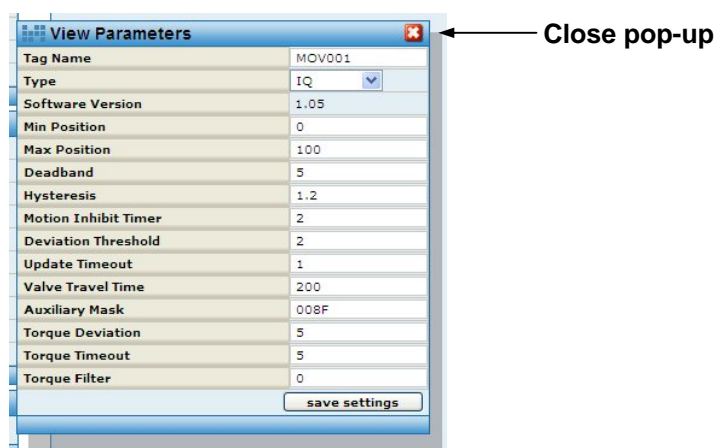
Show Alarms - Viewable by all user levels

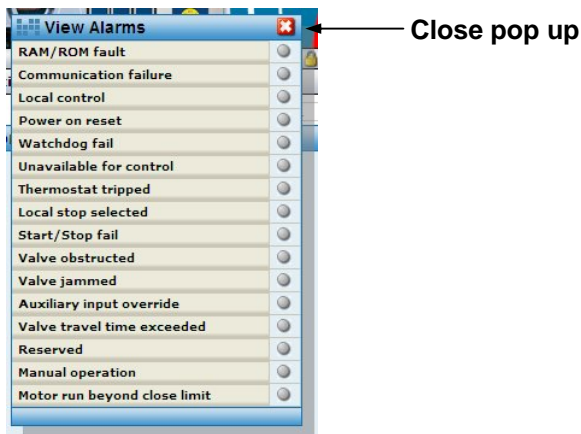

Fig 33: IQ Alarms (IQT Alarms similar)

Pop-up screen shows the alarms on the actuator as red lights, grey is no alarm. Additional information on the meaning of these alarms is contained in the individual field unit manuals.

Torque Profile - Viewable by all user levels

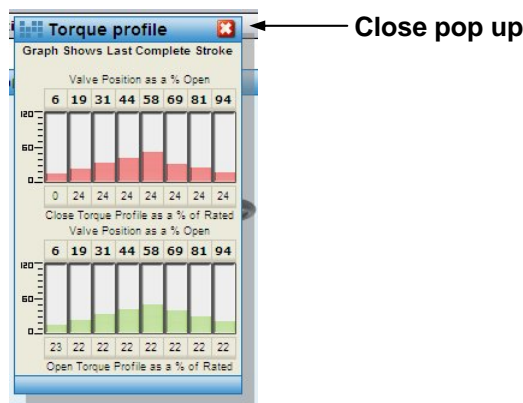

Fig 34: IQ Torque Profile (IQT Torque Profile similar)

Pop-up screen shows the last complete stroke torque profile generated by the actuator.

Event Log - Available to all user levels

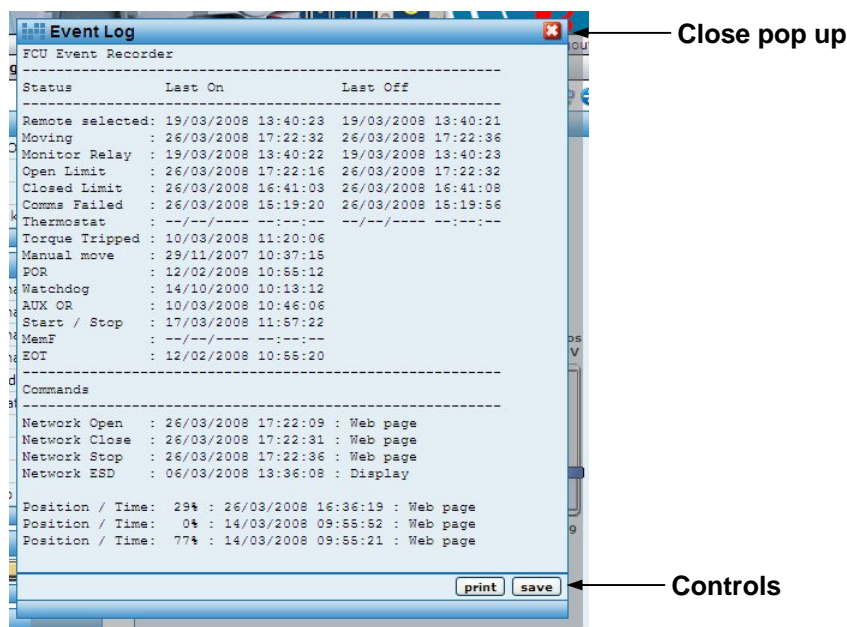

Fig 35: IQ FCU Event Log (IQT Event Log similar)

Pop-up screen showing a log of the last occasion on which the various control and alarm events occurred. For commands, the source of the command is also given.

Remote selected	- local remote selector in remote position.
Moving	- actuator centre column moving.
Monitor Relay	- monitor relay alarm.
Open Limit	- open position limit switch.
Closed Limit	- closed position limit switch.
Comms Failed	- loss of network communication.
Thermostat	- motor thermostat tripped.
Torque Tripped	- torque limit level exceeded.
Manual move	- actuator moved by the handwheel.
POR	- power on reset.
Watchdog	- Field unit watchdog alarm.
AUX OR	- Auxiliary input present.
Start / Stop	- Failure to respond to a remote control input.
MemF	- FCU memory chip RAM or ROM fault.
EOT	- Motor running at end of travel.

Network Open	- open instruction over the control network.
Network Close	- close instruction over the control network.
Network Stop	- stop instruction over the control network.
Network ESD	- ESD instruction over the control network.
Position / Time	- last position control event.
Position / Time	- last-but-one position control event.
Position / Time	- last-but-two position control event.

Controls

- Print : Prints the datalogger to a printer available to the PC.
- Save : Saves the logger data to a file on the PC.

Actuator Controls - Available to Write and Administration user levels only

- Open : command to open the valve fully.
- Stop : command to stop the actuator in its present position.
- Close : command to close the valve fully.
- ESD : command to put the valve in its Emergency Shut Down position. (This can be 'stayput' or move to either the open or closed position).
- Pos DV : a slider control that is used to generate a setpoint position for the valve in the range 0 - 100%.

All the controls have a confirmation pop-up so that the action has to be confirmed before it takes place.

5.5.11 FCU Control - Integral Actuator

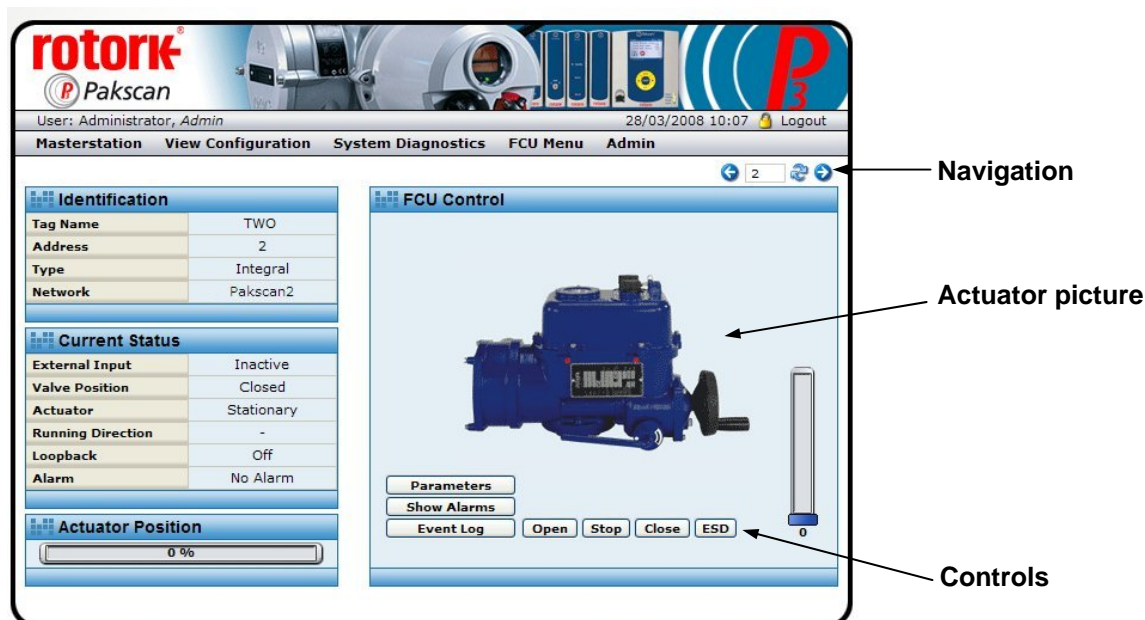
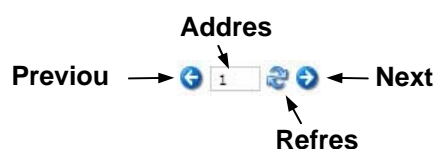

Fig 36: Q actuator FCU Control

This screen is accessible to Read, Write and Administration user levels.

The Integral actuator FCU Control screen shows a control and status page for a Q type actuator. The screen has information relating to the device, its current condition and system parameters. Control of the actuator is permitted via the control buttons for users with write level access or higher. When not in communication, the screen may still be visited, but the picture has a large red cross over it to show a lack of communications.

Navigation



Navigation between the field units is either by returning to the previous screen, or by using the navigation buttons on this screen. Entering an address directly in the 'Address' box and clicking Refresh moves directly to the selected field unit.

Identification

Tag name : Identification tag given for this device.
 Address : Network address.
 Type : Shows the identified actuator type as Q.
 Network : The network to which this device is connected (Pakscan 2 for two wire loop).

Current Status

The real time status of the actuator is listed in this pane on the screen.

- External Input : Active or Inactive shows the status of the input.
- Valve Position : Current position, closed, open or stopped mid position.
- Actuator : Moving or stationary.
- Running Direction : Opening or closing.
- Loopback : Off or On.
- Alarm Status : No Alarm or Alarm.

Actuator Position

For actuators fitted with position feedback facilities, a bar graph shows the current actuator analogue position between 0 (closed) and 100% (open).

Controls

Parameters - Viewable by all user levels

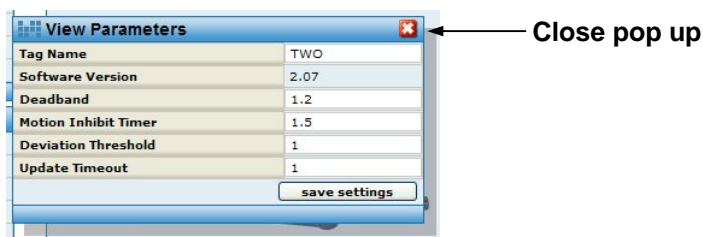

Fig 37: Q Parameters

Pop-up screen shows the settings for all the parameters relating to the integral field unit. For users with Administration level rights the values can be edited.

Controls

- Save Settings : Edited fields may be saved, accessible by **Administrator** level users only.

Show Alarms - Viewable by all user levels

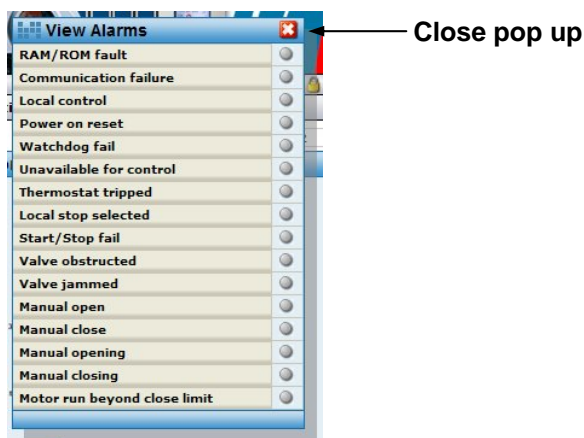

Fig 38: Q Alarms

Pop-up screen shows the alarms on the actuator as red lights, grey is no alarm. Additional information on the meaning of these alarms is contained in the individual field unit manuals.

Event Log - Available to all user levels

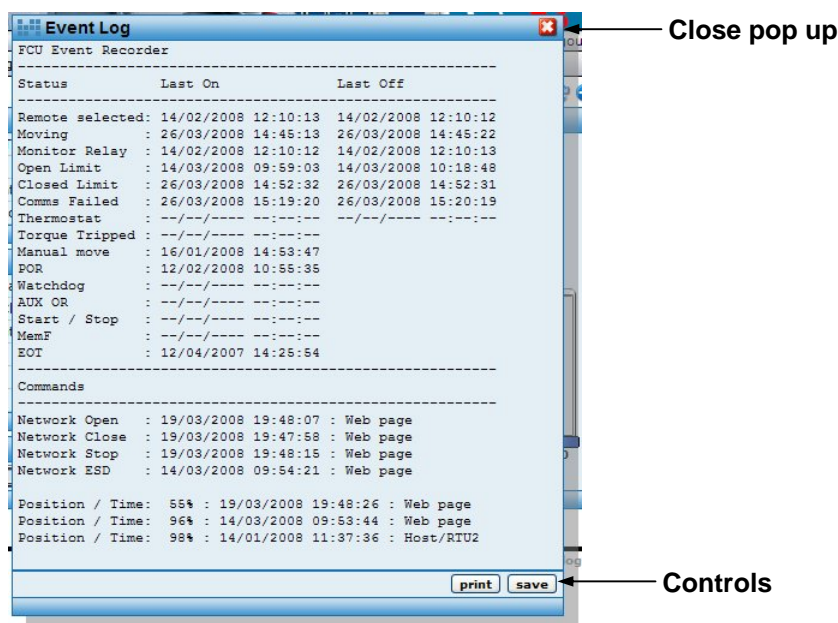

Fig 39: Q FCU Event Log

Pop-up screen showing a log of the last occasion on which the various control and alarm events occurred. For commands, the source of the command is also given.

Remote selected	- local remote selector in remote position.
Moving	- actuator centre column moving.
Monitor Relay	- monitor relay alarm.
Open Limit	- open position limit switch.
Closed Limit	- closed position limit switch.
Comms Failed	- loss of network communication.
Thermostat	- motor thermostat tripped.
Torque Tripped	- torque limit level exceeded.
Manual move	- actuator moved by the handwheel.
POR	- power on reset.
Watchdog	- Field unit watchdog alarm.
AUX OR	- Auxiliary input present.
Start / Stop	- Failure to respond to a remote control input.
MemF	- FCU memory chip fault.
EOT	- Motor running at end of travel.
Network Open	- open instruction over the control network.
Network Close	- close instruction over the control network.
Network Stop	- stop instruction over the control network.

Network ESD - ESD instruction over the control network.
Position / Time - last position control event.
Position / Time - last but one position control event.
Position / Time - last but two position control event.

Controls

Print : Prints the datalogger to a printer attached to the PC.
Save : Saves the logger data to a file on the PC.

Actuator Controls - Available to Write and Administration user levels only

Open : command to open the valve fully.
Stop : command to stop the actuator in its present position.
Close : command to close the valve fully.
ESD : command to put the valve in its Emergency Shut Down position. (This can be 'stayput' or move to either the open or closed position).
Pos DV : a slider control that is used to generate a setpoint position for the valve in the range 0 - 100%. Only available for actuators fitted with position feedback facilities

All the controls have a confirmation pop-up so that the action has to be confirmed before it takes place.

5.5.12 FCU Control - Flowpak Actuator

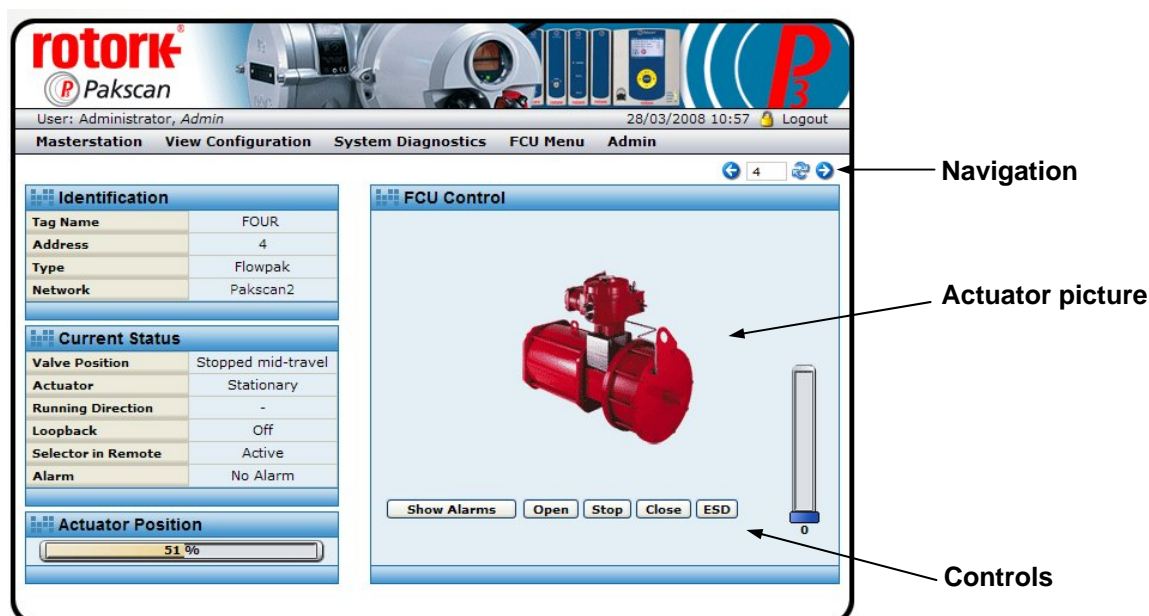
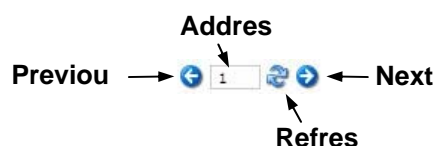

Fig 40: Flowpak actuator FCU Control

This screen is accessible to Read, Write and Administration user levels.

The Flowpak actuator FCU Control screen shows a control and status page for a Flowpak type actuator. The screen has information relating to the device, its current condition and system parameters. Control of the actuator is permitted via the control buttons for users with write level access or higher. When not in communication the screen may still be visited, but the picture has a large red cross over it to show a lack of communications.

Navigation



Navigation between the field units is either by returning to the previous screen, or by using the navigation buttons on this screen. Entering an address directly in the 'Address' box and clicking Refresh moves directly to the selected field unit.

Identification

Tag name : Identification tag given for this device.
 Address : Network address.
 Type : Shows the identified actuator type as Flowpak.
 Network : The network to which this device is connected (Pakscan 2 for two wire loop).

Current Status

The real time status of the actuator is listed in this pane on the screen.

- Valve Position : Current position, closed, open or stopped mid position.
- Actuator : Moving or stationary.
- Running Direction : Opening or closing.
- Loopback : Off or On.
- Selector in Remote: Active when available for remote control.
- Alarm Status : No Alarm or Alarm.

Actuator Position

For actuators fitted with position feedback facilities, a bar graph shows the current actuator analogue position between 0 (closed) and 100% (open).

Controls

Show Alarms - Viewable by all user levels

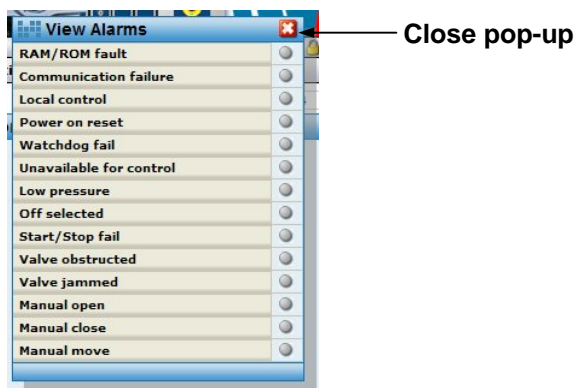

Fig 41: Flowpak Alarms

Pop-up screen shows the alarms on the actuator as red lights, grey is no alarm.

Actuator Controls - Available to Write and Administration user levels only

- Open : command to open the valve fully.
- Stop : command to stop the actuator in its present position.
- Close : command to close the valve fully.
- ESD : command to put the valve in its Emergency Shut Down position. (This can be 'stayput' or move to either the open or closed position).
- Pos DV : a slider control that is used to generate a setpoint position for the valve in the range 0 - 100%.

All the controls have a confirmation pop-up so that the action has to be confirmed before it takes place.

5.5.13 FCU Control - General Purpose Field Unit

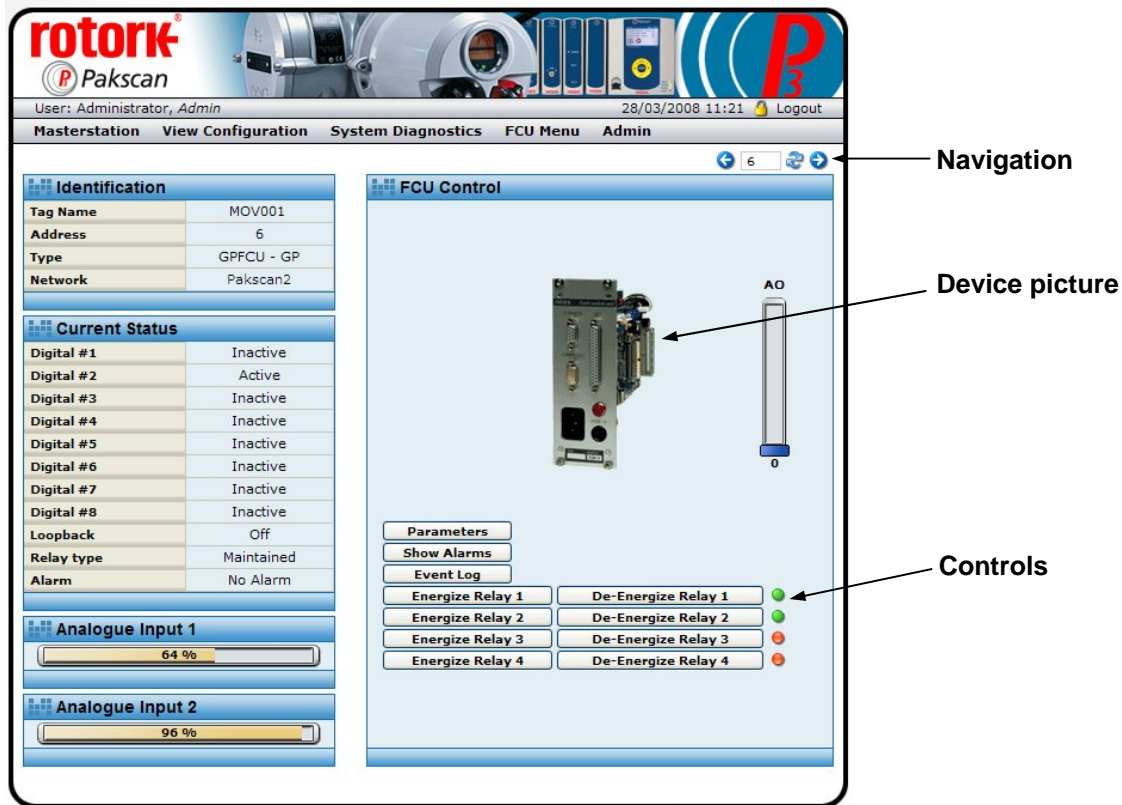
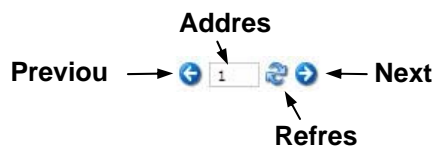

Fig 42: GP FCU Control

This screen is accessible to Read, Write and Administration user levels.

The GP FCU Control screen shows a control and status page for a general purpose field unit. The screen has information relating to the device, its current condition and system parameters. Control of the outputs is permitted via the control buttons for users with write level access or higher. When not in communication the screen may still be visited, but the picture has a large red cross over it to show a lack of communications.

Navigation



Navigation between the field units is either by returning to the previous screen, or by using the navigation buttons on this screen. Entering an address directly in the 'Address' box and clicking Refresh moves directly to the selected field unit.

Identification

Tag name : Identification tag given for this device.

- Address : Network address.
- Type : Shows the identified device type as GPFCU-GP.
- Network : The network to which this device is connected (Pakscan 2 for two wire loop).

Current Status

The real time status of the actuator is listed in this pane on the screen.

- Digital # 1 to # 8 : Digital input signal status, active or Inactive.
- Loopback : Off or On.
- Relay Type : Fleeting or Maintained outputs from the relays.
- Alarm Status : No Alarm or Alarm.

Analogue Input 1 and 2

For the two analogue input channels, a bar graph shows the current actuator analogue position between 0 and 100%.

Controls

Parameters - Viewable by all user levels

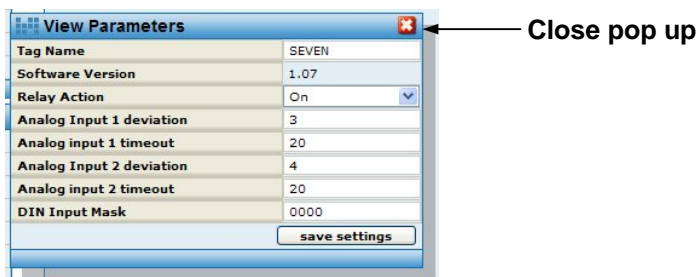

Fig 43: GP FCU Parameters

Pop-up screen shows the settings for all the parameters relating to the general purpose field unit. For users with Administration level rights the values can be edited.

Controls

- Save Settings : Edited fields may be saved, accessible by **Administrator** level users only

Show Alarms - Viewable by all user levels



Fig 44: GP FCU Alarms

Pop-up screen shows the alarms on the actuator as red lights, grey is no alarm.

Event Log - Available to all user levels

Fig 45: GP FCU Event Log

Pop-up screen showing a log of the last occasion on which the various alarms, input and output events occurred. For commands the source of the command is also given.

Comms Failed - loss of communication with the field unit.
 POR - power on reset.
 Digital Input 1-8 - when turned on and off.
 Analogue I/P 1 -2 - when last updated.
 Digital Output 1-4 - when energised and de-energised.
 Analogue Output - when last altered and by which source.

Controls

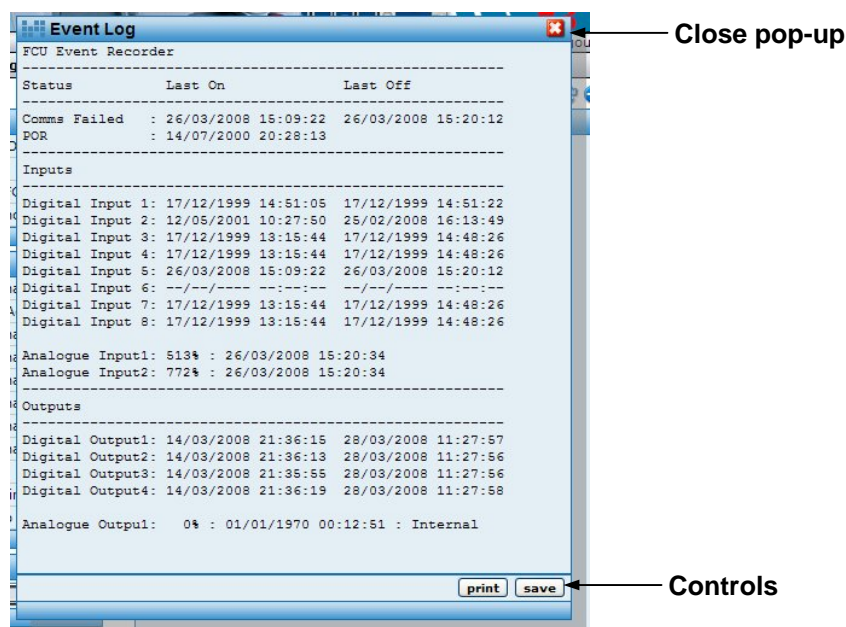
Print : Prints the datalogger to a printer attached to the PC.
 Save : Saves the datalogger data to a file on the PC.

FCU Controls - Available to Write and Administration user levels only

Energise Relay 1-4 : commands to energise the relays (green light when energised).
 De-energise Relay 1-4 : command to de-energise the relays (red light when de-energised).

Pos DV : a slider control that is used to generate a setpoint position for the valve in the range 0 - 100%.

All the controls have a confirmation pop-up so that the action has to be confirmed before it takes place.

5.5.14 FCU Control - Other Field Units

In addition to the field units described above there are other types that can be connected to the Pakscan network. The controls and displays available are all similar to those used on the FCU already explained.

IQ Analogue

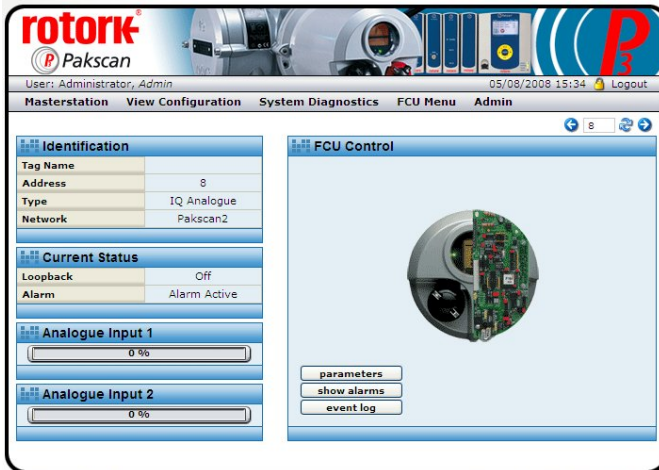

Fig 46: IQ Analogue FCU Control

The IQ Analogue FCU allows two standard instrumentation analogue signals to be transmitted from the field to the master station.

Skilmatic

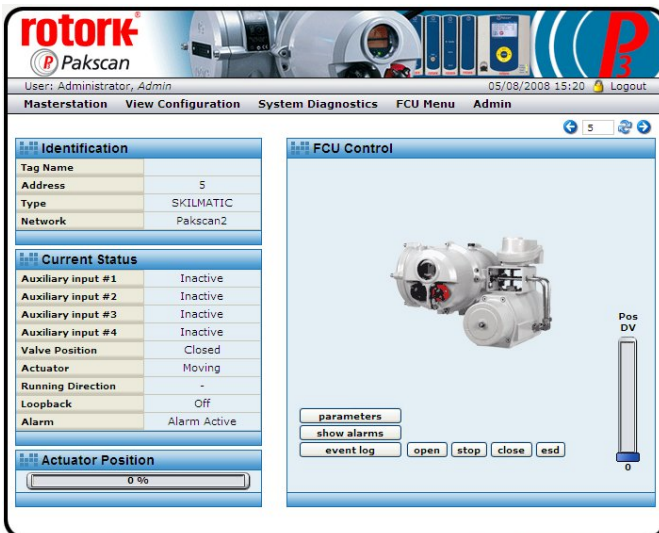

Fig 47: Skilmatic Actuator FCU Control

The Skilmatic electro-hydraulic actuator is fitted with a field unit similar to a standard IQ actuator. The controls available include the alarms and event log.

EH Electro Hydraulic



Fig 48: EH Actuator FCU Control

The EH electro-hydraulic actuator is also fitted with a field unit similar to a standard IQ actuator. The controls available include the event log and ability to set the parameters of the field unit.

5.5.15 Admin

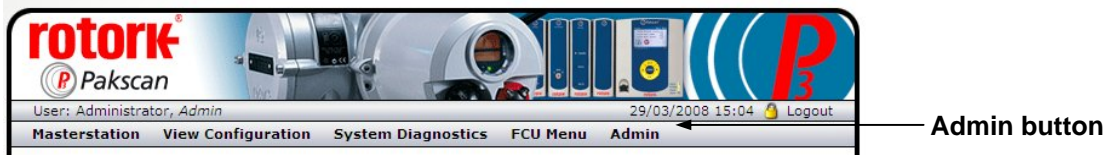

Fig 49: Administration Level

This screen is only accessible to Administration user levels.

When logged in at Administrator level the top of the screen menu list includes the Admin button. Clicking on this button gives entry to the Administrator level screens.

5.5.16 Users

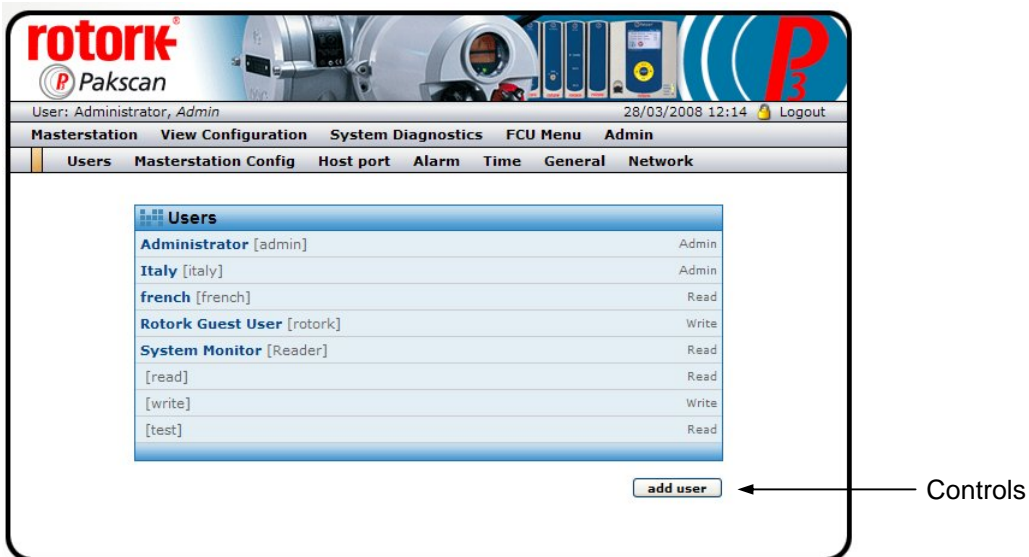

Fig 50: Users

This screen is only accessible to Administration user levels.

The 'Users' screen shows all the users currently entered into the system. The actual user at any time is shown on the top left of the menu bar, in the example above the user name is 'Administrator' and the log in level is 'admin'.

Each user has a Name, a User ID, a User Level and a Password. When logging into the system, to gain entry, the User ID and Password are required. The screen shows the Name, User ID and User Level, the password is not shown and cannot be revealed on any of the screens.

Every system includes a default User ID of Admin and Password of Admin on delivery in order that the system can be set up and commissioned. This password and user ID should be removed and replaced by a unique Administrator as soon as possible to protect the system against unauthorised access.

Name	Name of the current user, displayed on the top bar.
User ID	Secret identification used to gain entry to the system, shown in user list.
Password	Secret code of letters (and numbers) used to gain entry to the system. Not shown on the system.
User Level	Indication of access level permitted for this user, shown on the top bar.

Controls - Available to Administrators only

- Add user : Click this button to bring up the screen to add a user
- Username : Click on a user name (e.g. Administrator) to bring up the Modify User screen for editing user details.

The screenshot shows the 'Add User' form within a web browser interface. The form includes the following fields and controls:

- User ID: Text input field
- Name: Text input field
- E-mail: Text input field
- Mobile: Text input field
- Alarm User: Radio buttons for 'Yes' and 'No' (with 'No' selected)
- Language: Dropdown menu
- User Level: Dropdown menu (with 'Read' selected)
- Password: Text input field
- Repeat Password: Text input field
- Navigation buttons: 'back', 'save settings', and 'remove'

An arrow labeled 'Controls' points to the 'back', 'save settings', and 'remove' buttons at the bottom of the form.

Fig 51: Add User

The Add User screen contains the fields to be completed for each permitted user either by completing the data box, selecting from a drop down or selecting a radio button.

- User ID : Enter a unique name to use when logging in to the system.
- Name : Enter a name to be used in all emails and on the system logs.
Several users can have the same name, but this is not recommended.
- E-mail : If E-mail messages concerning the system alarms are to be sent to this user, enter a valid E-mail address.
- Mobile : If text messages are to be sent to a mobile phone associated with this user, enter the complete phone number here.

- Alarm User : Select 'Yes' or 'No' for the choice of sending E-mails and Text messages to this user.
- Language : Select the language to be used on the screens. Choices are English, French, German, Spanish, and Italian.
- User Level : Select between Read, Write and Admin levels.
- Password : Enter a unique password of letters and/or numbers kept secret by this user.
- Repeat Password : Enter the same password as above.
- Back : Exit the screen without saving anything and return to the previous screen.
- Save Settings : Save the details of this user (either new or edited values).

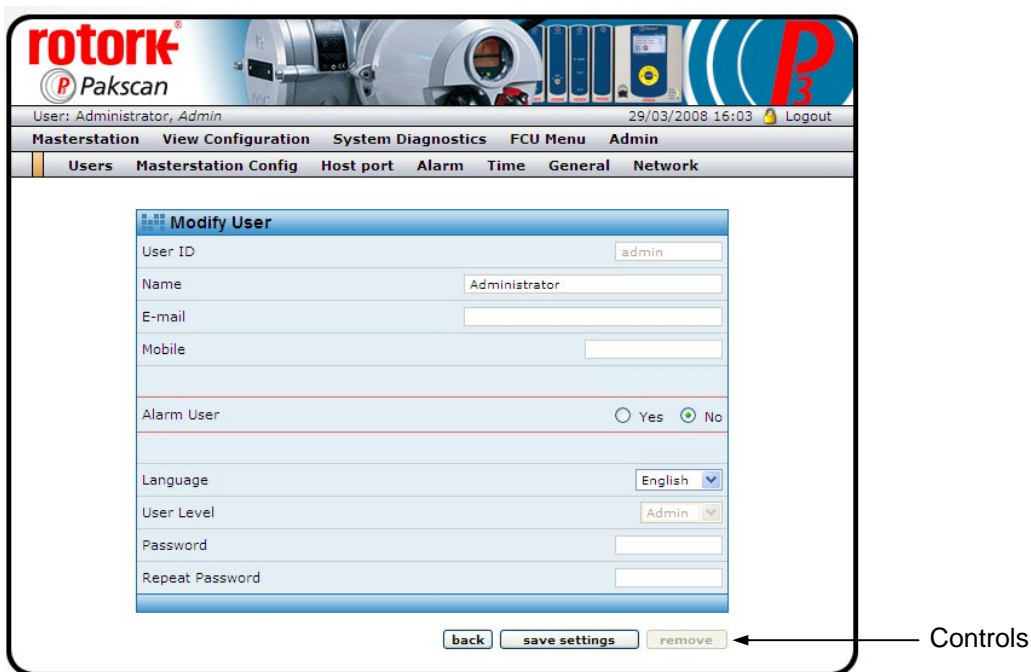

Fig 52: Modify User

The Modify User screen allows user details to be altered or a user to be removed. A User cannot delete himself from the system, only those with less access rights, so here in the example the User ID of 'admin' is greyed out since this is the actual user.

- Remove : Delete this entry on the system.

5.5.17 Masterstation Config

The screenshot displays the 'Masterstation Configuration' web interface. At the top, the user is identified as 'Administrator, Admin' and the date/time is '30/04/2009 15:21'. The navigation menu includes 'Masterstation', 'View Configuration', 'System Diagnostics', 'FCU Menu', and 'Admin'. The 'Masterstation Config' menu item is highlighted. The main configuration area is divided into two sections. The first section, 'Masterstation Configuration', includes fields for 'Site name' (ROTORK LAB), 'Tag name' (P3F-1), and 'Option 1 Modbus address' (240). It also features several 'Enabled' dropdown menus for 'Ethernet ESD', 'Webpage ESD', 'Hardwired ESD', 'Serial ESD', 'Ethernet', 'Webpage', 'Serial Port 1', and 'Serial Port 2'. The 'Number of channels' is set to 32, and the 'Software version' is 2.01.01. Below this section are 'print page' and 'save settings' buttons. The second section, 'Option 1: Pakscan 2 Loop', includes fields for 'Software version Option 1' (1.1.1), 'Highest FCU address' (10), 'Loop speed' (1200), 'New loop speed' (N/A), 'Loop speed doubling' (OFF), 'Retain data on loss of communications' (OFF), 'DV convert' (OFF), 'Host Port 1 Database Selection' (Generic Modbus), 'Host Port 2 Database Selection' (Generic Modbus), 'Ethernet Database Selection' (Generic Modbus), and 'Port alarms' (Separate). A 'save settings' button is located at the bottom of this section. Arrows from external labels point to the navigation menu, the ESD settings dropdowns, the 'save settings' buttons, and the 'Option 1: Pakscan 2 Loop' header.

Fig 53: Master Station Configuration

This screen is only accessible to Administration user levels.

of the system and the parameters for the option cards fitted. In addition, it may be used to enter the site name and tag name of the system and various security settings. The values set in these parameters can be viewed under the 'View Configuration' button, but they may only be altered by users logged in at Administrator level.

The Masterstation settings relate to the overall performance of the system and common features and actions, irrespective of the option card fitted. Where these settings are relevant, they apply to all the option cards in the master station.

The Option card settings relate to the option card fitted in the option 1 slot. The Pakscan 2 Loop option card may only be fitted in this slot and must not be fitted in slot 2. It controls the actuators and field units over a two wire cable wired in a ring or loop, visiting each actuator in turn. The data signal is a modulated 20 mA current and the system includes automatic cable failure protection.

Masterstation Configuration

- Site Name : A text field in which a description of the site can be entered for identification purposes.
- Tag Name : A text field in which a tag identifier for this particular master station on the site can be entered.
- Option 1 Modbus Address : A numeric field for the address number. This is the address used to access the Pakscan 2 option card and master station. The default value is 240 and it is recommended that this is changed to avoid conflict with any new system added.
- ESD Settings : These four drop down boxes can each be set to 'Enable' or 'Disable' the related Emergency Shut Down signal, depending on the particular site requirements. In general the settings should be 'Disabled' unless the particular Emergency Shut Down function is required. The action for each individual actuator has to be set locally on the actuator to either close, open or stay put (no movement on receipt of the ESD signal) as required for each valve; refer to individual actuator manuals.
- Command Settings : These four drop-down boxes can each be set to 'Enable' or 'Disable' the host system commands to the actuators and field units from the indicated source of the signal. For example, commands over the Ethernet connection can be disabled, whilst those from Serial Port 1 can be enabled. Ethernet commands are those sent via the Ethernet ports from the host system using Modbus TCP. The Webpage is the system currently being used to set up the system. Commands on the individual field unit pages can be disabled by this setting. Serial Port 1 and Serial Port 2 are the RS232/RS485 Modbus RTU ports, which are commonly used for control and monitoring.
- Number of Channels : This value is fixed at 32 and indicates the maximum number of actuators or field units that can be connected to this system.
- Software Version : The version of software fitted to the CPU module.

Controls

- Print Page : Prints the settings to a printer attached to the PC.
- Save Settings : Saves the settings to the master station CPU module. Until they are saved any alterations to the settings will not take effect.

Pakscan 2 Loop Option

- Software Version : The version of software fitted to the Pakscan 2 Loop option module.
- Highest FCU : This text box contains the setting for the highest address used for an actuator (or field unit) on the two wire loop. The Pakscan 2 Loop card polls all field units up to this highest address. The loop scan time is minimised by restricting the polling to only those field units that should be present and

- scanning up to the highest address. All the addresses in the selected range should be used and gaps in the address range should be avoided. Gaps or unused addresses cause the system to run more slowly as the unused addresses are still checked. In addition, unused addresses will generate a communication failure alarm.
- Loop Speed** : This shows the current loop scanning speed (loop baud rate) and the drop-down box allows a desired loop speed to be selected. The choices are 2400, 1200, 600, 300 and 110 baud. When a new speed is entered it will take effect as soon as the values are saved. The setting applies to the Pakscan 2 Loop option card only and the actuators must be changed individually.
- New Loop Speed** : The drop down box allows a new data rate speed to be selected for the field units in the actuators. The new speed will be adopted next time the loop is reconfigured. A change here should be mirrored by a change in the loop speed setting above. It is possible to select rates in the range one step up or two steps down from the current speed.
If the loop communication is not stable it is often necessary to reduce the speed to improve reliability. If the field units are all in communication with the master station this is possible with this feature.
- Loop Speed Doubling** : On a stable loop it is possible to halve the loop scan time by doubling the data speed using this setting. Care is needed to ensure that the loop continues to be stable, since the use of this feature slightly reduces the system's capability to reject interference from pumps and motors.
- Retain Data on Loss of Communication** : Normally the data base information about an actuator is cleared to zeros if communication with the actuator is lost. This ensures that the false valve position information is not transmitted to the host system during the loss of communication. A single 'Comms Fail' data bit is set. This system setting allows the data to be kept at the last value received from the actuator. Note that the data is retained indefinitely and does not necessarily reflect the true actuator status.
- DV Convert** : This option can be used to ensure that 100% and 0% Desired Value outputs to the IQ, IQT, Skil and EH actuators are transformed into actions to make the actuator run to the fully open (100%) and fully closed (0%) positions. The message is converted from a DV command to an Open or Close command respectively. This is useful for positioning actuators, where it is possible that the valve will not fully shut or open when moved by only a small amount. When used for tight shut off valves, with analogue position control only, the setting should be ON; the default is OFF.
- Host Port 1 2, Ethernet Database Selection** : The drop-down box allows the data base organisation used on this port to be selected. The choices are Generic Modbus, Honeywell PLCG Modbus, Yokogawa Modbus and Honeywell SI Modbus.
- Port Alarms** : This drop-down box allows port alarm handling to be configured. Alarms can either operate completely independently ('separate') for each port, or can be linked such that the same alarm information is always reported, regardless of which port is used.
Alarms must be read and accepted before they can clear and return to normal. If configured as separate, alarm reading and acceptance must be done separately for each of the three ports. This ensures that the different

hosts see all the alarms. When the alarms are linked, accepting an alarm on one port accepts the alarm on all the other ports as well. Linking the port alarm operations is useful in dual redundant serial link configurations between the master station and the host computer

Controls

Save Settings : Saves the settings to the Pakscan 2 Loop option module. Until they are saved, any alterations to the settings will not take effect.

To print out the settings use the Print Page button below the Master station Configuration section of the screen.

5.5.18 Host Port Configuration

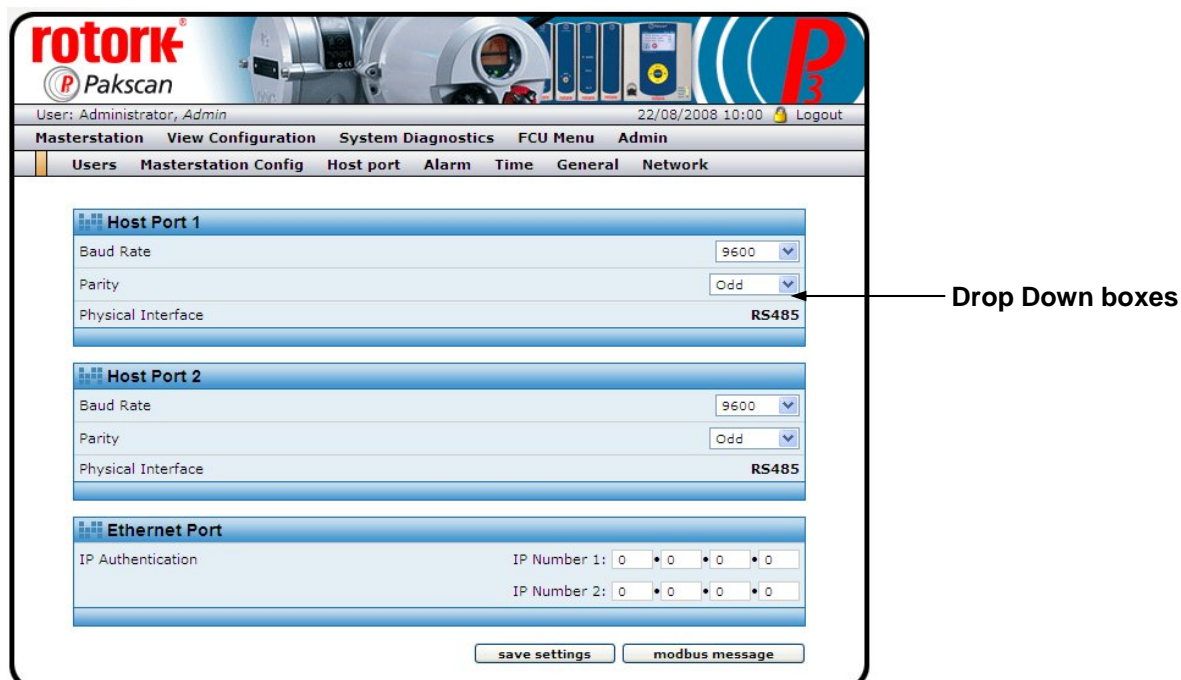

Fig 54: Host Port Configuration

This screen is only accessible to Administration user levels.

The host port configuration page allows the settings for the serial and Ethernet ports to be made. The two serial ports (ports 1 and 2) are independent from one another, whilst the Ethernet ports (ports 3 and 4) are linked together.

Host Port 1

- Baud Rate** : This drop-down box allows the communication speed (baud rate) for the serial port to be selected. The choices are 115200, 57600, 38400, 19200, 9600, 4800 or 2400 baud.
- Parity** : This box sets the message parity used by this port. The choices are None, Always 0, Odd or Even parity.
- Physical Interface** : Either RS232 or RS485 showing the switch setting for the physical interface from the CPU module (read only).

Host Port 2

- Baud Rate** : This drop-down box allows the communication speed (baud rate) for the serial port to be selected. The choices are 115200, 57600, 38400, 19200, 9600, 4800 or 2400 baud.
- Parity** : This box sets the message parity used by this port. The choices are None, Always 0, Odd or Even parity.
- Physical Interface** : Either RS232 or RS485 showing the switch setting for the physical interface from the CPU module (read only).

Ethernet Port

IP Authentication : The two IP addresses that can be set here relate to system access permission. When controlling the system via Ethernet and Modbus TCP, it is possible to increase the system security and only permit access from specified IP locations. If both the values set here are 0.0.0.0 then any IP address can access the system. When a specific IP address is entered in either IP Number 1 or IP Number 2, the system only allows access for messages originating from those addresses. Note that all access, including Read only access, is restricted by the entries.

Controls

Save Settings : Saves the settings for the ports. Until they are saved, any alterations to the settings will not take effect.

Modbus Message : Brings up the Modbus test screen, where specific messages can be sent to the system over the internet.

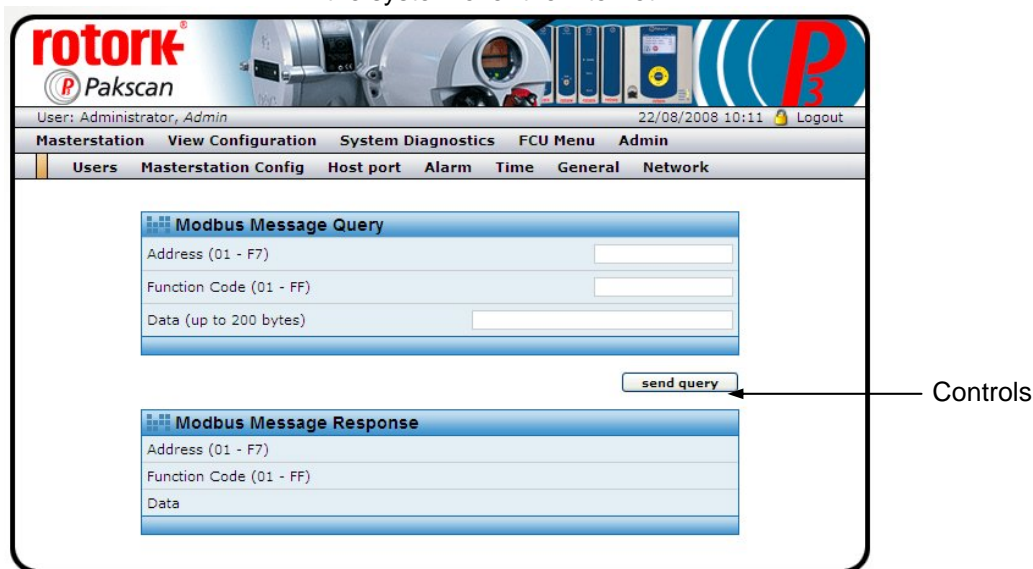

Fig 55: Modbus Message Generator

The Modbus Message screen allows a specific query to be sent to the system and the response to be viewed.

Modbus Message Query

- Address** : The CPU Master Station Modbus address (in the range 0 -247).
- Function Code** : Modbus function code to read or write register, discrete or coil.
- Data** : Modbus data relating to the query message.
There is no need to include the CRC in the data field as the system generates that automatically. There should be no spaces in the data field.

Controls

Send Query :Transmits the message to the master station.

Modbus Message Response

- Address : The address of the responding system, it will match the query address.
 Function Code : Modbus function code to read or write register, discrete or coil.
 Data : Modbus data reply, without a CRC. There will be no spaces in the data field.

Example:

Read the number of field units connected to the system; generic database is set up. Refer to S171E for the mapping of the Modbus registers. Number of FCUs is at master station register 0007. Function code 03 (holding register read) can be used. The Modbus function would be:

Modbus Address	function code	register to start read	number of registers to read
01	03	00 07	00 01

The address and function code should be entered in the relevant spaces and the data field should contain the rest of the function, this field should be entered with no spaces. When the send query button is pressed the result will be shown.

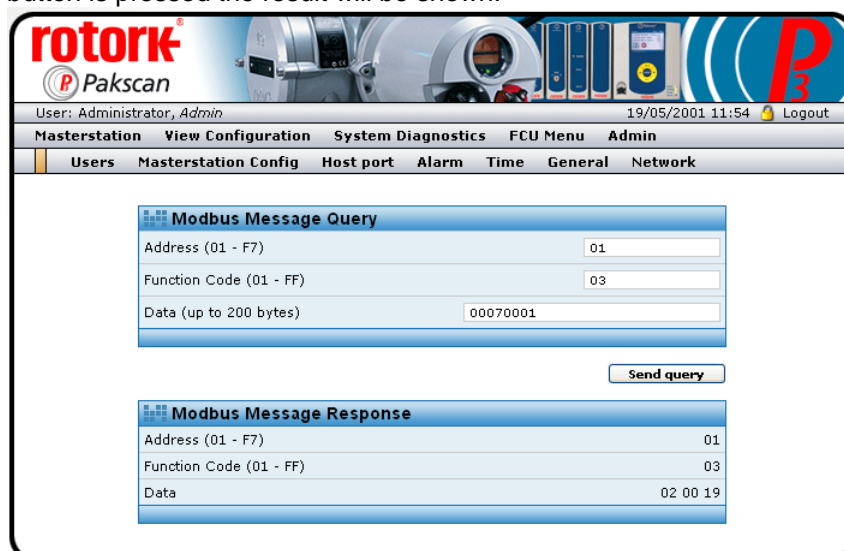

Here the data shows that 2 bytes of data are present in the message (02) and the data is 00 19. The 19hex is the number of field units fitted to the A side of the loop.

5.5.19 Alarms

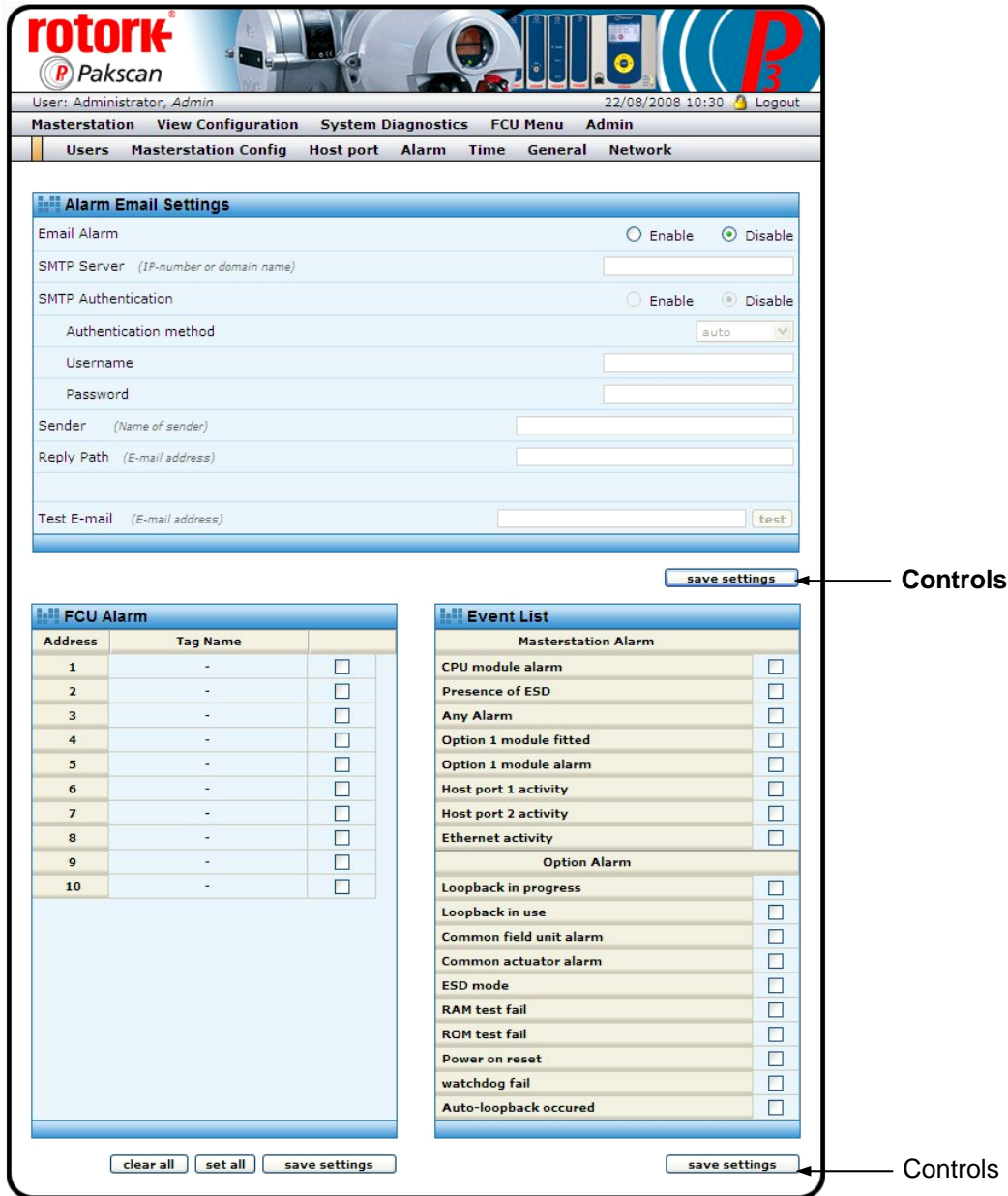

Fig 56: Alarm Reporting

This screen is only accessible to Administration user levels.

This page is used to set up the e-mail alarm reporting from the system to the dedicated recipients, as specified in the user setup screen. Each system user may be specified to receive alarm messages as e-mails or by text when their log-in credentials are specified. Refer to the section on Users to see how this is set up. The Alarm page has two sections. The first deals with the way e-mails are to be

generated and the specifying of a suitable SMTP server, whilst the second specifies which events will cause messages to be sent.

Alarm Email Settings

- Email Alarm : Set to Enable or Disable the whole process.
- SMTP Server : Specifies the server that the master station will use for forwarding e-mails. This is either a domain name or IP address for the server on which the email account has been set.
- SMTP Authentication : If the domain server supports SMTP authentication then set this to Enable and complete the Authentication parameters. (More information on SMTP Authentication can be found in Document RFC 4954 available on the internet.)
Authentication Method - auto, plain, login or cram-md5, usually set to login.
Username - the email user name for the master station or an identifier
Password - the chosen verification password for authentication of the messages from the master station to the server.
- Sender : A name to identify the master station. It could be the tag name.
- Reply Path : The email address for return messages i.e. when alarm e-mail messages are replied to.
- Test E-mail : Enter a valid e-mail address to send a test message to, in order to ensure the system is working correctly, then click on 'Test'.

Controls

- Test : Sends a test e-mail to the specified address
- Save Settings : Saves the Alarm e-mail Settings.

FCU Alarm

This table lists the devices on the field network by address and tag number. The right hand side box, when clicked, toggles between a tick and no tick. A tick indicates that if any alarm occurs on this field unit, it will be reported by the e-mail or text facility.

Controls

- Clear All : Removes any ticks from all the boxes in the list.
- Set All : Adds a tick in all the boxes in the list.
- Save Settings : Saves the FCU Alarm list settings.

Event List

This table lists all the Master station and Option card alarms that can be used to initiate an alarm e-mail or text. The list is split into two parts relating to the CPU module and the Option module.

Controls

- Save Settings : Saves the Event List settings.

5.5.20 Time

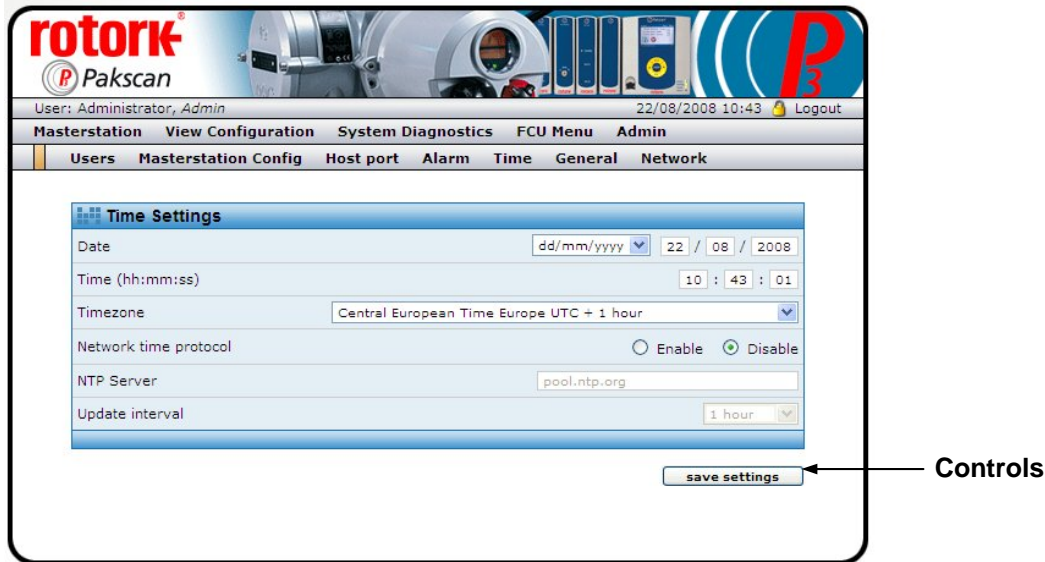

Fig 57: Time Settings

This screen is only accessible to Administration user levels.

The master station keeps track of time and date in order to correctly make events in the logs and timestamp the e-mails sent. The date can be in European or American format and the clock can be synchronised with a network server when an Internet connection is provided.

Time Settings

- Date : The date can be displayed as Day/Month/Year or Month/Day/Year by choosing from the drop down menu.
- Time : Shows the current time. This can be altered by clicking in the box and entering the new time (hr, min, sec) as required. If the system has an Internet connection this will update automatically. If there is no Internet connection, then the time can be checked periodically and corrected here.
- Timezone : Select the desired time zone from the drop down list. A new time zone entry requires that the master station reboots.
- Network Time Protocol : NTP is a protocol designed to synchronize the clocks of computers over a network. If this feature is being used it needs to be 'Enabled' by selecting the correct setting here.
- NTP Server : The time server selected is pool.ntp.org which selects from a pool of time server volunteers. Other NTP servers are available and can be used, in which case the entry here should be altered.
- Update Interval : This drop down box allows the interval between time checks with the server to be altered between 10 minutes and 2 hours.

Controls

- Save Settings : Any changes are not implemented until the Save Settings button is clicked. Changes to these settings will require a reboot of the system. The web page will prompt this.

5.5.21 General

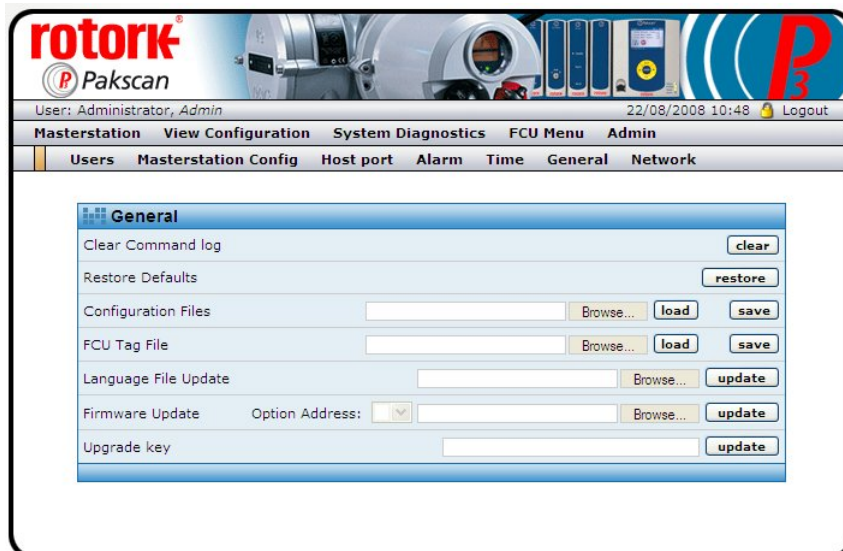

Fig 58: General Housekeeping

This screen is only accessible to Administration user levels.

General

- Clear Command Log** : The Master Station data logger (which can be found under System Diagnostics, ms datalogger) creates a file for all the recorded events. The Clear Command button empties this file. If required, the file can be saved before this process by going to the ms datalogger page and using the 'Save' facility.
- Restore Defaults** : All the default settings can be restored by clicking the 'restore' button. This facility can help in setting the master station and option cards to a known state before altering the settings for a particular system.
- Configuration Files** : The system configuration file can be saved by using the 'save' button. As default, the file will be named 'backup.nbb', but can be altered to a more meaningful name. It will be filed in a location chosen during the save routine. A previously saved file can be restored by browsing to the nbb file location and using the 'load' button.
- FCU Tag File** : The list of tag names for the field units can be saved by using the 'save' button. The saved file name is fcuconfig.xml as default and is filed in a location chosen during the save routine. A previously saved file can be restored by browsing to the file location and using the 'load' button. Modifications to the tag file can be made using a web browser and selecting the source view.

In some cases the web browser will open the fcuconfig.xml file instead of saving it. Save the file by using the 'save as' facility under the File menu on the web page. When naming the file, it will appear as fcuconfig_xml and the option of file type is presented. Ignore the options and change the file name and extension to fcuconfig.xml, then click on save. The resulting file will be in the desired xml format.

- Language File Update : To update the language files, browse to the location of the new file and click on 'load'.
- Firmware Update : To update the firmware, browse to the location of the new file and click on 'load'.
- Upgrade Key : If a new key code has been purchased (to enhance the overall system capabilities) the new code must be entered here. Type the code into the box and click on 'update'.

5.5.22 Network

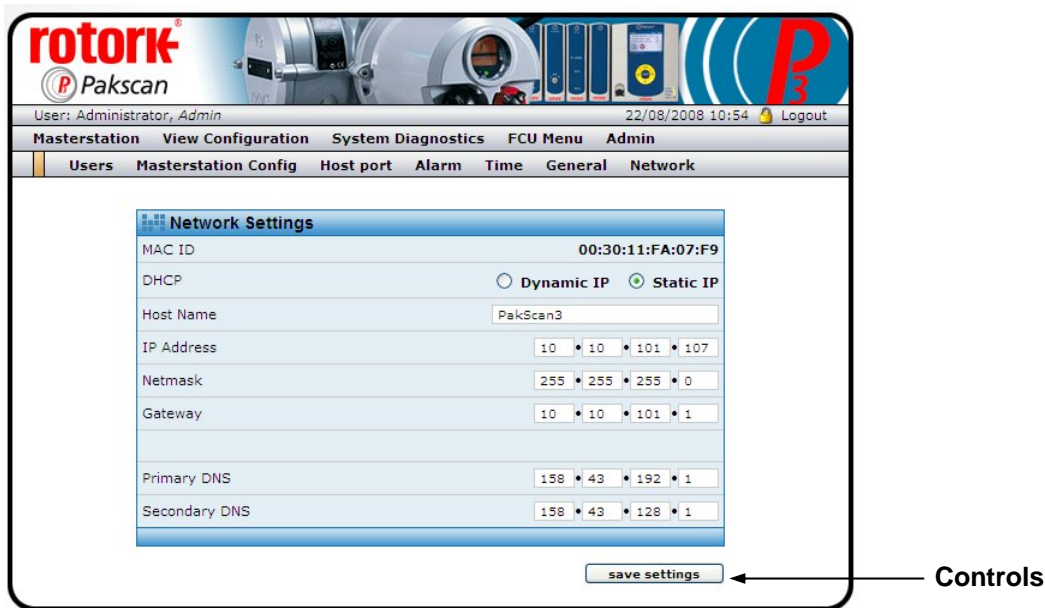

Fig 59: Network Settings

This screen is only accessible to Administration user levels.

In order to connect the master station to a network, there are several settings and IP addresses that must be set. If that network extends onto the internet, then additional settings for the gateway and DNS servers must also be added. This page allows these settings to be made.

Network Settings

- MAC ID : The unique identifier for this hardware. The Media Access Control number is embedded in the master station Ethernet port.
- DHCP : The Dynamic Host Configuration Protocol setting allows the master station to use a fixed (static) IP address or a dynamic address which it collects from the server. In practice, a fixed Static IP is usually preferred.
- Host Name : This is the identity of the basic module used in the system for reference on the Ethernet highway. The default of PakScan3 is generally acceptable and need not be altered, even if several master stations are on the same network.

- IP Address : The IP address that uniquely identifies this master station. This will generally be allocated by the network system administrator.
- Netmask : The netmask is allocated by the system administrator and set here.
- Gateway : When the master station is connected to a gateway or router onto the internet, the gateway IP address is entered here so that the master station and gateway can exchange data.
- Primary DNS : When connecting to the internet, the ISP will have two server IP addresses that are needed by the system to complete the data routing. Usually data is exchanged via the Primary Domain Name Server IP. The address is entered here.
- Secondary DNS : The second IP address supplied by the ISP.

Controls

- Save Settings : Any changes are not implemented until the Save Settings button is clicked. Changes to these settings will require a reboot of the system. The web page will prompt this.

5.6 Setting Up the Master station Configuration Using the Web Pages

In order to set up the system by the web pages it is necessary to access the system from a PC. This can either be directly connected, as described earlier, or via an Internet connection. Once the PC is connected, it is necessary to log in to the system at Administration level using the correct password. Systems are shipped with a default administrator name of **admin** and password of **admin**.



Fig 60: Log In Screen

5.6.1 Master Station Set-up page

In order to set up the system or make changes to the set-up of the system log in at administration level and select **Admin** to go to the start of the system set-up pages.

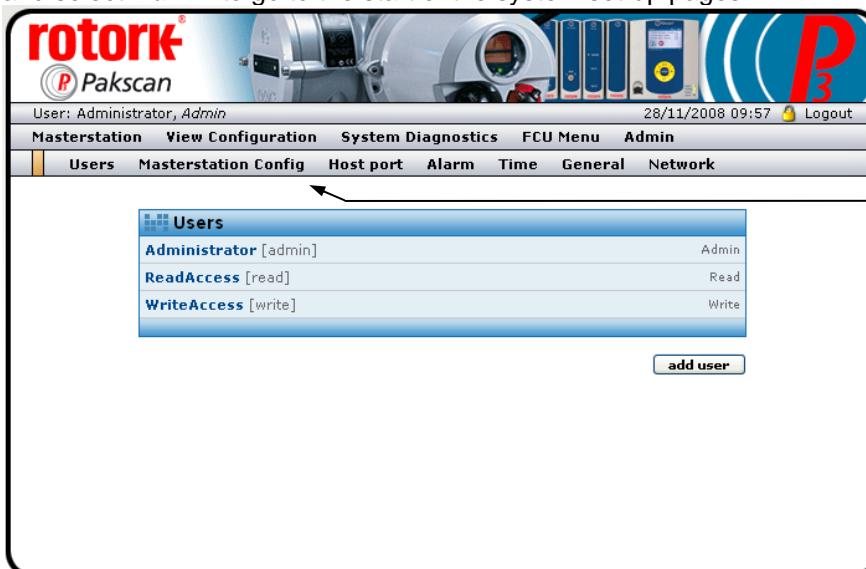

Masterstation Config

Fig 61: User Administration page

Because the system and browser remembers visited pages, either the Users page will come up, or one of the previously visited Admin level pages will appear.

Click on **Masterstation Config** to enter the main system configuration page.

The screenshot displays the 'Masterstation Configuration' web interface. At the top, there is a header with the Rotork Pakscan logo and navigation tabs: Masterstation, View Configuration, System Diagnostics, FCU Menu, and Admin. Below the navigation, there are sub-tabs: Users, Masterstation Config (selected), Host port, Alarm, Time, General, and Network. The main content area is titled 'Masterstation Configuration' and contains the following fields:

- Site name: ROTORK LAB
- Tag name: P3F-1
- Option 1 Modbus address: 240
- ESD Settings:
 - Ethernet ESD: Enabled
 - Hardwired ESD: Enabled
 - Webpage ESD: Enabled
 - Serial ESD: Enabled
- Command Settings:
 - Ethernet: Enabled
 - Serial Port 1: Enabled
 - Webpage: Enabled
 - Serial Port 2: Enabled
- Number of channels: 32
- Software version: 2.01.01

Buttons for 'print page' and 'save settings' are located below the configuration fields. Below this section is another configuration area titled 'Option 1: Pakscan 2 Loop' with the following fields:

- Software version Option 1: 1.1.1
- Highest FCU address: 10
- Loop speed: 1200
- New loop speed: N/A
- Loop speed doubling: OFF
- Retain data on loss of communications: OFF
- DV convert: OFF
- Host Port 1 Database Selection: Generic Modbus
- Host Port 2 Database Selection: Generic Modbus
- Ethernet Database Selection: Generic Modbus
- Port alarms: Separate

A 'save settings' button is located at the bottom of the 'Option 1' section.

Fig 62: Master station Set-up page

Modify this page to set up the master station parameters by using the drop-down menus on each parameter. Most default values will be suitable for getting the system started, though consideration should be made for every setting.

The Modbus address is also set on this page. Change the Modbus address to match the desired serial communications and Modbus TCP address for access to the actuators on the current loop. It should not be left at 240.

5.6.2 Option Module Set-up (including host comms protocols)

The master station set-up page is also used for setting up the Pakscan 2 Current Loop Option card. Set the loop performance parameters in accordance with the data recorded earlier. Make sure the loop speed is compatible with the setting for the loop capacitance.

Set the highest field unit address parameter equal to the actual highest address.

Doubling can be set to 'On' if the loop performance is not fast enough. It has the effect of halving the time to collect data from the field units.

DV Convert should be set to 'On' if position control is being used on the IQ, IQT, Skil or EH actuators on the network.

Data Retain set to 'Off' clears all the field unit data if communication is lost. Some host systems want the data to be retained, in which case set the parameter to 'On'.

The communications protocols are also set on this page. Select the desired host protocol on each serial communications port and the Ethernet ports for access to the actuators on the current loop.

Once the settings are as required, they must be downloaded to the master station CPU module. Click on **save settings** and wait for the web page to refresh before moving to the next task.

5.6.3 Host Port Settings

The physical parameters relating to the serial ports that may be altered are set by accessing the **Host Port** page.

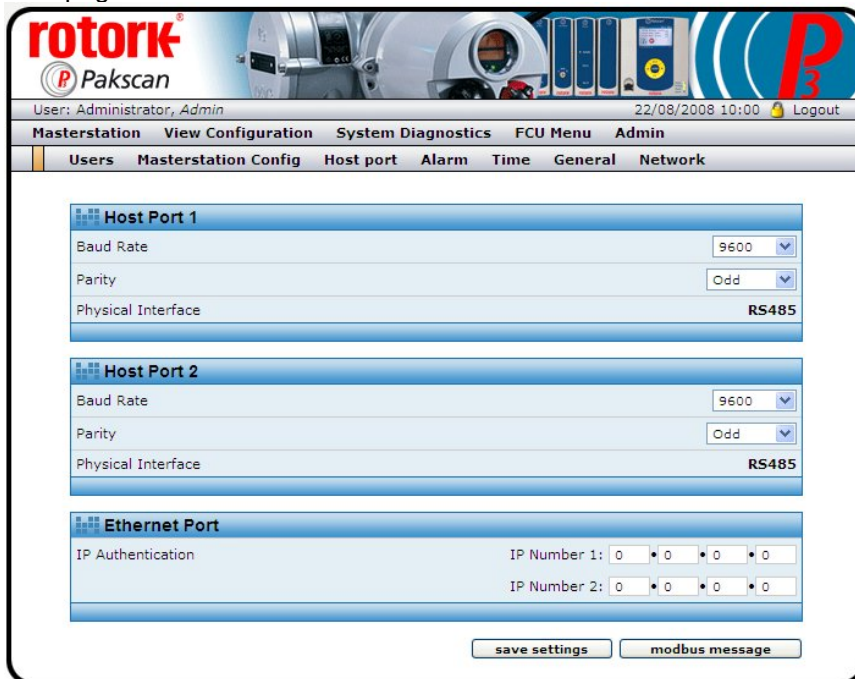

Fig 62: Host Port Set-up page

The port type is determined by the DIP switch settings on the back plane pcb and the setting is reflected in the message on the screen. The description changes to reflect the setting when the port is set to RS232. This is particularly useful when determining the settings already in place.

For each serial port, set the Baud Rate and Parity as required. The speed may be varied between 2400 and 115,200 baud, the parity may be Odd, Even, Zero or None.

The Ethernet port IP Authentication needs to be set when internet control over the web is being used. On a private Ethernet network it is unlikely that authentication will be required.

Once the serial port settings match the system requirements for communication to the host system they must be sent to the master station CPU module. Click on **save settings** to send the values to the module.

The **modbus message** button opens up a page where messages can be created and sent to the master station, one at a time. The reply is shown and can be examined to ensure that the expected performance is being obtained. Note that these messages are sent over the Ethernet link using Modbus TCP and not over the Serial link and therefore do not test all the serial port settings.

5.6.4 Setting the IP Address

The IP address for TCP/IP and Modbus TCP communication is set on the **Network** page.

The MAC ID for each Pakscan P3F CPU module is different, but fixed at time of manufacture. The IP address and Netmask can be altered to suit the individual application and match the needs of the network.

Fig 63: Network IP Address set up page.

Once the desired values have been set, click the **save settings** button to download the values to the Master Station CPU module. When the IP address is changed, the comms link will fail when the new

value becomes active in the master station. The web browser must be restarted and directed to the new IP address.

Re-establishing Ethernet Communication with a new IP address:
Because most PCs associate a MAC ID to each IP address, the chances are that the PC will not be able to re-establish communication with the master station until the PC has been rebooted through a complete power cycle.

6. MAKING THE SYSTEM WORK

ALWAYS ENSURE THE PLANT IS IN A SAFE CONDITION AND ALL THE ACTUATOR CONTROLS ARE PLACED IN LOCAL BEFORE COMMENCING ANY COMMISSIONING

6.1 Commissioning the System

The current loop needs to be commissioned to enable the system to locate and identify every actuator. The master station and laptop PC can be used to perform the commissioning. At the time of commissioning the loop all the actuators must be made available, though they may be locked in 'hand only' control. All field units must have a unique network address.

The two-wire loop and all the actuators should be connected to the master station, with all the actuators left without power, except for the one furthest from port A. Disconnect the wires from port B and browse to the master station web pages on the PC, then go to the **System Diagnostics** page.

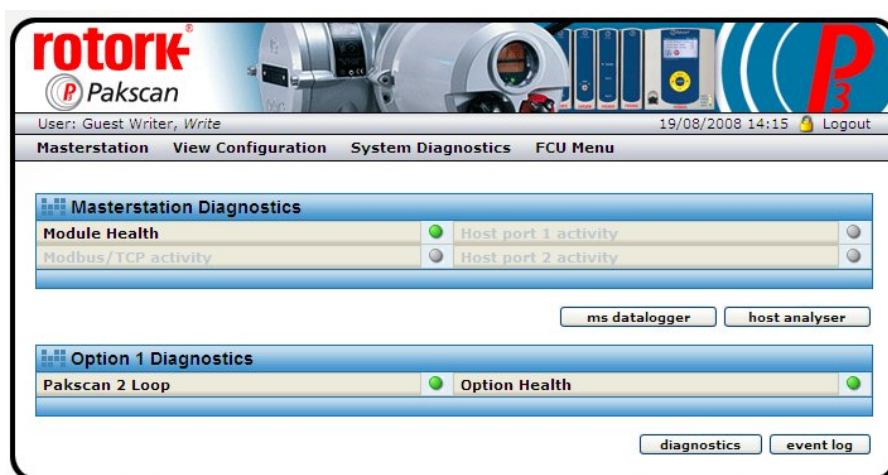

Fig 64: System Diagnostics page.

Select **Option 1 Diagnostics** by clicking on the **diagnostics** button.

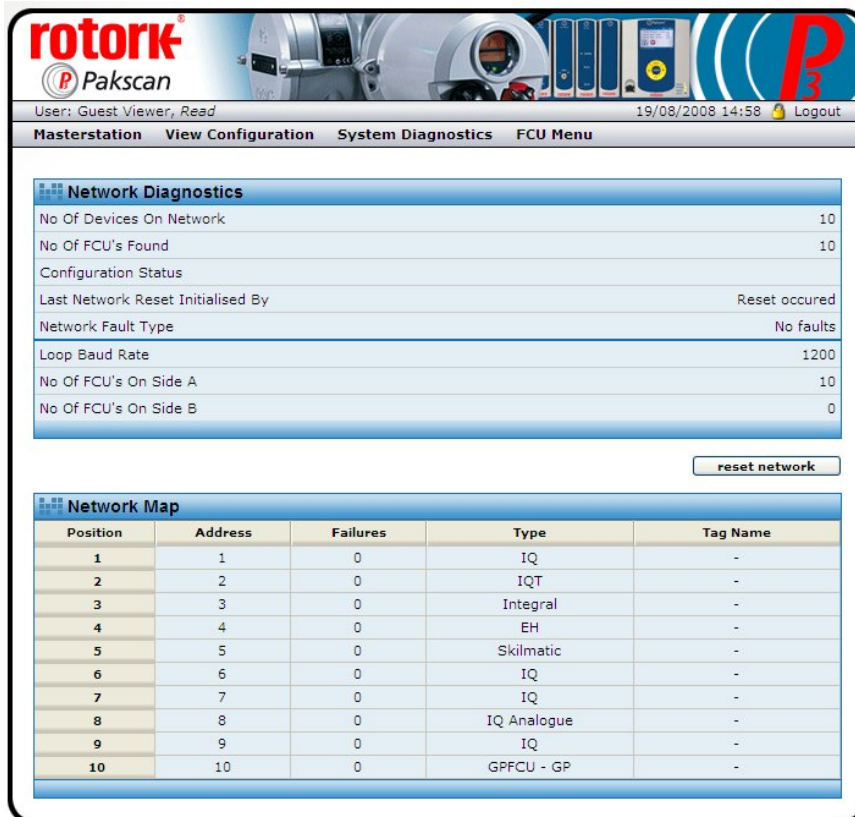

Fig 65: Pakscan 2 Option Card (Loop Card) Diagnostics page showing complete loop.

Reset the network (current loop) by clicking the **reset network** button. The status information will change and show the configuration stages. Once complete, the actuator furthest from port A should be shown on the Network Map.

Power on the next nearest actuator and reset the network again. This actuator should then appear on the list. Continue to power on the actuators and reset the network working back towards port A until all the actuators are connected and appear on the map.

Now connect the port B wires and disconnect the port A wires. Reset the network and check that all the actuators are still on the map. Having verified the loop wiring and the connection of all the actuators in both directions, finally connect the port A wires, reset the loop and all the actuators will be ready for control.

Once the system is working with actuators connected and no loopbacks present, the diagnostic and control pages can all be used.

6.2 Monitoring and Controlling the Actuators

The Web Browser includes the capability to control and monitor all the actuators on the Pakscan current loop connected to the Option Module. Go to **FCU Menu** to open the page showing all the connected actuators and their status.



Fig 66: List of Connected Field Units

This screen lists the FCUs in address order, their type and current condition. The **FCU Control** button will bring up the page showing the information in more detail.

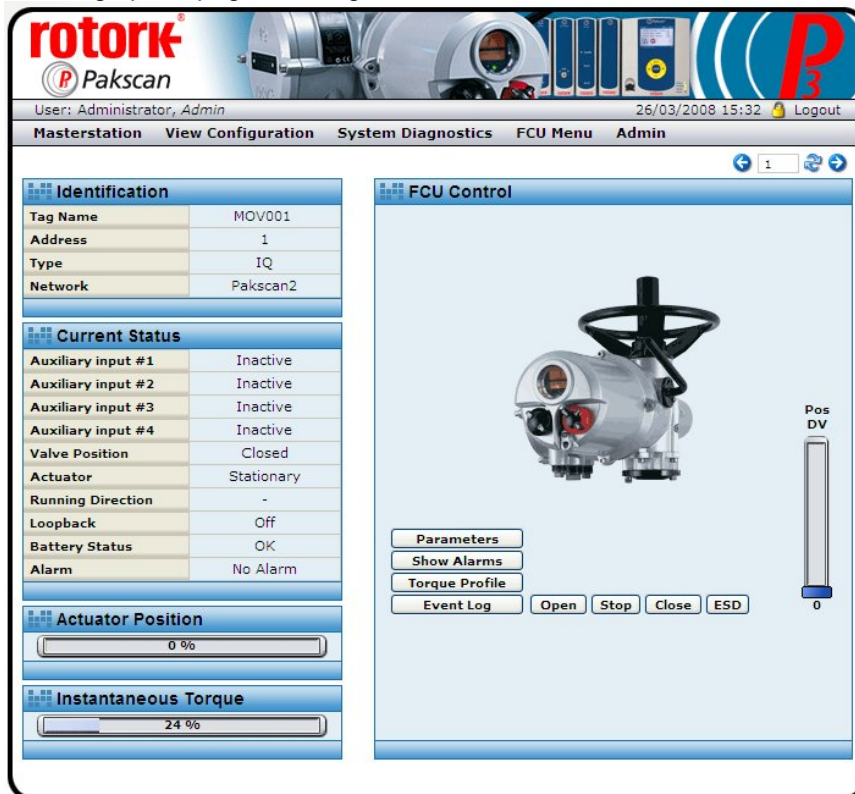

Fig 67: Detailed Actuator Condition page.

The actuator can be moved by the **Open** and **Close** buttons and any alarms present displayed by clicking **Show Alarms**. The page will automatically refresh if the valve is moved and the buttons at the top of the page can be used to move to the next or previous actuator on the network.

Once the system is running correctly, make a note of all the settings and field unit parameters for future reference.

The Pakscan Current Loop network and associated actuators will now be available for the host DCS or PLC to control and monitor the plant.

GENERAL SAFETY INFORMATION

This is customer information regarding installation, user safety, environmental and electromagnetic compatibility.

This information is provided to assist with conformance to the Health and Safety Act 1974 and various directives of the European Community.

Mechanical

Care should be taken to avoid dropping heavy items - for example during installation or maintenance. Protective footwear should be worn when appropriate. Rotork products are not intended to carry the stresses involved in support of items supplied by others unless this has been specifically agreed to by the company.

Care should be taken to avoid contact with sharp edges or points, particularly if the product is partially dismantled.

Electrical

Products should be installed in accordance with BS6739.

Electrical supplies and earthing should be in accordance with BS7671

Care should be taken to ensure that voltages or currents in excess of those specified, or of reversed polarity, are not applied to the terminals of any products. If such excess is applied, the product should be returned to Rotork or otherwise checked by a competent person before re-use, even if no damage is immediately evident. Use only the specified fuse type and rating as replacements.

Products should not be operated with safety protective covers removed, or with safety interlocks overridden. Some products are designed to allow access by skilled persons whilst power is applied. The user must control such skill level and access and it should be remembered that electromagnetic compatibility may be compromised.

Galvanically isolated input or output signal circuits are provided by certain products. A competent person must decide upon any earthing arrangements for such circuits and users should regard them as carrying a dangerous voltage, unless they are earthed locally.

Batteries

Batteries must not be short circuited, or disposed of by burning. They must not be opened, punctured or crushed. Large batteries should only be used in well ventilated places. Their cases are generally ABS plastic resin and as such should be cleaned only with a damp cloth and not exposed to organic solvents.

Electromagnetic Compatibility

To ensure conformance to the EC Directive 89/336/EEC, installation should adopt the following cable arrangements:

All digital data cables and all analogue signal cables operating at or below 50 Volts should be shielded either by braid, armouring or metal conduit.

Such shields should be earthed as closely as possible to the product. If for the avoidance of ground loops it is not possible to earth these shields locally at low frequencies, they should nevertheless be so earthed via a capacitor effective at radio frequencies.

A single shield may be shared by any number of analogue signal cables.

Functional Reliability

Reliability predictions, (including failure mode and effect analysis), are calculated by Rotork using statistical methods and the resulting figures should only be used for statistical purposes. These predictions are only valid if the maintenance procedures and maintenance intervals stated in Rotork documentation are observed.

Environmental

Products should only be operated within the environment specified on the product data sheet. Take care not to obstruct ventilation paths.

In the event of ingress of any fluid or spray, products should be immediately switched off, and cleaned and dried by a competent person before re-use.

Chemical

Specific hazards will be the subject of product data. As a matter of good working practice, oral contact should be avoided.

Independently Certified Products

Such products must not be modified in any way by the user, and must be applied, operated and maintained in accordance with the relevant standards, certificates and reports.

Product Data Sheets

These should be checked for information that supplements or replaces that given above.

(This page is intentionally blank)

rotork

<http://www.rotork.com>

Rotork reserves the right to amend and change specifications without prior notice.

Published data may be subject to change

UK Head Office

Rotork Controls Ltd
Bath
England
BA1 3JQ

Tel: +44 (0) 1225 733 200
Fax: +44 (0) 1225 333 467
e-mail: mail@rotork.co.uk

USA Head Office

Rotork Controls Inc
675 Mile Crossing Blvd
Rochester
New York 14624
USA

Tel: +1 585 247 2304
Fax: +1 585 247 2308
e-mail: info@rotork.com