

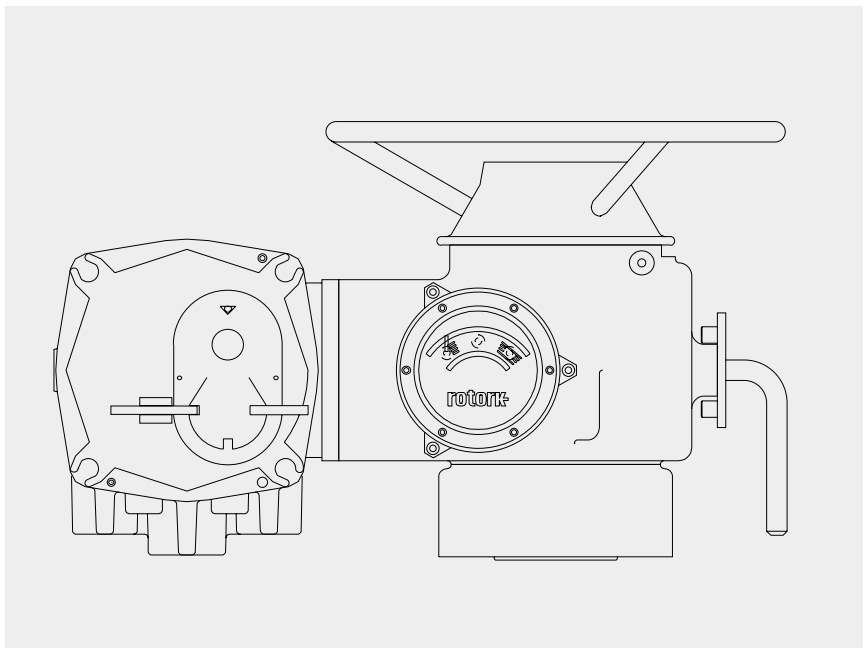

Instruction manual for 'A' Range actuators



Syncropak 1400 series
Syncropak 1600 series
Syncroset

This manual is produced to enable the user to install, operate, adjust, inspect and maintain Rotork A range valve actuators. For the UK the electrical installation, maintenance and use of these actuators should conform to the requirements of the Electricity (Factories Act) Special Regulations 1908 and 1944 and the guidance given in the 15th edition of the IEE Wiring Regulations. The user should therefore make himself familiar with these regulations and other Statutory Provisions relating to the safe use of this equipment. Also the user should be fully aware of his duties under the Health and Safety at Work etc. Act 1974.

The mechanical installation should be carried out as outlined in the manual and also in accordance with the relevant British Standard Codes of Practice.

If the actuator has nameplates indicating that the actuator is suitable for installation in Hazardous Gas Areas then the following regulations apply. The electrical installation, maintenance and use of these actuators should be carried out in accordance with BS 5345 Part 1: 1976 and BS 5345 Part 3: 1979. No inspection or repair should be undertaken unless it conforms to the requirements given in these standards, and under no circumstances should any modification or alteration be carried out on the actuator as this could very well invalidate the conditions under which the certificate was granted.

These actuators are suitable for use in Zone 1 and Zone 2 explosive atmospheres only, and they should not be installed in atmospheres where Group II C gases are present, or where gases are present with an ignition temperature less than 135C. Unless suitability for lower ignition temperatures has been indicated on the actuator nameplate. Any test instruments applied to the actuator should be of equivalent certification.

Access to live electrical conductors of the actuator is forbidden in the hazardous area unless this is done under a special permit to work as described in Section 3 of the manual, otherwise all power should be isolated and the actuator removed to a non hazardous area for repair or attention.

Only persons competent by virtue of their training and experience should be allowed to install, maintain and repair these actuators, and they should carry out this work in accordance with the instructions given in the manual. The user and those persons working on this equipment should be familiar with their responsibilities under the Health and Safety at Work etc. Act 1974 and relevant Statutory Provisions relating to their work. For installations outside the UK the requirements of local regulations should be observed. Should further information and guidance relating to the safe installation, maintenance and use of the Rotork A Range actuator be required, this will be provided on request.

If your actuator cannot be installed immediately store it in a dry place until you are ready to wire up.

If the actuator has to be installed but cannot be wired up it is recommended that the plastic cable entry plugs are replaced with metal plugs which are sealed with PTFE tape.

The Rotork double sealed construction will preserve internal electrical components perfectly if left undisturbed.

Rotork cannot accept responsibility for deterioration caused on site once the actuator covers are removed.

Every Rotork actuator has been fully tested before leaving the factory to give you years of trouble free operation providing it is correctly installed and sealed.

WARNING

With respect to handwheel operation of Rotork electric actuators, under no circumstances should any additional lever device such as a wheel-key or wrench be applied to the handwheel in order develop more force when closing or opening the valve as this may cause damage to the valve and or may cause the valve to become stuck in the seated/backseated position.

1 Operating your Rotork actuator

- 1.1 Operating by hand
- 1.2 Operating electrically
- 1.3 Valve position indication

2 Preparing the drive bush (type A + AZ)

- 2.1 Removing drive bush
- 2.2 Replacing drive bush
- 2.3 Removing drive bush (type AR + AE)

3 Mounting actuator on valve or gearbox

- 3.1 Rising stem valves, top mounting
- 3.2 Valve gearboxes, side mounting
- 3.3 Non-rising stem valves, top mounting
- 3.4 Handwheel sealing

4 Wiring up

- 4.1 Ground connections
- 4.2 Removing terminal cover
- 4.3 Sealing conduit entries
- 4.4 Connecting terminals
- 4.5 Replacing terminal cover

5 Setting instructions

- 5.1 Switch mechanism
 - 5.1.1 How to check if your actuator has already been properly set
 - 5.1.2 Setting the limit switches to operate at either end of valve stroke
 - 5.1.3 Selecting torque or limit control
 - 5.1.4 How to select torque values
 - 5.1.5 How to replace switch mechanism cover
- 5.2 Optional extras
 - 5.2.1 Setting intermediate auxiliary switches (AOP1 only)
 - 5.2.2 Setting the potentiometer
 - 5.2.3 Setting the Current Position transmitter (CPT)
 - 5.2.4 Blinker
 - 5.2.5 Folomatic proportional control (Syncropak only)
 - 5.2.6 Interrupter Timer (Syncropak only)
 - 5.2.7 PA Failsafe actuators

6 Electrical start-up

- 6.1 Checking rotation
- 6.2 Syncropak actuators (1400 series)
- 6.3 Syncropak actuators (1600 series)
- 6.4 Syncroset actuator

7 Trouble shooting

- 7.1 Syncropak actuators
- 7.2 Syncroset actuators
- 7.3 All actuators

8 Lubrication and maintenance

- 8.1 Oil
- 8.2 Oil fill/drain plugs
- 8.3 Maintenance
- Appendix 1

9 Service and spares

Details of sub-assemblies available.

Rotork Syncroset actuators

Each standard Syncroset consists of four basic sub-assemblies:

- a** Motor
- b** Oil-filled worm gearbox with handwheel and declutch mechanism
- c** Limit and torque switch mechanism
- d** Terminal box



Integral Syncroset

Rotork Syncropak actuators

Each standard Syncropak consists of four basic sub-assemblies:

- a** Motor
- b** Oil-filled worm gearbox with handwheel and declutch mechanism
- c** Limit and torque switch mechanism
- d** Integral starter and associated control equipment



Standard Syncroset



Syncroset DC



*Standard Syncropak
(or Flameproof Syncroset with
Pushbuttons)*



*Standard Syncroset with
pushbuttons*

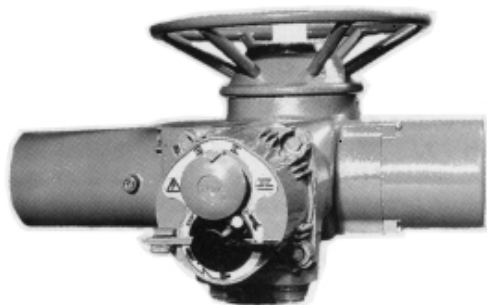

*Integral Syncroset with
pushbuttons*

1 Operating your Rotork actuator

Throughout this publication you will be referred to procedures which will require you to operate your actuator either by hand or electrically.

Actuators must not be allowed to run valve to end of travel until correct motor rotation has been established.

Both operations are simple. The various controls which you will need to use are as follows.

1.1 Operating by hand

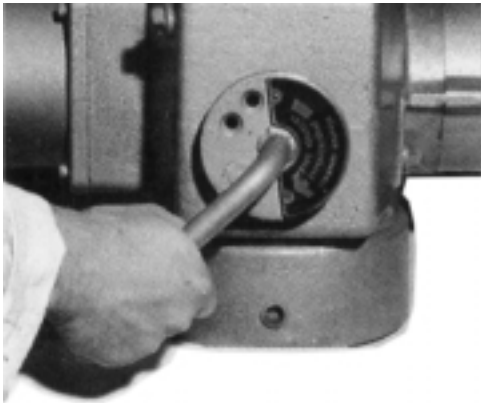

To engage handwheel, depress clutch lever into 'hand' and turn handwheel to engage clutch. The lever can now be released.

The hand drive will remain engaged until the actuator is operated electrically when it will automatically disengage the handwheel and return to 'auto'. If required the clutch lever can be secured in either position with a 5/16" diameter hasp padlock.

1.2 Operating electrically

Selecting local or remote control(Syncropak only):

The black selector switch located on the starter cover can be turned to select any one of the three control positions: 'local', 'remote' or 'stop'.

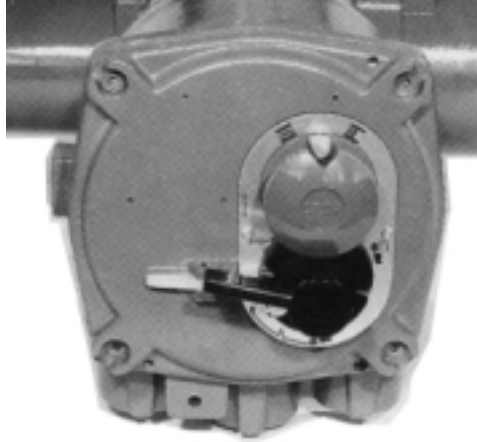

On 1600 series, 'local' and 'remote' are represented by the following symbols:

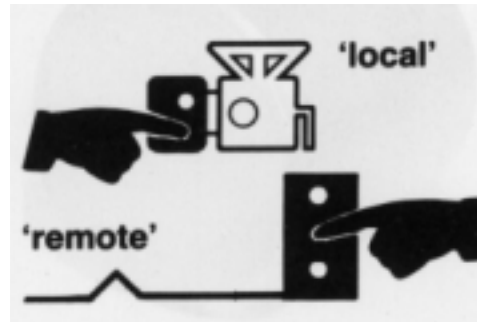

When selecting 'stop' note that the selector switch lever rides over and automatically depresses the red pushbutton into the 'stop' position.

Any position can be maintained by using a 1/4" diameter hasp padlock.

To open or close the valve or stop the actuator:

The red pushbutton on the starter cover has two functions: push to stop, turn to start, in either direction.

1.3 Valve position indication

Valve position is indicated mechanically by pointer and dial and, when live, by indicator lamp on Syncropak unit as follows:

Valve position	illumination	symbol
Open	red	
intermediate	white	
shut	green	

Note that the pointer stays central during valve travel. When Add-on-pak 1 is fitted, pointer movement is continuous between 'shut' and 'open'.



2 Preparing the drive bush

Rotork actuators are supplied fitted with a drive bush which can be detached for machining to suit the valve stem.

2.1 Removing drive bushes on actuator types A and AZ

Engage hand and turn handwheel until retainer set screw is visible through hole in actuator base.

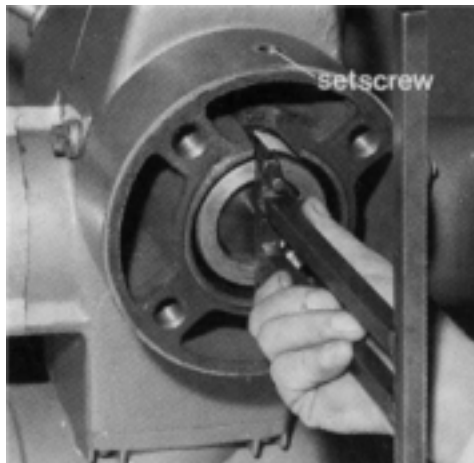

Loosen set screw and unscrew retainer using hammer and punch. Remove drive bush and machine to suit valve stem or gearbox input shaft.

Allow apparently excessive clearance on screw thread for old rising stem valves



Type A drive bush

If the actuator has a type A drive bush, this can be fitted in position 1 or 2 to suit the position of the valve mounting flange.

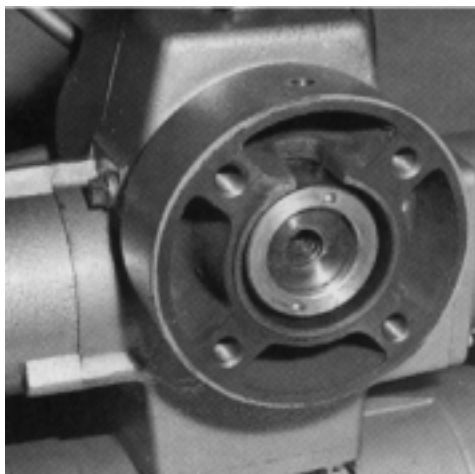

Type A drive bush in position 1

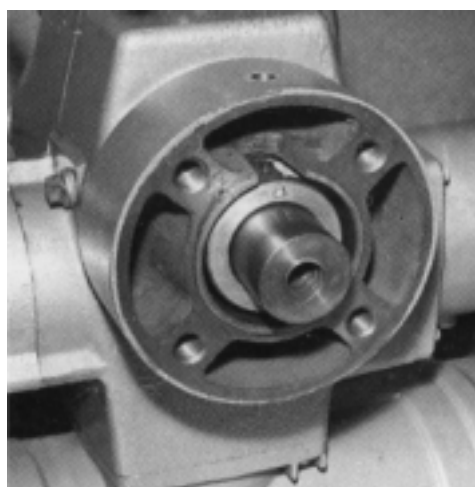

Type A drive bush in position 2

If it has a type AZ drive bush this can only be fitted below the actuator base to give the maximum stem diameter acceptance.

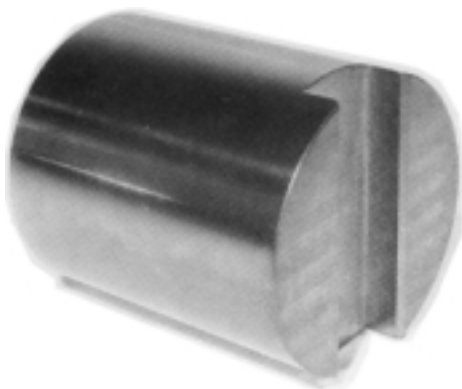

Type AZ drive bush

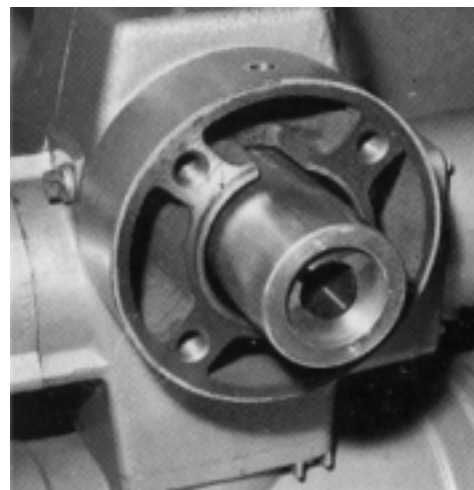

Type AZ drive bush in position 3

2.2 Replacing the drive bush

Having confirmed the position required, insert the machined drive bush ensuring that the actuator output shaft dogs are in full engagement with the bush.

Fit drive bush retainer securely, turning clockwise until fully tightened using hammer and punch. Rotate by handwheel to align retainer set screw with hole in base and lock tight.

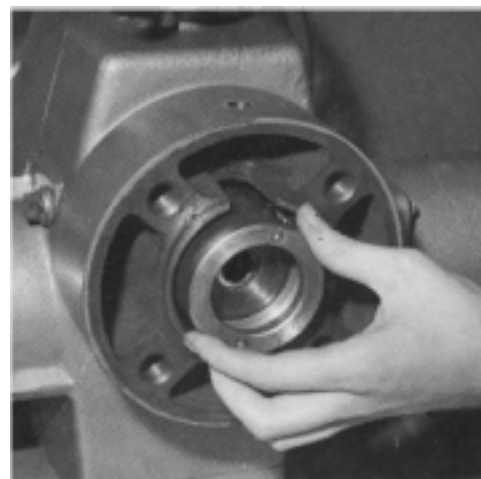

2.3 Removing drive bush on actuator types AR and AE

These drive bushes are retained in the actuator without screwed retainers.

3 Mounting actuator on valve or gearbox

Actuator to remain fully supported until full spindle engagement has been achieved and actuator base is located to valve flange, and secured.

It is assumed that the valve has a mounting flange to suit the actuator.

3.1 Rising stem valves, top mounting

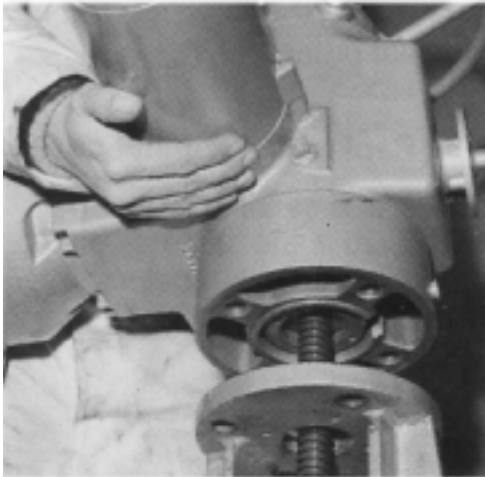

Lower the actuator on to the valve stem, engage 'hand' and wind the handwheel in the opening direction to engage the thread on the valve stem. Continue winding until the actuator is firmly down on the valve yoke. Wind two further turns of the output shaft.



Fit securing screws or nuts and tighten fully.

3.2 Valve gearboxes, side mounting

Check that the valve mounting flange is at right angles to the input shaft, and that the drive bush fits the shaft and keyway with adequate axial tolerance. Engage 'hand', offer up actuator to the input shaft and turn handwheel to align keyway and key. Bolt up tight.

3.3 Non-rising stem valves, top mounting

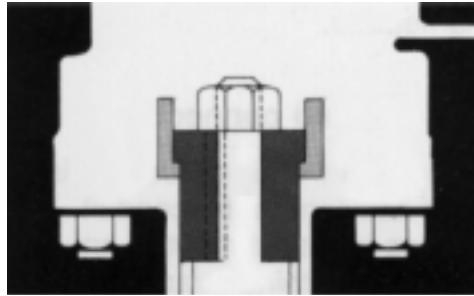

Treat as for side mounting except that, when thrust is taken in the actuator, the thrust nut above the drive bush must be securely tightened.

3.4 Handwheel sealing

Ensure that sealing plug in centre of h/w or spindle cover tube (depending on which is fitted) is sealed with PTFE tape and fully tightened, ensuring that moisture does not pass down the centre column of the actuator.

4 Wiring up

Check that supply voltage agrees with that stamped on actuator nameplate.

4.1 Ground connections

A lug with 1/4" diameter hole is cast adjacent to the conduit entries for attachment of an external earthing strap by nut and bolt. An internal earthing terminal is also provided.

4.2 Removing terminal cover

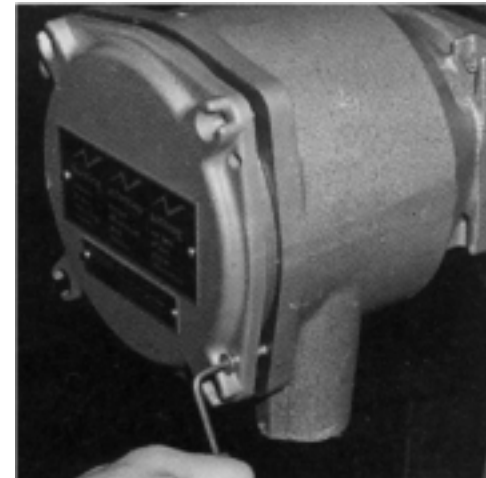

Use two of the cover retaining screws in the jacking holes.

Do not attempt to lever off with screwdriver as this will spoil 'O' ring seal and may damage the flame path on a certified unit.

Note the wiring code card fixed inside the cover. This is particular to each actuator and must not be interchanged with any other actuator. If in doubt check serial number on nameplate with that on code card.

Unscrew earthing terminal nut and remove plastic bag containing wiring diagram, terminal nuts and spare 'O' rings.

5 Setting instructions

4.3 Sealing conduit entries

Conduit entries should be sealed in accordance with surrounding environment and with any requirements of the regulatory authority.

Seal unused entries with threaded metal plugs. Do not use plastic plugs if supplied with actuator.

4.4 Connecting terminals

Refer to the wiring diagram inside the terminal cover to identify functions of terminals. Check that supply voltage is the same as marked on the code card and actuator nameplate. Remove transparent power terminal screen, and begin wiring the power terminals.

Note: Syncroset and Syncropak 1400 series

Correct phase rotation is essential for electrical operation and must be checked at start-up stage. All Rotork Syncroset and Syncropak 1400 series 3 phase actuators are tested for correct operation with phase rotation in terminal order 1,2,3.

4.5 Replacing terminal cover

Check that serial number on code card is the same as on the actuator nameplate before replacing cover with its 'O' ring in position.

5.1 Switch mechanism

There are two basic operations which have to be carried out:

- 1 Setting the switches to operate at either end of the valve's stroke
- 2 Selecting the correct 'torque' or 'limit' function for your particular valve and possibly adjusting the torque value for your particular application.

If you have already received a complete motorized valve these operations should already have been carried out.

5.1.1 How to check if your actuator has already been properly set

With the actuator firmly bolted to the valve engage handwheel drive.

Fully open the valve by hand and check that the position indicator pointer moves over to the 'open' position just before the handwheel reaches its stop.

Fully close the valve by hand and check that the pointer moves over to the 'shut' position just as the valve seats.

If the indicator is reading correctly at both ends of stroke, you can assume that your valvemaking has already carried out the detailed setting instructions which follow and you can proceed directly to Section 6 Start-up.

If you have bought your actuator separately from the valve or if the check was negative you must now go through the following procedure.

5.1.2 Setting the limit switches to operate at either end of valve stroke

Note: Instructions are for 'clockwise closing'. For 'anticlockwise' read 'opening' as 'closing' etc.



Mount your actuator on the valve, see section 3. Remove the switch mechanism cover as follows:

Remove the three retaining screws adjacent to gear case using a 5/32" AF Allen key. (5mm if cenelec enclosure.)

Pull off cover squarely with both hands. Do not attempt to lever cover off with a screwdriver. This is likely to damage the 'O' ring and may also damage the flame path on a certified unit.

Engage handwheel drive. (see section 1.)

See Fig. 1. Break open locknuts 17 and 18 and run both back to outboard end of screwed shaft 15. Leave loose. Loosen clutchnut 22 by turning anticlockwise at least three full turns.

Note that the screwed shaft can now be turned with the fingers. As you turn it note that travelling nut 16 moves up and down the shaft.

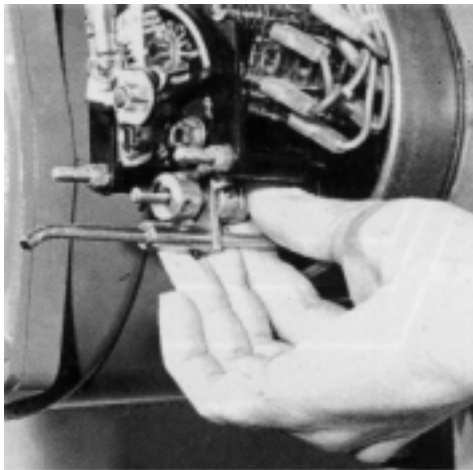

Turn actuator handwheel until valve is closed as far as mechanically possible.

Turn screwed shaft 15 anticlockwise with your fingers until you feel the travelling nut comes hard up against its backstop 19.

Gripping screwed shaft between your thumb and first finger you will be able to continue to turn it, by using the overtravel guide 20 for leverage. Continue to turn until overtravel guide comes up against overrun stop 21.

During this final movement you will have heard the switches click.

Holding overtravel guide hard over against its stop, tighten clutchnut.

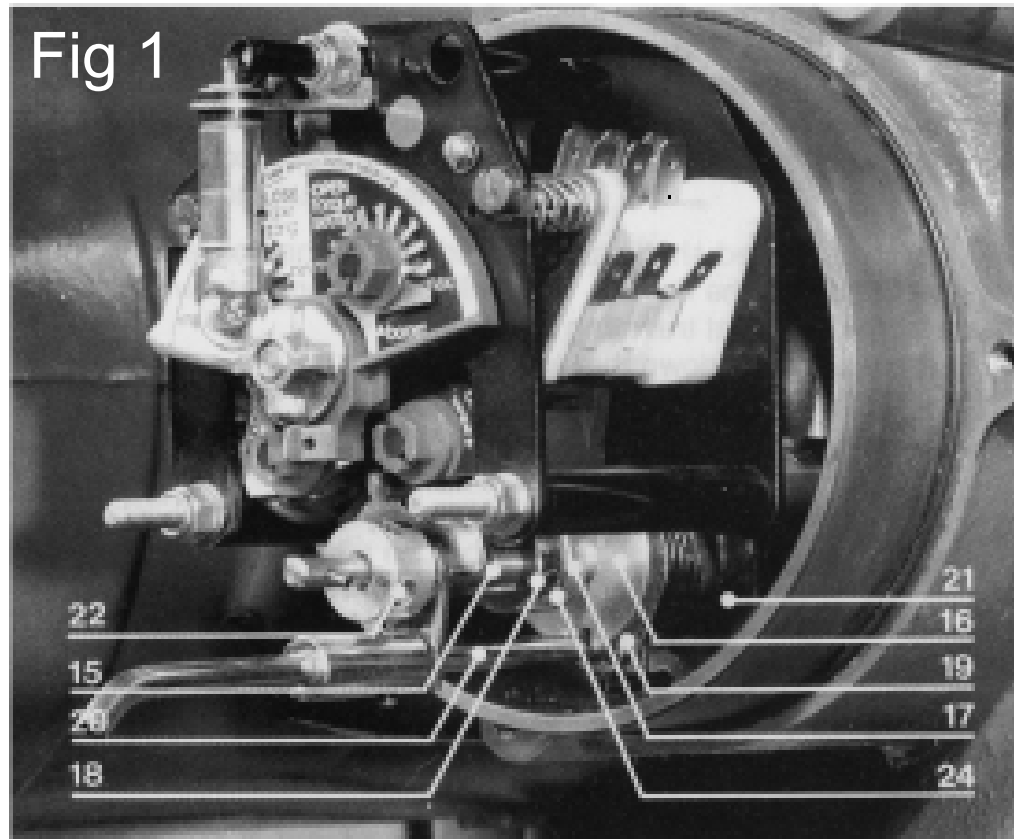

After tightening clutchnut, you can release your pressure on the overtravel guide. Apart from nominal backlash on releasing pressure, the overtravel guide should not move away from stop and the switches should not be heard to reset. If you hear a 'click' at this stage you have not carried out the preceding instructions correctly.

The 'close' switches are now set so that they trip just before the mechanical stop is reached. For valves with limit functions on closing, check shut position by operating electrically. If valve does not fully shut, handwind to mechanical stop, loosen clutchnut 22 and allow overtravel guide 20 to return to neutral position. Turn screwed shaft 15 anticlockwise, with the aid of overtravel guide, to just beyond position where all switches are heard to operate but before overtravel guide hits stop 21. Tighten clutchnut and ensure switches do not reset when guide is released.

Now wind the valve open as far as mechanically possible. Do not then wind it back a fraction 'for safety's sake'.

Using one finger, pull overtravel guide (20) over clockwise, until it comes hard up against its stop (21). Keep it hard over in this position. Switches will have been heard to click during this operation.

With overtravel guide still held hard over, run locknut 17 clockwise down screwed shaft until it comes up hard against travelling nut.

Push washer 24 down screwed shaft until it is against locknut 17 then run locknut 18 down until it clamps both locknuts and washer together. Lightly tighten locknut 18.

Release pressure on overtravel guide. Overtravel guide should stay put against stop and switches should not be heard to reset. If a 'click' is heard after releasing the pressure on the overtravel guide you have not carried out the preceding instructions correctly.

The 'open' switches are now set. By following the procedure exactly you have ensured:

1 That the switches are set to cut off the motor before the valve reaches its end of travel and that the motor has time to come to rest.

2 That manual operation of the valve can never alter the switch operating point which you have set.

5.1.3 Selecting torque or limit control

Check if the correct torque or limit functions have already been selected as follows:

With the switch mechanism cover still removed check the position of the 'open' and 'close' torque/limit selectors. They should tally with

the torque or limit positions on the table below, or with your valvemaker's specific instructions.

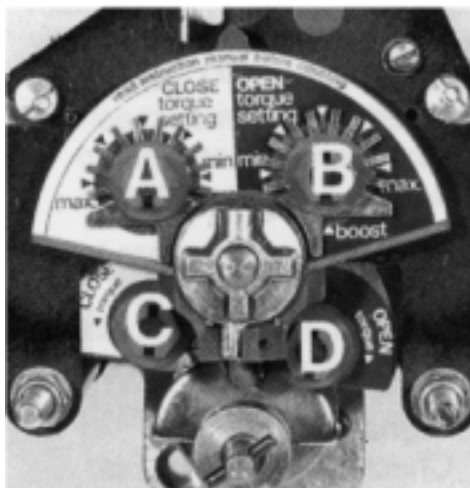

If necessary, dial selectors C and D to suit your particular valve.

Select the correct torque or limit functions for your valve as follows:

If you have bought a complete motorized valve, your valvemaker will probably have made the correct torque or limit selection to suit his own valve.

In the absence of specific valvemaker's instructions, use the following basic table:

Valve type	'close'	'open'
Wedge gate or globe	'torque'	'limit'
butterfly, thru conduit ball, plug, sluice gate or parallel slide	'limit'	'limit'

5.1.4 How to select torque values

Selectors A and B adjust the amount of torque which can be applied to the valve before the torque switch cuts out the motor.

Ideally, only the minimum torque necessary to achieve tight shut-off should be applied. In practice this value will vary from valve to valve and fluctuate with temperature, use, service etc.

We recommend that you dial selector A which controls closing torque to the first marked calibration from the MIN position. But be prepared to remove the switch mechanism cover after start-up to increase the torque value if tight shut-off is not being achieved with your original setting.

Selector B which controls opening torque should be dialled to MAX unless the valvemaker's specific instructions recommend against this.

Torque setting adjusters are fitted with locking tabs to discourage unauthorised tampering with original settings. After adjusting 'open' and 'close' torque to required value, lock setting by bending up appropriate tabs each side of pointer. If no open torque limit is required, turn open torque adjuster pointer to boost position, where no locking is required.

5.1.5 How to replace switch mechanism cover

Ensure that indicator lamp support, if fitted, is central. Ensure that O-ring is in good condition (spare may be found in terminal box).

Offer cover up squarely to spigot, register and push on. Tighten the three securing screws.

5.2 Optional extras

5.2.1 Setting intermediate auxiliary switches (AOP1 only)

Note: Add-on-Pak 1 setting is entirely independent of the switch mechanism.

For Add-on-Pak 1 to be supplied fitted to the actuator, the number of turns must have been specified at the time of ordering and its gear ratio should therefore be correct.

Add-on-Pak 1 incorporates a scale adjusting mechanism to align the pointer movement with scale length. This may have been preset to suit the valve. Both of the above may be checked by hand operating the valve full stroke; the pointer should move continuously from 'shut' to 'open'. If it does not, the scale adjuster setting or the gear ratio may be incorrect, see publication AE5/4.8 in Maintenance and Spare Parts manual.

If it operates correctly, you have only set the switches to trip at the required valve positions.

Note: Instructions are for 'clockwise closing'. For 'anticlockwise' read 'opening' as 'closing' etc.

From a suitable mid-travel position operate valve to the point at which switches are required to trip in closing direction.

Loosen nut 10 at rear of cam shaft. Set inner cam 12 so that it just trips switches IAS4, 5 and 6. Partially tighten nut.

Operate the valve to the point at which switches are required to trip in opening direction.

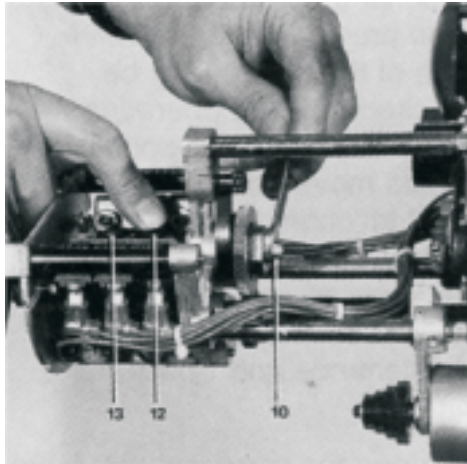

Loosen nut 10 again, set outer cam 13 to trip switches IAS1, 2 and 3. Tighten nut to approximately 10lbs in (0.6Nm)

Do not over-tighten.

5.2.2 Setting the potentiometer

For potentiometer drives fitted to the switch mechanism only:

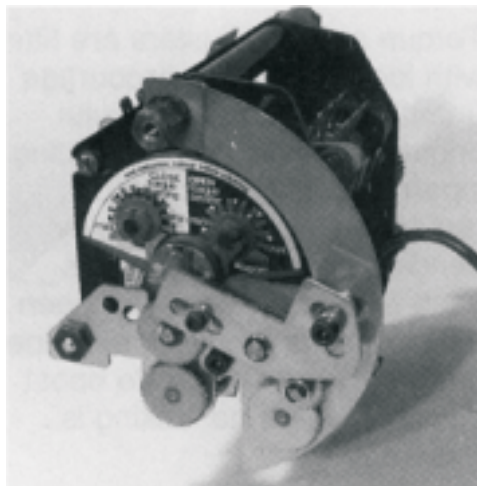

Close valve.

Loosen outer Allen screw which clamps the variable gear mounting plate and disengage gear drive to potentiometer. Turn gear coupled to potentiometer clockwise looking on front of switch mechanism until firm stop is felt. Turn potentiometer gear back approximately 15°. Re-engage the gear train and clamp the variable gear mounting plate.

For potentiometer drives fitted to AOP1 (valve should be fully open): Normally the correct potentiometer gear will be meshed with the main potentiometer drive gear to suit the number of actuator output turns specified for full valve travel.* Having noted which gear has been selected, unclamp the potentiometer assembly from its mounting pillar using a 3/32" AF Allen key. Un-mesh the potentiometer gear and rotate the potentiometer spindle anti-clockwise so that it is about 2 away from the end of its travel.

* See publication AE5/4.8 for correct selection if necessary.

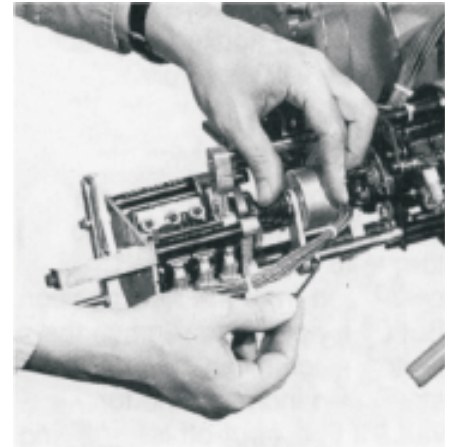

Mesh with the correct gear and clamp.

5.2.3 Setting Current Position Transmitter (CPT)

The CPT gives continuous indication with adjustment for span and zero settings and can be either internally or externally powered. For a CPT with PCB mounted in the switch mechanism compartment please refer to paragraph 5.8.2 for settings.

The following settings are for the CPT mounted behind the pushbutton cover as shown on fig. A overleaf.

1 Signal direction

a Check whether valve is clockwise or anti-clockwise to close.

b Using fig. A overleaf locate the dual links J7. For clockwise to close valve with low signal at open, link J7 must be positioned parallel to the edge of the PCB.

c For clockwise to close valves with low signal at open, and for anti-clockwise to close with low signal at closed, link J7 must be positioned at right angles to the edge of the PCB.

2 Settings

a Move valve to the low signal end of travel.

b Adjust the CPT zero trimmer potentiometer to the required minimum signal.

c Move valve to the high signal end of travel.

d Adjust the CPT span trimmer potentiometer to the required maximum signal.

e Move the valve back to the low signal end of travel and recheck the low reading and adjust if necessary.

The following instructions are for a CPT with a PCB mounted in the switch mechanism compartment (see fig. B).

Fig A

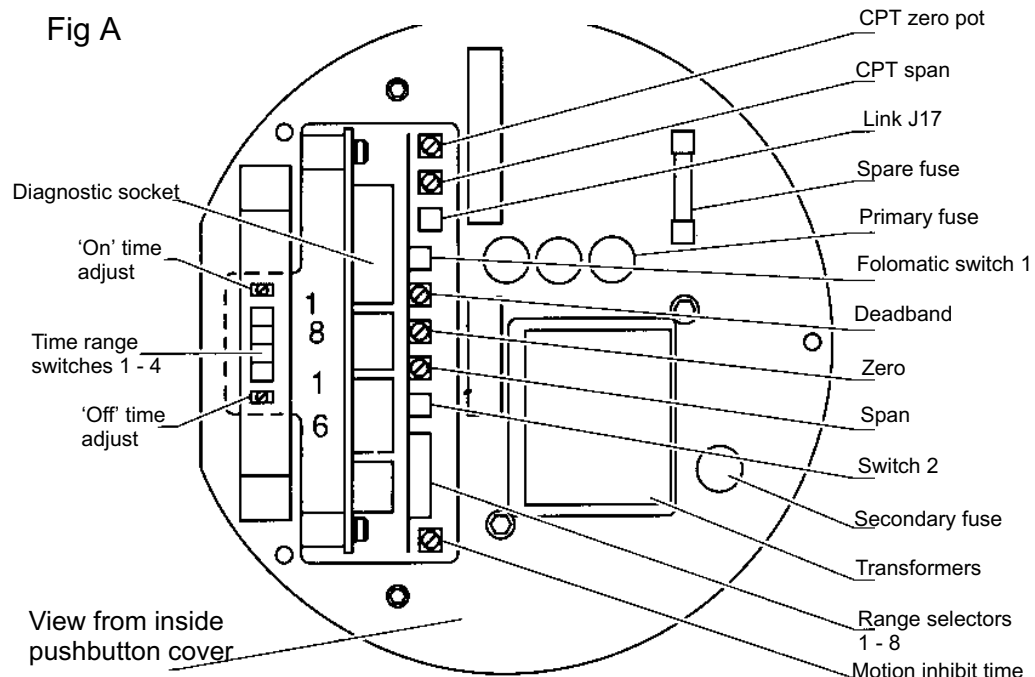

View from inside pushbutton cover

a First set actuator torque and limit switches as above, run the actuator to the fully closed position.

b Set the mechanical zero of the potentiometer transmitter, checking that the correct gears are selected to suit full travel.

c Check that the remote connections to the CPT are suitable for internally or externally powered systems as applicable. (See actuator wiring diagram).

d With the valve closed, set minimum required signal by adjusting zero potentiometer on CPT PCB.

e Operate valve to fully open position and adjust span control to give required maximum signal. For maximum signal indication corresponding to valve closed position, isolate DC supply, interchange outer connections on potentiometer, re-engage potentiometer drive gear so that it is fully clockwise with the valve fully open and then repeat zero and span adjustments as above with DC supply re-connected.

5.2.4 Blinker

The blinker is factory set to suit the actuator output turns range and no further setting is normally required.

5.2.5 Folomatic proportional control

Zero/Span/Timer/Deadband

The Folomatic Proportional Control module sets the valve position relating to an input signal with adjustments for Zero and Span setting. Refer to the wiring diagram supplied in the actuator and also the customers instructions for exact setting.

When the actuator Local/Off/Remote selector is set to 'Local' the actuator functions like any other with Open/Stop/Close local control. The actuator should therefore be set to work initially under local control in accordance with this instruction book.

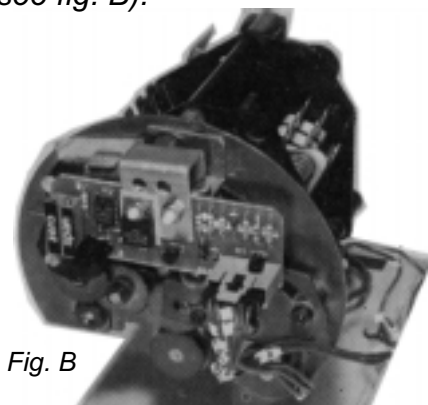

Fig. B

Setting the integral type Folomatic

The following instructions are for actuators with Folomatic settings behind the pushbutton cover (see fig. A).

1 Determine whether the valve is clockwise or anti-clockwise to close and also whether it is to open on a low demand signal.

Using fig. A locate switches 1 and 2, select as follows:

a For clockwise closing valves
Input signal low to close, SW1 selected towards edge of board, SW2 selected away from edge of board.

Input signal low to open, SW1 selected away from edge of board, SW2 selected towards edge of board

b For anti-clockwise closing valves
Input signal low to close, SW1 and SW2 away from edge of board.

Input signal low to open, SW1 and SW2 towards edge of board.

2 Determine what control input signal is going to be used, refer to Appendix 1, page 18 and locate the block of DIL switches and select the range required.

Note: If the range required was indicated at the time of ordering the correct range will be set. If not then the Folomatic will be set for 4 - 20mA.

3 When using a 4 - 20mA control loop signal it is possible to select whether the actuator will 'stay put' or fail to the 4mA end of travel on loss of signal. Switch No. 1 on the Folomatic DIL switches to be selected 'on'.

Switches 2.3 and 2.4 on main board DIL switches

Both selected 'on' gives fail to the close end of travel.

Both selected 'off' gives fail to the open end of travel.

One switch 'off' and one 'on' will give 'stayput'.

4 Check that incoming control cables are connected to the following

a Current or voltage signal to 13(-ve) and 22(+ve), or alternatively.

b Customers potentiometer derived signal to 12, 22 wiper and 31.

5 With actuator set to local control run the valve to the nominated low signal end of travel.

6 Set input to required minimum value.

7 Locate the 'Zero' trimmer and adjust until the green indicator (if valve is at closed position) or red indicator (if valve is at open position) on the PCB just lights, either flashing or steady, clockwise movement of zero trimmer will illuminate the appropriate indicator.

8 Operate the valve to the opposite end of travel (high signal) using local control.

9 Set input signal to its required maximum level.

10 Locate the 'Span' trimmer and adjust until the red indicator (if valve is at the open position) or green indicator (if valve is at closed position) on the PCB just lights, either flashing or steady. Anticlockwise movement of the span trimmer will illuminate the appropriate indicator.

11 Set Local/Remote selector to 'Remote'. The actuator is available for Folomatic remote control to give full valve stroke with maximum input signal.

12 Deadband adjustment
If the actuator overshoots or responds unnecessarily to small changes in signal, increase the deadband by turning the deadband control clockwise. If greater sensitivity is required reduce deadband by turning anticlockwise. Check that hunting does not occur eg. when the actuator is moving in the increasing signal direction, it should stop when the balance between the input signal and the actuator feedback potentiometer is achieved without the green light flashing after the red lamp has extinguished. If hunting does occur, increase the deadband as necessary.

Motion inhibit timer adjustment

The red and green indicators on the PCB indicate a change of signal state:

Red = in the open position
Green = in the close position

If either indicator is flashing it indicates a change of signal state that is being prevented from operating the actuator for a predetermined length of time. This motion inhibit time is adjustable between 2 seconds and 40 seconds to suit site conditions. However it is advisable to reduce the delay time (anticlockwise adjustment of the trimmer) to minimum during the setting up procedure.

Setting the deep cover type Folomatic

The following instructions are for actuators with the Folomatic control unit fitted in a deep cover mounted on the terminal box.

When the Syncropak local/off/remote switch is set to 'local', the actuator functions like any other with open/stop/close manual control. The actuator should therefore be set to work initially under manual control in accordance with these instructions, the open and close torque and limit switches being set to suit the valve requirements. Only a 3-phase supply is required for this.

Electrical connections - 1400 Series only

For deep cover version fitted to 1600 Series apply to Rotork if alternative control mode is required.

1 Check whether valve is clockwise or anti-clockwise to close.

2 Determine whether valve is to close or open with low demand signal.

3 For clockwise to close valves, closing on low demand signal and anti-clockwise to close valves opening on low demand signal, the electrical connections between the Folomatic unit of the actuator terminals should be as follows:

Wire	37	38	39	14	23	32	4	5
Terminal	37	38	39	14	23	32	4	5

3 For clockwise to close valves, opening on low demand signal and anti-clockwise to close valves closing on low demand signal, the electrical connections between the Folomatic unit of the actuator terminals should be as follows:

Wire	37	38	39	14	23	32	4	5
Terminal	38	37	39	32	23	14	4	5

Check that the correct shunt and series range resistors are fitted as follows:

Current range

	Series range resistor	Shunt range resistor
0- 5mA	500mA fuse link	1000
0-10mA	500mA fuse link	500
0-20mA	500mA fuse link	250
0-50mA	500mA fuse link	100

Voltage range

0-5V	100mA fuse link	5K
0-10V	5K	5K
0-20V	15K	5K
0-50V	45K	5K

Potentiometer (0.5K - 10K)

100mA fuse link	Open circuit
-----------------	--------------

Setting Folomatic control unit

With the actuator and three phase supply of the correct voltage and rotation already wired but isolated, the procedure for setting the Folomatic Control unit is as follows:

1 Move valve to low signal end of travel.

2 Remove actuator indicator cover and set feedback potentiometer to the end of travel by rotating the cone of gears. Engage the appropriate gear in accordance with this instruction book.

3 Set 'local/off/remote' switch to 'local'.

4 Remove the Folomatic control unit using cover screws in jacking holes provided in accordance with this instruction book and lower carefully until supported by restraining strap. The unit can be temporarily bolted at one corner while the analog signal wires are connected as follows: current or voltage signal to F1- and F2+, potentiometer signal F1, F2 (wiper) and F3.

5 If the actuator is required to stay-put on loss of analog signal, link terminals F4 and F5.

6 Set input signal to required minimum valve.

7 Switch on three phase power supply. Adjust zero control potentiometer until green indicator just lights, either flashing or steady. Clockwise movement of zero control should turn on green and anti-clockwise red indicator.

Red signal indicator illuminates when there is an amplifier output to trigger movement in the direction corresponding to increasing signal.

Green signal indicator illuminates when there is an amplifier output to trigger movement in the direction corresponding to decreasing signal.

8 Operate valve to high signal end of travel using local control.

9 Increase input signal to maximum. Adjust span control potentiometer until red indicator just lights, either flashing or steady. Anti-clockwise movement of span control should turn on red, and clockwise green indicator.

10 Set 'local/off/remote' switch to 'remote'. The actuator is now set to give full valve stroke with maximum input signal span.

11 Deadband adjustment

If the actuator overshoots or responds unnecessarily to small changes in signal increase the deadband by turning deadband control clockwise. If greater sensitivity is required reduce deadband by turning anti-clockwise. Check that hunting does not occur, eg. when the actuator is moving in the increasing signal direction, it should stop when the balance between the input signal and the actuator feedback potentiometer is achieved without the green light flashing on after the red lamp has extinguished. If hunting does occur increase the deadband as necessary.

12 Motion inhibit adjustment*

The inhibit time can be minimised for setting purposes by adjusting motion inhibit time control anti-clockwise. The time should however be increased to the maximum, which will permit adequate control response in operation to give optimum service life and performance as soon as commissioning is complete.

13 Check that cable glands are tight and any unused entry sealed with threaded metal plug and sealing tape. If possible pour sealing compound into conduit entries from inside terminal compartment to perfect weather seal.

14 Replace Folomatic control unit and indicator cover with 'O' rings in place and screws tightened fully.

Fig A

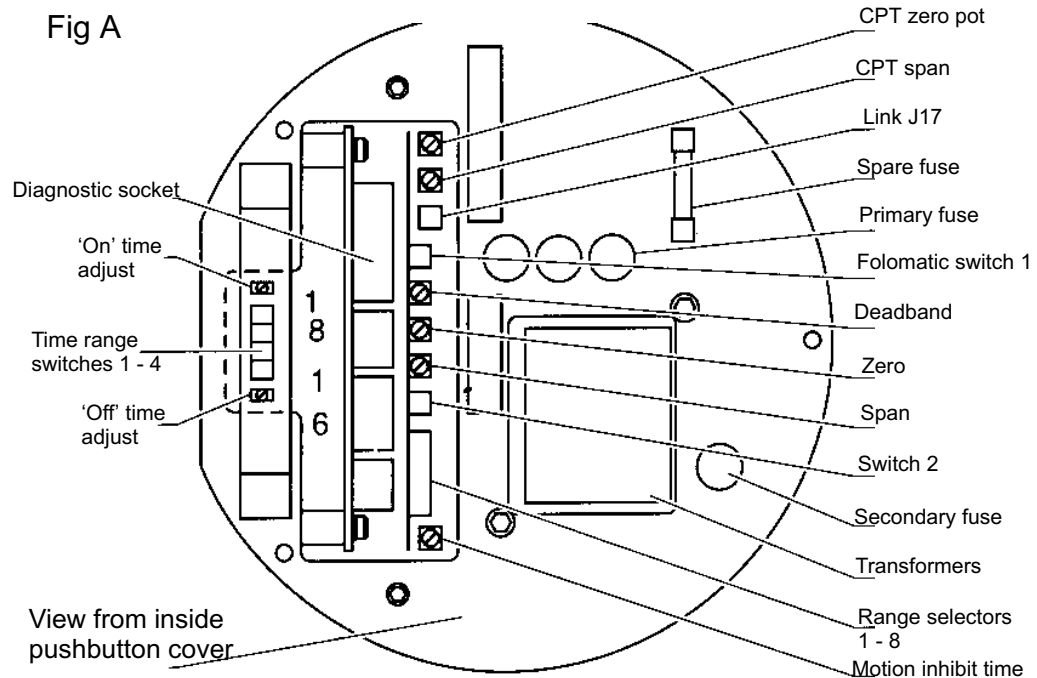

** Zero, span, deadband and motion inhibit controls are potentiometers with 27 turns for full travel incorporating a slipping clutch at each end of travel.*

5.2.6 Interrupter timer

When fitted, this can be used to lengthen the valve travel time in either one or both directions. It can also be used in conjunction with Add-on-Pak 1 intermediate limit switches to slow down the last portion of travel.

Setting instructions

A pair of potentiometers will be found behind the pushbutton cover. See fig.A. They are marked 'on' and 'off' and are used to set the on/off times of operation.

After removing the cover, rotate the potentiometers fully anti-clockwise. This will give the shortest 'on' and 'off' times

Rotating either potentiometer clockwise will increase the time (on or off) and a convenient interrupting sequence can be set so that there are no unnecessary frequent starts demanded from the actuator. Where the actuator is to be used in '2-speed' mode, the appropriate Add-on-Pak 1 switch will need to be set to break at the start of the interruption sequence. See section 5.2.1 and wiring diagram.

5.2.7 'PA' failsafe actuators

Refer to Rotork publication E271E (AE5/8) for coupling details.

6 Electrical start-up

Check that limit switches have been set; see section 5.

All actuators (except Syncropak 1600 series)

6.1 Checking rotation

If valve stem is not visible, remove stem cover to observe direction of output rotation.

Engage 'hand' and wind handwheel until valve is well away from end position.

6.2 Syncropak 1400 series actuators

Switch on power supply and check that indicator lamp is on.

Remove padlock (if fitted) and turn selector switch to 'local'.

Turn pushbutton to 'open' and check output rotation.

If phase rotation is correct valve should open. If valve starts closing press pushbutton immediately to stop actuator and avoid valve damage or jamming.

If your actuator has been fitted with a Rotork Phase Rotation Discriminator to avoid such accidental damage, it will not start with incorrect phase rotation or with one phase dead.

Correct phase rotation as follows:
3 phase actuators
Exchange any two of three phase supply leads at power terminals; see section 4.

Single phase actuators
Exchange connections to terminals 2 and 3.

If valve runs open, run valve to full travel in 'open' and 'close' directions.

If actuator stops prematurely it may be due to too low a torque setting. Increase as necessary; see section 5.

For valve requiring precisely controlled position limit, check that valve maker's mark on valve is reached. If it is not this is due to incorrectly set limit switches; see section 5.

Replace stem cover using suitable sealing tape or compound and return selector switch to appropriate position. Padlock if required.

6.3 Syncropak 1600 Series actuators

Syncropak 1600 Series incorporates automatic phase rotation by Synchrophase.

This circuit corrects motor rotation, by selecting the appropriate motor contactor irrespective of customer's supply phase rotation.

6.4 Syncroset actuators

Switch on power supply. If there are no pushbuttons within sight of the actuator arrange telephone link between control station and the observer at the actuator.

Press 'open' button.

If connections are correct valve should open.

If the valve starts closing stop immediately. If there is no local stop, engage hand immediately and hold in hand drive until remote stop button is operated.

Correct phase rotation as follows:

3 phase actuators
Exchange any two of three phase supply leads at power terminals.

DC actuators
Exchange connections at terminals 1 and 2.

Single phase actuators
Exchange connections at power terminals 2 and 3.

6.4.1

If valve opens, run valve to full travel in 'open' and 'close' directions.

If the actuator stops prematurely it may be due to too low a torque setting. Increase as necessary; see section 5.

For valves requiring precisely controlled position limit, check that valve marker's mark on valve is reached. If it is not, this is due to incorrectly set limit switches; see section 5.

Replace stem cover using suitable sealing tape or compound.

7 Trouble shooting

7.1 Syncropak actuators

The starter cover is bonded by the Rotork quality control seal, and should only be removed if electrical tests made at the terminal box indicate an internal fault.

Check that the clutch lever is not padlocked in hand before trouble shooting unless you wish to run the motor without driving the valve.

Actuator fails to start on remote control

The packaged controls of Rotork syncropak make fault location simple.

Set selector switch to local and switch on power supply, when the indicator lamp should light. If the actuator starts correctly in each direction when the pushbutton is turned, the fault can only be in the remote control circuit.

Actuator fails to start on local control

Set selector switch to local and switch power on. If actuator fails to start remove terminal cover and check, if 3 phase, that all three phase terminals are live, with the correct voltage as indicated on the nameplate and that 110-120 volts is available at terminals 4 and 5 (1400 series) or 24V DC (1600 series).

If the motor is very hot, thermostat will have tripped, which will disconnect control supply between terminals 40 and 4. If there is no voltage between terminals 4 and 5, you may break quality control seal and remove starter cover.

Check transformer fuses and replace if necessary with spare provided.

Note: 1400 series only: The diagram number on wiring code card inside cover will indicate if Phase Rotation Discriminator is fitted, in which case actuator will not start with incorrect rotation. Exchange any two phases and try again.

7.3 All actuators

Valve jammed

Likely causes:

1 Reversed phase rotation/incorrect rotation. (Not applicable to Syncropak 1600 Series). See section 6.

2 Limit switches not set correctly; see section 5.

To free valve jammed open Manual operation of the handwheel utilizing the hammerblow mechanism should be sufficient to unjam the valve.

To free valve jammed shut Loosen actuator mounting bolts evenly to release thrust. Free the valve by hand and re-tighten mounting bolts.

Valve not seating correctly

Likely causes:

1 The 'close' torque/limit selector has been set at 'limit'. Reset to 'torque'.

2 The 'close' torque setting is too low. Increase as necessary; see section 5.

Actuator runs without driving valve

Likely causes:

1 Clutch lever padlocked in 'hand'.

2 Drive bush not correctly locked in place; see section 2.

8 Lubrication and maintenance

8.1 Oil

Unless specially ordered for extreme climatic conditions Rotork actuators are despatched with gearboxes filled with SAE 80 EP oil, suitable for ambient temperatures ranging from -22F/-30C to 160F/70C.

Oil capacities

7A, 11A, 13A: 0.6 litre

14A, 16A: 1.4 litre

30A: 2.0 litre

40A: 3.0 litre

70A, 90A, 91AR, 95A: 4.5 litre

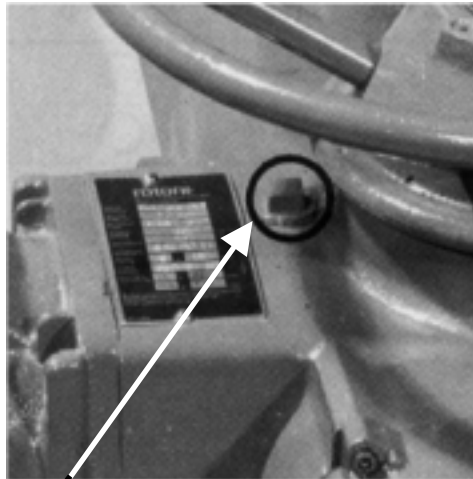

Oil fill/drain plugs

8.2 Oil fill/drain plugs

The use of the plugs provided is determined by the mounting position on the valve.

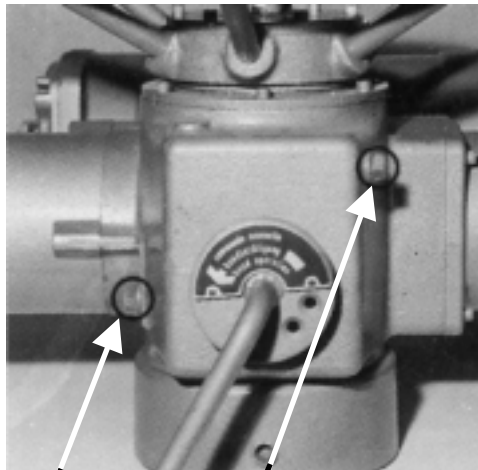

Oil fill/drain plugs

8.3 Maintenance

After six month's operation tighten mounting bolts.

If your Rotork actuator has been properly installed and sealed, normal valve operation produces little wear and tear, so no routine maintenance is recommended beyond the lubrication of valve stems and nuts. If the motorized valve is rarely operated, a routine operating schedule should be set up.

Appendix 1

Folomatic PCB DIL switch settings voltage or current ranges

Range	SW1	SW2	SW3	SW4	SW5	SW6	SW7	SW8
0-5mA	<input type="checkbox"/>	<input type="checkbox"/>	<input type="checkbox"/>	<input checked="" type="checkbox"/>	<input type="checkbox"/>	<input type="checkbox"/>	<input type="checkbox"/>	<input type="checkbox"/>
0-10mA	<input type="checkbox"/>	<input type="checkbox"/>	<input type="checkbox"/>	<input checked="" type="checkbox"/>	<input type="checkbox"/>	<input type="checkbox"/>	<input checked="" type="checkbox"/>	<input type="checkbox"/>
0-20mA	<input type="checkbox"/>	<input type="checkbox"/>	<input type="checkbox"/>	<input checked="" type="checkbox"/>	<input type="checkbox"/>	<input checked="" type="checkbox"/>	<input checked="" type="checkbox"/>	<input type="checkbox"/>
4-20mA	<input checked="" type="checkbox"/>	<input type="checkbox"/>	<input type="checkbox"/>	<input checked="" type="checkbox"/>	<input type="checkbox"/>	<input checked="" type="checkbox"/>	<input checked="" type="checkbox"/>	<input type="checkbox"/>
0-50mA	<input type="checkbox"/>	<input type="checkbox"/>	<input type="checkbox"/>	<input checked="" type="checkbox"/>	<input checked="" type="checkbox"/>	<input checked="" type="checkbox"/>	<input checked="" type="checkbox"/>	<input type="checkbox"/>
0-5V	<input type="checkbox"/>	<input type="checkbox"/>	<input type="checkbox"/>	<input type="checkbox"/>	<input type="checkbox"/>	<input type="checkbox"/>	<input type="checkbox"/>	<input type="checkbox"/>
0-10V	<input type="checkbox"/>	<input type="checkbox"/>	<input checked="" type="checkbox"/>	<input type="checkbox"/>	<input type="checkbox"/>	<input type="checkbox"/>	<input type="checkbox"/>	<input type="checkbox"/>
0-20V	<input type="checkbox"/>	<input checked="" type="checkbox"/>	<input type="checkbox"/>	<input type="checkbox"/>	<input type="checkbox"/>	<input type="checkbox"/>	<input type="checkbox"/>	<input type="checkbox"/>

- Off
- On
- Off/On

SW1 Off - actuator runs to low signal end of travel on loss of signal

SW1 On - actuator responds on loss of signal according to priority setting of main PCB switches

rotork

Rotork Controls Ltd.
Brassmill Lane
Bath BA1 3JQ

mail@rotork.co.uk