



Keeping the World Flowing
for Future Generations



IW Quarter-turn Gearbox Series Sizes 14 - 17

The IW14 and above large worm quadrant operators have been designed to withstand twice their torque to accommodate actuator stall torques. Due to their large size and the logistics involved these gearboxes were designed for low or no maintenance.

The design also takes care of installation with the ability to have the input from either side of the gearbox and caters also for both clock and anti-clock valve actuation. All inputs and outputs can be supplied to ISO standards and can also be adapted to any other standards or variations.

Application

The IW series gearboxes are quarter-turn operators intended for the operation of quarter-turn Ball, Butterfly and Plug valves and any other quarter-turn device requiring a reduction for its operation. They are used mainly for motorised applications but can also be used manually or with power tools.

Features

- Designed with a minimum safety factor twice the maximum output torque to cater for stall torques and site variations
- High quality tapered roller bearings are used to support the worm screw, with a pre-load adjusted one by one with ground spacers
- The worm screw is in alloy steel 18 NiCrMo5Pb, casehardened and ground to give a minimum friction with the quadrant creating a high efficiency and a larger number of operations unlike the traditional worm screws

IW Quarter-turn

Sizes 14 - 17 Ductile Iron Housing Gearboxes

- Tighter and controlled tolerances obtained through grinding give a negligible backlash between the worm and the quadrant resulting in a better accuracy in the movements and reduced vibrations during travel or partial open movement
- The housing is a much stronger ductile iron
- All the input reducer gears are in carbon steel with the pinions in alloy steel
- The Planetary gears use planet carrier machined from solid carbon steel
- Grease filled for life and fully sealed with o-rings
- Comprehensive gear ratio with combination spur and planetary gear reducers
- Adjustable mechanical stops at 0° and 90° +/- 5°

Environmental specification

- IP67 enclosure
- -4 to +176 °F

Options

- IP68 enclosure
- AWWA application
- High and low temperature
- Padlockable kits
- Limit switches
- All types of environments
- Flexible extensions

IW Quarter-turn Sizes 14 - 17 Ductile Iron Housing Gearboxes



Material Specification for Rotork IW Series Quarter-turn Gearbox Series Sizes 14 - 17

No.	Description	Material	Notes
1	Body	Ductile Iron	EN-GJS-400-18
2	Quadrant	Ductile Iron	EN-GJS-500-7
3	Worm Screw	Alloy Steel	18 NiCrMo 5 Pb
4	Position Indicator	Steel	S275JR
5	Cover Plate	Ductile Iron	EN-GJS-400-12
6	Tapered Roller Bearings	Carbon Steel	-
7	Radial Ball Bearings	Carbon Steel	-
8	O-ring Seal	NBR	-
9	Stop Bolt	Steel	GR B7
10	Spur Gear	Carbon Steel	C45
11	Spur Body	Ductile Iron	EN-GJS-400-12
12	Input Shaft	Alloy Steel	39 NiCrMo3
13	Spur Body cover	Ductile Iron	EN-GJS-400-12
14	Fasteners	Carbon Steel	-

Note: Because of the company's policy of continuous improvement, Rotork reserves the right to change specification details without prior notice.

IW Quarter-turn Sizes 14 - 17 Ductile Iron Housing Gearboxes

Gearbox IW Series Sizes 14 - 17

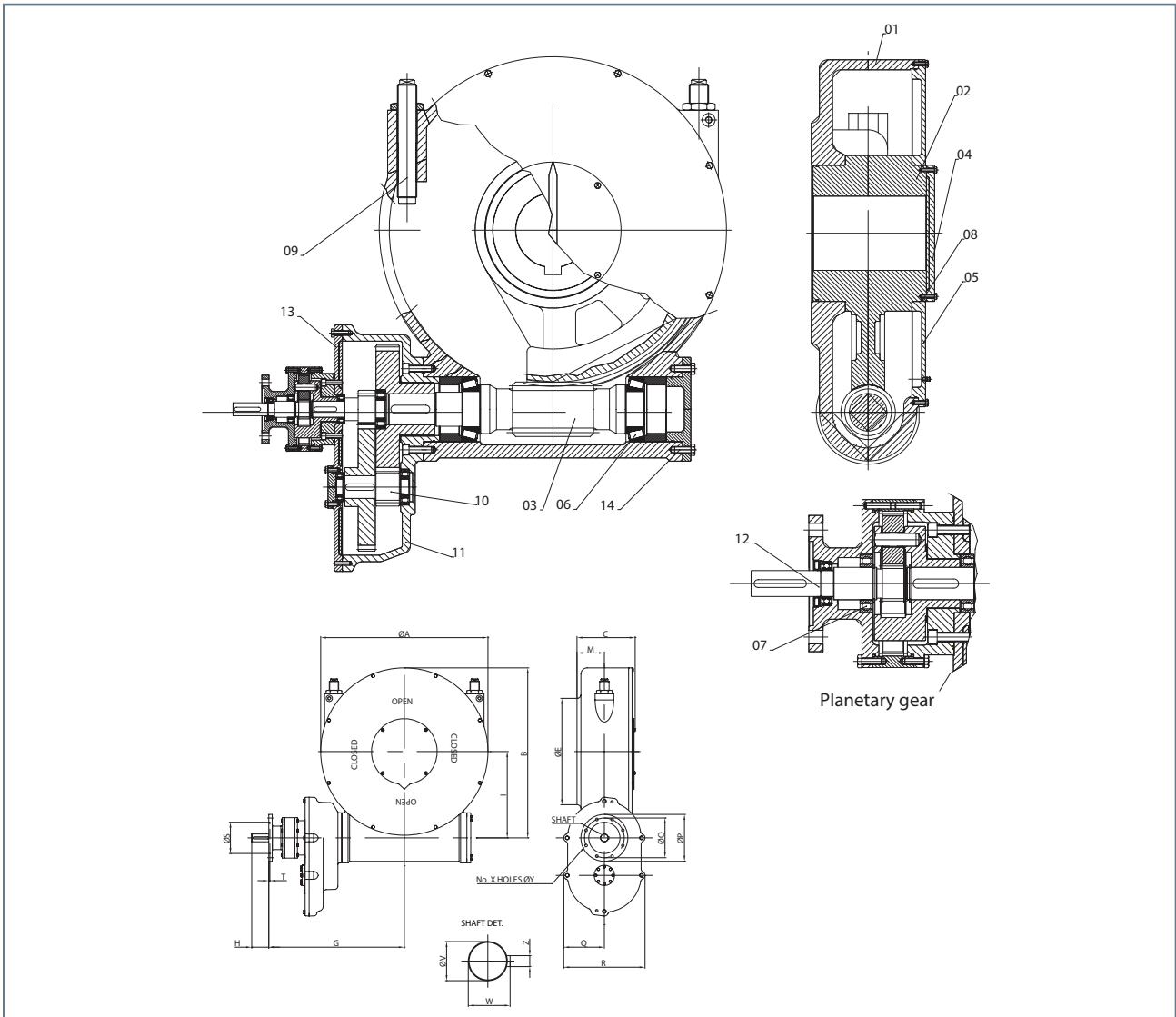

Gearbox Size	Valve Flange	A	B	C	E	G	H	I	M	O	P	Q	R	S	T	V	W	X	Y	Z	Weight (lbs)
IW14FA14	FA48-FA60	42.126	42.795	13.976	26.772	34.016	2.165	20.551	5.906	5.512	6.890	10.236	20.472	3.937	0.197	1.181	1.311	4	0.669	0.315	4189
IW14FA16	FA48-FA60	42.126	42.795	13.976	26.772	34.016	3.504	20.551	5.906	6.496	8.268	10.236	20.472	5.118	0.236	1.575	1.705	4	0.827	0.472	4189
IW14FA25	FA48-FA60	42.126	42.795	13.976	26.772	34.016	4.291	20.551	5.906	10.000	11.811	10.236	20.472	7.874	0.236	1.969	2.142	8	0.669	0.551	4189
IW14FA30	FA48-FA60	42.126	42.795	13.976	26.772	34.016	4.291	20.551	5.906	11.732	13.780	10.236	20.472	8.268	0.236	1.969	2.142	8	0.827	0.551	4189
IW15FA14	FA48-FA60	42.126	42.795	13.976	26.772	34.016	2.165	20.551	5.906	5.512	6.890	10.236	20.472	3.937	0.197	1.181	1.311	4	0.669	0.315	4365
IW15FA16	FA48-FA60	42.126	42.795	13.976	26.772	34.016	3.504	20.551	5.906	6.496	8.268	10.236	20.472	5.118	0.236	1.575	1.705	4	0.827	0.472	4365
IW15FA25	FA48-FA60	42.126	42.795	13.976	26.772	34.016	4.291	20.551	5.906	10.000	11.811	10.236	20.472	7.874	0.236	1.969	2.142	8	0.669	0.551	4365
IW15FA30	FA48-FA60	42.126	42.795	13.976	26.772	34.016	4.291	20.551	5.906	11.732	13.780	10.236	20.472	8.268	0.236	1.969	2.142	8	0.827	0.551	4365
IW16FA14	FA60 or larger	49.409	50.709	16.575	29.528	42.598	2.165	25.984	7.283	5.512	6.890	12.008	24.016	3.937	0.197	1.181	1.311	4	0.669	0.315	6790
IW16FA16	FA60 or larger	49.409	50.709	16.575	29.528	42.598	3.504	25.984	7.283	6.496	8.268	12.008	24.016	5.118	0.236	1.575	1.705	4	0.827	0.472	6790
IW16FA25	FA60 or larger	49.409	50.709	16.575	29.528	42.598	4.291	25.984	7.283	10.000	11.811	12.008	24.016	7.874	0.236	1.969	2.142	8	0.669	0.551	6790
IW16FA30	FA60 or larger	49.409	50.709	16.575	29.528	42.598	4.291	25.984	7.283	11.732	13.780	12.008	24.016	8.268	0.236	1.969	2.142	8	0.827	0.551	6790
IW17FA14	FA60 or larger	49.409	50.709	16.575	29.528	42.598	2.165	25.984	7.283	5.512	6.890	12.008	24.016	3.937	0.197	1.181	1.311	4	0.669	0.315	7011
IW17FA16	FA60 or larger	49.409	50.709	16.575	29.528	42.598	3.504	25.984	7.283	6.496	8.268	12.008	24.016	5.118	0.236	1.575	1.705	4	0.827	0.472	7011
IW17FA25	FA60 or larger	49.409	50.709	16.575	29.528	42.598	4.291	25.984	7.283	10.000	11.811	12.008	24.016	7.874	0.236	1.969	2.142	8	0.669	0.551	7011
IW17FA30	FA60 or larger	49.409	50.709	16.575	29.528	42.598	4.291	25.984	7.283	11.732	13.780	12.008	24.016	8.268	0.236	1.969	2.142	8	0.827	0.551	7011

All dimensions in inches. Contents may change without previous notice.

Gearbox Sizing Data

Gearbox Model	Ratios	Mechanical Advantage ±10%*	Max. Input Torque (lbf-in)	Max. Output Torque 7000 Cycles (lbf-in)	Max. Output Torque 1000 Cycles (lbf-in)	Output Flange	Stem diam. (In)		Stem Height (In)	Approx. Weight Lb
							Min.	Max.		
IW14R1	1280 to 320	427 to 107	6222 to 24818	2212675	2655210	FA48-FA60	8.661	13.780	13.976	4850.120
IW14R2	6144 to 1536	1949 to 487	1362 to 5452	2212675	2655210	FA48-FA60	8.661	13.780	13.976	4850.120
IW14R3	6400 to 1600	2030 to 508	1308 to 5227	2212675	2655210	FA48-FA60	8.661	13.780	13.976	4850.120
IW15R1	1088 to 272	383 to 96	8320 to 33190	2655210	3186252	FA48-FA60	8.661	13.780	13.976	4850.120
IW15R2	5222 to 1306	1747 to 437	1824 to 7291	2655210	3186252	FA48-FA60	8.661	13.780	13.976	5069.200
IW15R3	5440 to 1360	1819 to 455	1752 to 7003	2655210	3186252	FA48-FA60	8.661	13.780	13.976	5069.200
IW16R1	992 to 248	358 to 90	14834 to 59008	4425350	5310420	FA60 or larger	9.055	14.961	16.142	6832.400
IW16R2	15942 to 1190	5194 to 408	1022 to 13016	4425350	5310420	FA60 or larger	9.055	14.961	16.142	6832.400
IW17R1	880 to 220	326 to 81	23074 to 92880	6638025	7523095	FA60 or larger	9.055	14.961	16.142	7052.800
IW17R2	14142 to 1056	4723 to 373	1593 to 20169	6638025	7523095	FA60 or larger	9.055	14.961	16.142	7052.800

*The published M.A. is achieved after a few cycles. More ratios are available.

A full listing of the Rotork sales and service network is available on our website.

www.rotork.com

Corporate Headquarters
Rotork plc

tel +44 (0)1225 733200
email mail@rotork.com

Rotork Gears UK
9 Brown Lane West
Holbeck, Leeds LS12 6BH
England

tel +44 (0)113 256 7922
email sales@rotorkgears.com



Electric Actuators and Control Systems
Fluid Power Actuators and Control Systems
Gearboxes and Gear Operators
Precision Control and Indication
Projects, Services and Retrofit