



Keeping the World Flowing  
for Future Generations



Skilmatic **SI** intelligent actuators offer a unique combination of the renowned features of Rotork actuation, such as the double-sealing system and non-intrusive infrared commissioning capability, with the benefits of control and safety from Skilmatic range.

The **SI-2.1Q** range is compact and robust, electrically operated failsafe, spring-return, quarter-turn actuators. Designed to provide a 90 degree travel for two-position, ESD or modulating applications. The actuators are suitable for all types of quarter-turn valves and are supplied with a mounting flange to ISO 5211.

The **SI-2.1Q** is watertight and dust-tight up to IP67 / NEMA 6 with the option of IP68 and includes the Rotork double-seal system with separated termination and cable gland compartment. The actuators are also available certified explosionproof for hazardous area gas group **IIB** and **IIC** applications.

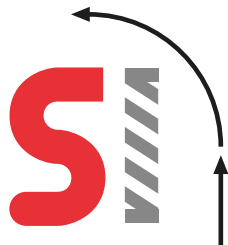

## Skilmatic SI-2.1Q

Spring-Return Electric Quarter-Turn Actuator  
(380 to 4407 Nm)

### Features

- Self-contained electrically operated actuator with internal low pressure electro hydraulic control module
- Spring-return, failsafe or lock in position
- Spring-return speed options – single or dual valve combinations
- Single-phase, three-phase and DC power supply
- Watertight and explosionproof for gas group IIB & IIC
- Double-sealed control module – with separate terminal compartment
- Non-intrusive commissioning and configuration setting tool
- Local LCD dual screen display – for position indication, internal pressure and fault diagnostics
- Local controls – lockable Local/Stop/Remote selector switch with local Open/Closed switch
- Modulating control – 4-20 mA input and output with a resolution < 0.25 %
- Digital control – two position and emergency shutdown options for functional safety instrumented systems
- Output relays for monitoring, fault alarms and Open/Closed limits
- Optional Fieldbus communications
- Built in datalogger – Recording events, trends and alarms
- Partial stroking capabilities for ESD applications activated remotely or locally via the setting tool
- Functional safety – SIL certified

## Skilmatic SI-2.1Q

Consisting of a self-contained electro-hydraulic control module and Scotch yoke spring-return drive, the actuators combine the simplicity of electrical operation, with the precision of hydraulic control, and reliability of spring-powered failsafe action. The spring-return mechanism provides the most reliable means of positioning a valve to the safe condition and can be provided as failsafe close, open or lock in last position on power or signal failure. The actuators are available as spring-return clockwise or anticlockwise, with end of spring torque from 380 Nm (3,363 lbf.in) to 4,407 Nm (39,002 lbf.in).

The actuators can be programmed with the *Bluetooth®* wireless setting tool to accept an analogue or digital input, with ESD and partial stroking or network cards options. A wide range of functions can also be selected through the setting tool such as zero and span limits, dead band, hysteresis, interrupter timer, ESD options, partial stroke testing and alarms.

The actuator is provided with a built in datalogger to record the configuration settings and the last 1,024 events with 32 bits of status for each event. The data can be downloaded via the Rotork *Bluetooth®* Setting Tool *Pro*. Optional internal fieldbus communication boards are also available for the Rotork *Pakscan™*, *DeviceNet®*, *Profibus®*, *Foundation Fieldbus®* and *Modbus®* digital control systems.

Specifically designed for on/off duties particularly where failsafe ESD action is required, lockable local controls are provided as standard and on safety critical applications the local selection can be overridden depending on the actuator configuration. The actuator can also be configured for ESD manual reset. Electro-mechanical ends of stroke limit switches are also provided.

Operating from a standard single-phase, three-phase or 24 VDC supply the actuators are also ideal for modulating control applications, the control module provides a pulsed hydraulic signal to accurately position the spring-opposed cylinder. Resulting in accurately positioning a valve with a resolution better than 0.25 of a degree. A manual override gearbox or hydraulic hand pump is available on all sizes. (gearboxes available up to SI-2.1-Q80 only).

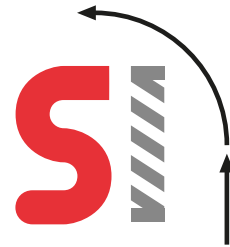

## SI-2.1-Q60 to Q80 Dimensions and Mounting Details

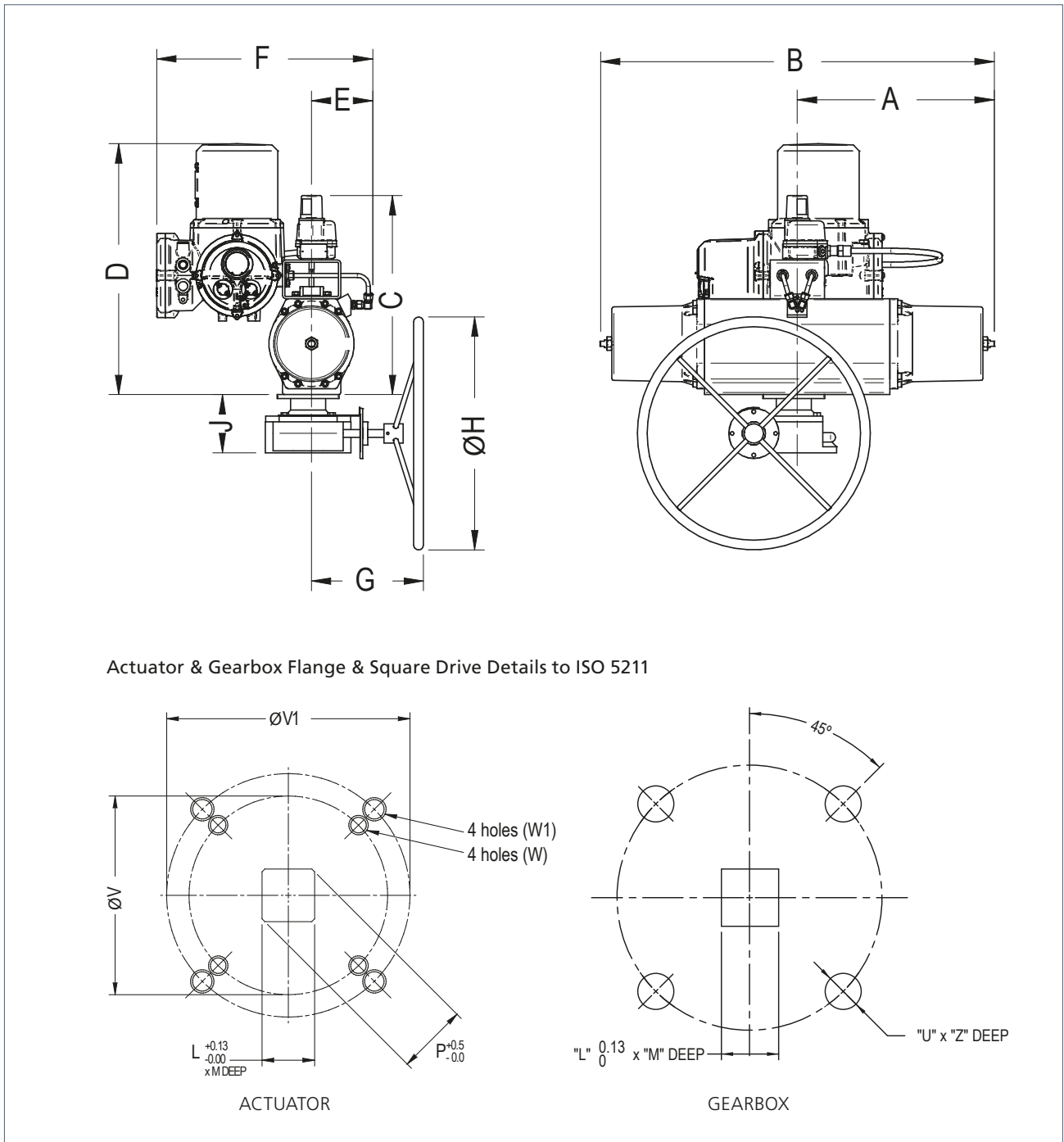

CODE	A	B	C	D	E	F	F*	G	H	J	L	M	P	ØV	ØV1	W	W1	U X Z	Weight (kg)
<b>Q61/Q60</b>	285	570	382	534	133	525	616	257	600	134	27	37	37	102	125	M10 X 17	M12 X 21	M12 X 16	62
<b>Q70</b>	510	655	495	647	157	564	657	297	600	149	36	64	49	140	N/A	M16 X 25	N/A	M16 X 18	98
<b>Q80</b>	510	1020	494	647	157	556	641	415	600	175	46	64	61	125	165	M12 X 25	M20 X 32	M20 X 18	127

For 3-Phase units use F\* instead of F.  
 Q70 have additional mounting hole pattern: 170 x 110 mm, 4 x M16 x 25 deep.  
 Q80 have additional mounting hole pattern: 234.7 x 97.2 mm, 4 x M16 x 25 deep.  
 Manual override gearbox is optional.

All dimensions in mm.

## SI-2.1-Q110 to Q112 Dimensions and Mounting Details

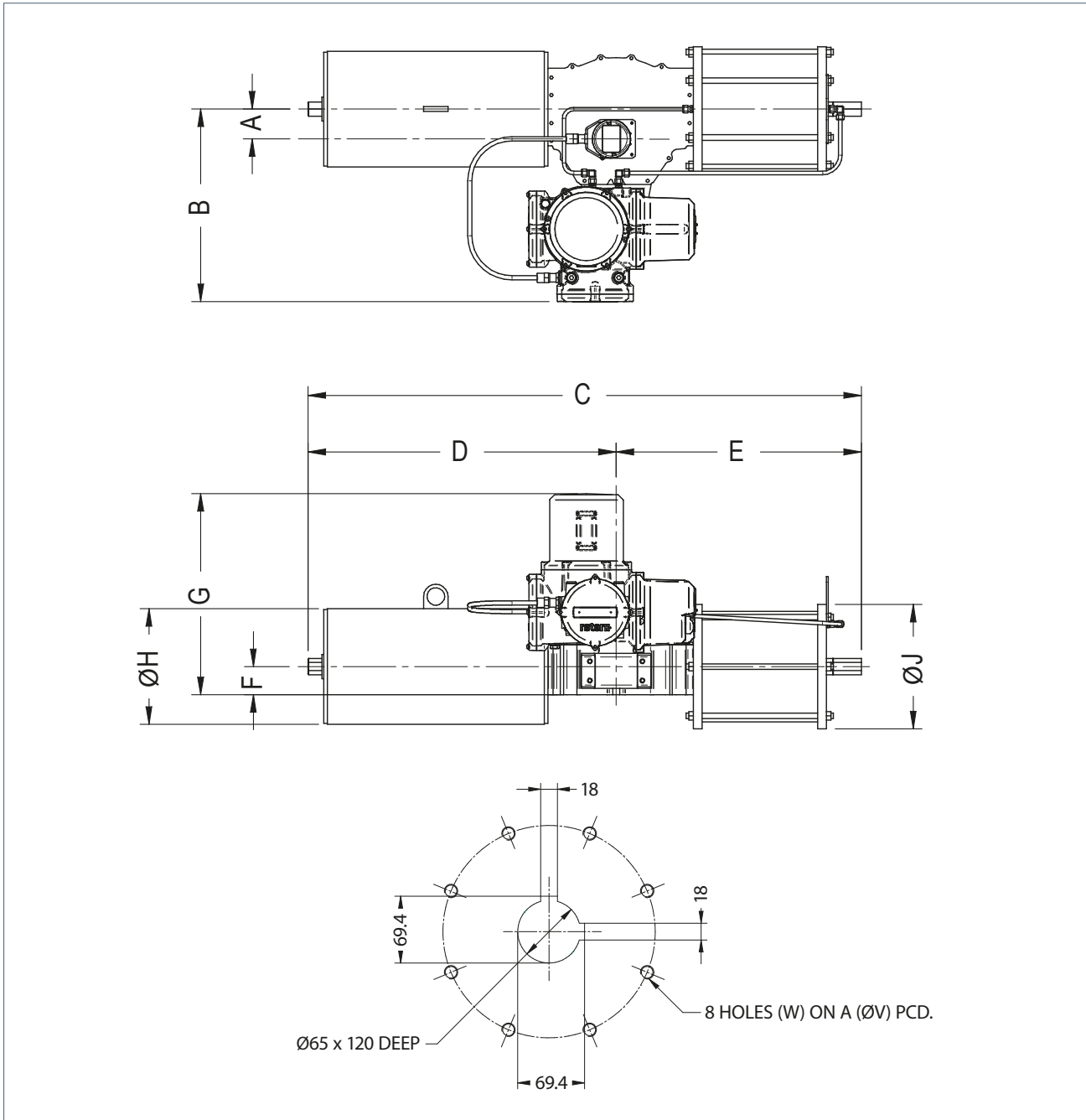

CODE	A	B	B*	C	D	E	F	G	H	J	ØV	W	Weight (kg)
Q110	85	550	635	1580	880	700	165	569	330	355	254	M16 X 15	350
Q111	85	550	635	1615	895	720	163	569	325	415	254	M16X15	400
Q112	85	550	635	1715	995	720	205	569	410	415	254	M16X15	500

For 3-Phase units use B\* instead of B.  
Optional Manual override hydraulic hand pump is not shown.

All dimensions in mm.

# Ordering Code

## Ordering Code Example

SI-2.1-Q80 - 0 0 2 - 1 0 - 0 0 - A A

### Failure Mode

- 0 = Failsafe on loss of power supply (in direction of spring) (note 4.2)
- 1 = Fail in Position on loss of power supply (note 4.3)

### Spring-return Speed & ESD Options

- 0 = Speed A – Single internal solenoid (note 4.2)
- 1 = Speed B – Dual internal solenoid (note 4.2 & 4.4)
- 2 = Speed C – Single internal & external solenoid (note 2.1 & 4.2)
- 3 = Speed D – Slow acting internal solenoid – Consult sales office
- 4 = Speed E – Single internal and single external solenoid with increased flow (note 2.1 & 4.2)
- 5 = Speed F – Single internal and dual external solenoid with increased flow (note 2.1 & 4.2)
- 6 = Speed A – Hardwired single internal ESD solenoid (note 3.4 & 4.3)
- 7 = Speed C – Hardwired single internal & external solenoid (note 2.1 & 4.3)

### Supply Voltage

- 0 = Single-phase 115 VAC ± 10% 50/60 Hz
- 1 = Single-phase 230 VAC ± 10% 50/60 Hz
- 2 = 24 VDC ± 10%
- 3 = Three-phase 380-480 VAC ± 10% 50/60 Hz

### Control

- 0 = Standard digital control (Open / Closed / partial stroke)
- 1 = Analogue control 4-20 mA or 0-10 VDC (note 1.2 & 4.1)
- 2 = *Pakscan* (note 4.1)
- 3 = *Pakscan* – analogue input (note 4.1)
- 4 = Modbus single channel (note 4.1)
- 5 = Modbus dual channel (note 4.1)
- 6 = Profibus dual channel (note 4.1)
- 7 = DeviceNet (note 4.1)
- 8 = Foundation Fieldbus (note 4.1)
- 9 = Profibus single channel (note 4.1)

### Certifications

- 0 = WT – Watertight IP67
- 1 = ATEX – European – Hazardous area Gas group IIB (IP67)
- 1C = ATEX – European – Hazardous area Gas group IIC (IP67) (note 2.2)
- 2 = IEC Ex – International – Hazardous area Gas group IIB (IP67)
- 2C = IEC Ex – International – Hazardous area Gas group IIC (IP67) (note 2.2)
- 3 = FM – US – Hazardous area Gas group IIB (IP67)
- 3C = FM – US – Hazardous area Gas group IIC (IP67) (note 2.2)
- 4 = CSA – Canada – Hazardous area Gas group IIB (IP67)
- 4C = CSA – Canada – Hazardous area Gas group IIC (IP67) (note 2.2)
- 5 = EAC – Russia TR TS Hazardous area Gas Group IIB
- 5C = EAC – Russia TR TS Hazardous area Gas Group IIC (IP67) (note 2.2)
- 8 = CCC – China – Hazardous area Gas Group IIB (IP67)
- 8C = CCC – China – Hazardous area Gas Group IIC (IP67) (note 2.2)
- 9 = UKEX – UK – Hazardous area Gas Group IIB (IP67)
- 9C = UKEX – UK – Hazardous area Gas Group IIC (IP67) (note 2.2)

### Cable Entries

- 0 = M25 x 1.5P
- 1 = M20 x 1.5P
- 2 = ½" NPT
- 3 = ¾" NPT
- 4 = 1" NPT

### Hydraulic Fluid/Operating Temperature

- 0 = Mineral fluid –10 to +65 °C (note 3.2)
- 3 = Food grade fluid –10 to +65 °C (note 3.2)
- 4 = Silicone fluid –30 to +65 °C (note 2.2)
- 5 = Silicone fluid / Low temperature seals –40 to +65 °C (note 2.2)

### Mounting

- A = Vertical stem above valve
- B = Vertical stem below-valve
- C1 = Valve stem & pipeline horizontal
- C2 = Valve stem horizontal, pipeline vertical
- D = Vertical stem above valve with valve mounting kit
- E = Valve stem vertical below valve with valve mounting kit
- F1 = Valve stem & pipeline horizontal with valve mounting kit
- F2 = Valve stem horizontal, pipeline vertical with valve mounting kit

### Accessories

- A = None
- B = Manual override hydraulic hand pump
- C = Manual override (Gearbox)
- D = WT – Watertight IP68 - 7m for 72 hours (note 2.1)
- F = Two additional volt free SPDT limit switches (four total)
- G = Hardware ESD configuration (Failsafe actuators only) (note 4.2, 4.3, 4.4)
- H = All cable entries plugged
- J = Viton seals
- K = Paint colour change to standard specification
- L1 = Coastal Paint & Exd IIC applications (2 pack Epoxy 150 to 200 microns)
- L2 = Offshore Paint, watertight & Exd IIB applications (2 pack Epoxy to 250 to 350 microns)
- M = Proximity limit switches replacing standard V3 micro switches
- N = Flow control valve – to adjust and increase the stroke speed in the spring direction
- O = Optional low power external solenoid valve option for 'Spring-Return Speed & ESD Options' code 2 or 7 – consult sales office
- T = Remote mounted EH power module (Max distance 5m from actuator drive)

# Ordering Code

## Notes:

### General

- 1.1 Select one option from each section except accessories with multiple options.
- 1.2 All actuators supplied with 4-20mA input/output as standard.

### Certification

- 2.1 All actuators are watertight to IP67, the option of IP68 is available except for external solenoid option. (Spring-return speed and ESD options – code 2 & 7).
- 2.2 Explosionproof actuators for gas group IIC, available only for temperatures -20 to +65 °C. (Certifications – code 1C, 2C, 3C, 4C, 5C, 6C, 8C, 9C).

### Operating Speed

- 3.1 Stroke speed is typical with no load at 20 °C. Speed can vary +/-15% (or +/- 1s, whichever is greater) at 20 °C.
- 3.2 Spring stroke speeds with mineral and food grade fluid are effected by ambient temperatures below 0 °C. Speed can change by up to 50%. Select silicone fluid where this is not acceptable.
- 3.3 Speed C, E or F not available for FM or CSA certified actuators. Consult sales office.
- 3.4 Spring return speed option '6'. ESD command – speed A. Standard close command – Speed A +10% nominal.

## Functional Safety

- 4.1 Analogue control, local controls, partial stroking and communication circuits are not part of the functional safety circuit.
- 4.2 Functional safety applications (SIL) – Failsafe on loss of power supply or ESD. (Spring-return speed and ESD Options – code 0, 1, 2 or 3 and accessories – code G).
- 4.3 Functional safety applications (SIL) – Fail in last position on loss of power supply, failsafe on loss of 24 VDC ESD signal. ESD signal powers solenoid directly. Consult factory for voltage and power requirements. (Spring-return speed and ESD options – Ccode 6 or 7 and accessories – code G).
- 4.4 Functional safety applications (SIL) – If dual solenoid valves are for redundancy then refer to single solenoid speed 'A' (spring return speed and ESD options – code 1).

# Performance Data

Code	Torque Nm (lbf.in)							Possible Max Hydraulic @12 bar relief valve setting	Hydraulic Speed (+/- 15%)	Stroke Speed (seconds)				
	BTO	RTO	ETO	BTC	RTC	ETC	Spring Return Speed (+/- 15%) (note 3.1, 3.2, 3.3)							
	Speed A	Speed B	Speed C	Speed E	Speed F									
Clockwise	SI-2.1-Q60	1007 (8903)	395 (3492)	563 (4978)	500 (4421)	260 (2298)	380 (3359)	1290 (11406)	14	14	10	6	3	2
	SI-2.1-Q61	907 (8019)	326 (2882)	434 (3837)	630 (5570)	340 (3006)	480 (4244)	1188 (10504)	14	13	9	6	3	2
	SI-2.1-Q70	2003 (17710)	813 (7188)	1124 (9938)	1160 (10256)	570 (5039)	800 (7073)	2565 (22679)	27	27	18	8	5	n/a
	SI-2.1-Q80	4218 (37295)	1625 (14368)	2278 (20142)	2350 (20778)	1150 (10168)	1605 (14191)	5399 (47738)	52	54	37	17	10	6
	SI-2.1-Q110	4671 (41301)	2303 (20363)	3122 (27605)	3819 (33767)	1825 (16136)	2380 (21044)	6230 (55086)	73	75	52	12	n/a	7
	SI-2.1-Q111	6840 (60483)	3512 (31049)	4995 (44168)	5031 (44487)	2445 (21615)	3254 (28773)	9075 (80242)	102	107	78	17	n/a	9
SI-2.1-Q112	5676 (50190)	2632 (23268)	3304 (29216)	6431 (56864)	3207 (28353)	4406 (38953)	7888 (69746)	108	101	66	16	n/a	8	
Anti-Clockwise	SI-2.1-QA60	500 (4421)	260 (2298)	380 (3359)	1007 (8903)	395 (3492)	563 (4978)	1290 (11406)	14	14	10	6	3	2
	SI-2.1-QA61	630 (5570)	340 (3006)	480 (4244)	907 (8019)	326 (2882)	434 (3837)	1188 (10504)	14	13	9	6	3	2
	SI-2.1-QA70	1160 (10256)	570 (5039)	800 (7073)	2003 (17710)	813 (7188)	1124 (9938)	2565 (22679)	27	27	18	8	5	n/a
	SI-2.1-QA80	2350 (20778)	1150 (10168)	1605 (14191)	4218 (37295)	1625 (14368)	2278 (20142)	5399 (47738)	52	54	37	17	10	6
	SI-2.1-QA110	3893 (34422)	1872 (16554)	2461 (21755)	4589 (40579)	2252 (19909)	3033 (26817)	6230 (55086)	73	75	52	12	n/a	7
	SI-2.1-QA111	5031 (44481)	2444 (21611)	3253 (28766)	6841 (60490)	3512 (31053)	4996 (44176)	9075 (80242)	102	107	78	17	n/a	9
SI-2.1-QA112	6451 (57040)	3219 (28462)	4427 (39143)	5698 (50382)	2645 (23387)	3327 (29417)	7888 (69746)	108	101	66	16	n/a	8	

# Specification

## Hazardous Area Certification

ATEX – II 2G Ex db eb\* IIB T4 Gb (Tamb -40 to +65°C)  
ATEX – II 2G Ex db eb\* IIC T4 Gb (Tamb -20 to +65°C)

IECEX – Ex db eb\* IIB T4 Gb (Tamb = -40 to +65 °C)  
IECEX – Ex db eb\* IIC T4 Gb (Tamb = -20 to +65 °C)

FM – Class 1, Zone 1 AEx de\* IIB T4 Gb  
(Tamb = -40 to +65 °C)  
FM - Class 1, Zone 1 AEx de\* IIC T4 Gb  
(Tamb = -20 to +65 °C)

CSA – Ex db eb\* IIB T4 Gb (Tamb = -40 to +65 °C)  
CSA – Ex db eb\* IIC T4 Gb (Tamb = -20 to +65 °C)

EAC – 1 Ex de\* IIB T4 Gb (Tamb = -40 to +65 °C)  
EAC – 1 Ex de\* IIC T4 Gb (Tamb = -20 to +65 °C)

CCC – Ex de\* IIB T4 Gb (Tamb = -40 to +65 °C)  
CCC – Ex de\* IIC T4 Gb (Tamb = -20 to +65 °C)

UKEX – II 2G Ex db eb\* IIB T4 Gb (Tamb = -40 to +65 °C)  
UKEX – II 2G Ex db eb\* IIC T4 Gb (Tamb = -20 to +65 °C)

\* 'e' or 'eb' increased safety available on single-phase and DC supply voltage only.

Certification temperatures are not operating temperatures; see operating temperature, page 5.

## Rotork Bluetooth® Setting Tool Pro:

Ex ia, IIC T4 Ga (IP54)  
Ex ia, Class 1, Div 1, Group A, B, C, D T4  
FM, INT SAFE Class I, II DIV1 Group A B C D  
CSA, EExia, Class I, II Div 1 Group A B C D

## Functional Safety:

The Skilmatic range has been certified to meet the full functional safety requirements of IEC 61508 Parts 1-7 and is suitable for use in a SIL 2/3 system depending on the configuration.

Please refer to the appropriate safety manual for full failure rate data and any restrictions of use.

## Enclosure:

Watertight to IP67 / NEMA 6, double-sealed protection with separate cable gland and termination compartment. Optional Watertight models to IP68, 7 meters/72 hours, for SI2.1Q60 to Q80, for alternative depth/ pressures consult factory.

## Materials

Control Module: Aluminium

## Actuator – Q60 to 80

Actuator Body: Anodised Aluminium

Piston: Aluminium

Driving Shaft: Zinc plated Steel

Seals: Nitrile, optional materials for high and low temperature applications

## Actuator – Q110 to 112

Actuator Housing: Carbon Steel

Drive Shaft: Carbon Steel

Piping: 316 Stainless Steel (hard piped)

Paint Finish: Standard Grey, powder coated electrical compartments with two pack epoxy hydraulic compartment and actuator drive, minimum 90 microns (see page 5 for additional paint options)

## Mechanical

### Operating Temperature:

See page 5

Torque / Speed: See page 6

Stroke: 0°± 2.5% to 90° ± 2.5%

Weight: See dimensional detail (page 3 & 4)

Failure Mode: Failsafe in the direction of the spring or Fail in last position

Action: Spring-return clockwise or anti-clockwise

Hydraulic Fluid: See page 5

Maximum Working Pressure: 12 bar (175 psi)

Manual Override: Optional gearbox – Gearbox on SI-2Q60 to Q80 or hydraulic hand pump on SI-2Q60 to Q130

### Internal Pressure Transmitter:

Displayed as a percentage of maximum working pressure

Mounting: Valve stem vertical or horizontals (see page 5)

## Electrical

Electrical Supply: Single-phase 115 or 230 VAC, Three-phase 380 to 480 VAC or 24 VDC

Supply Tolerance: Supply voltage ± 10%, frequency 50/60 Hz ±5%

Power Consumption: Available upon request

Motor Protection: Thermal cutouts, insulation class F

Cable Entries: Power module has a minimum of two spare entries. See page 5 plus two plugged M20 cable entries. See Drg No SMW-SI-010 for options. Switchbox spare entry will be plugged ATEX - M20. FM/ CSA - ½"NPT

Position Feedback: 1K ohm. Conductive plastic

### Spring-Return Electric Quarter-Turn Actuator (380 to 4407 Nm)

#### Electrical (cont'd)

##### Remote Digital Inputs:

Open, Close, maintain, ESD and Partial Stroke – Std 20 to 60 VAC/DC or 60 to 120 VAC. Other voltages consult factory. 5 mA minimum duration 300 ms (DC inputs must be +ve switched)

##### Limit Switches:

Two adjustable electro-mechanical SPDT Volt free switches. Rating 5A minimum at 230 VAC. Optional proximity switches are available (See page 5)

##### Non-Intrusive Setting:

Sealed control module with infrared / Bluetooth setting from the Rotork Bluetooth® Setting Tool *Pro*. All values are held within EEPROM to maintain settings within the memory on power failure. Datalogger configurations and recorders can be downloaded via the Rotork Bluetooth® Setting Tool *Pro*

##### Display:

Rotork LCD dual display with 32 character text to allow viewing of the valve position, internal pressure and diagnostics screens. LED's are provided to indicate limits and intermediate state in the remote mode

#### Control

##### Control Options:

Remote Digital (Open, Close, maintain), Emergency shutdown and Partial stroking. Or Analogue Modulating - Input 4-20 mA or 0-10 VDC

##### Resolution:

<0.2% of full scale

##### Repeatability:

<0.2%

##### Duty Rating:

90%

##### Output:

4-20 or 20-4 mA, powered internally by an isolated 24 VDC supply or external customer supply

##### Function Settings:

Control options, Deadband and Hysteresis adjustable 0–99%, Partial stroking adjustable 0–99%, interrupt timer and ESD action

##### Interrupt Timer:

To slow the rate of closing and / or opening over. 0–99% of stroke, with the time pulse ON and OFF duration selectable from 100ms to 99sec. Timer does not operate with loss on power

##### Local Controls:

Lockable Local/Stop/Remote selector switch and local Open/Closed switch

##### Alarm and Limit Relays:

*Relays:* Volt free normally open or normally closed contacts rated 5 mA to 5A 120/230 VAC, 30 VDC

##### Alarm Monitor Relay:

De-energised on loss mains power, hardware, local controls, position sensor fault, and EEPROM error. Optional signal inverted to de-energise monitor relay for low power applications

##### Three Independent Alarm and Status Relay:

Can be configured to customer specific alarms and status indication.

##### Fieldbus Communication Options (internally mounted):

*Pakscan:* Rotork fieldbus system for remote control and status indication over a fault tolerant two-wire serial link. Loop distance up to 20 km. (See PUB059-048)

*Modbus:* Single and dual communication highways RS485. Modbus protocol RTU (See PUB091-001)

*Profibus DP:* Fully compatibility with EN 50170 (See PUB088-001)

##### Foundation Fieldbus:

An IEC61158-2 compliant Foundation interface module allows connection to a foundation network. (See PUB089-001)

##### DeviceNet:

ODVA certified DeviceNet interface, with full status data feedback, digital and analogue control (See PUB090-001)

For modulating applications consult factory regarding resolution on all fieldbus cards

Rotork reserves the right to change the specifications without notice.

A full listing of the Rotork sales and service network is available on our website.

[www.rotork.com](http://www.rotork.com)

#### Corporate Headquarters

Rotork plc

tel +44 (0)1225 733200

email [mail@rotork.com](mailto:mail@rotork.com)

#### USA

Rotork Controls Inc.

tel +1 (585) 247 2304

email [info@rotork.com](mailto:info@rotork.com)