

rotalk 30



CVA heralds new age of electric actuation for process control valves

Full story on Pages 10 and 11

Also inside:

Product News

Pakscan digital control goes wireless

Company News

Focus on Skilmatic

Rotork company website gets smart new look - Page 18

Helping to get **clean water to Southern Iraq**

Rotork actuators have been supplied for a project designed to provide an uninterrupted supply of water to the Iraqi province of Basrah and develop the infrastructure to improve the quality of life for the citizens.

Included in the contract, IQ and AWT electric actuators have been ordered for gate valves and ball valves manufactured by JC Fábrica de Válvulas, S.A. (pictured) for new plant that will increase the treated water supply capacity to the province from 4,000 to 16,000 cubic metres/hour.

JC's valve manufacturing facility in Sharjah supplied the actuated valves to the Comet Company, Rotork's agent in Iraq, who co-ordinated the project with the client.

The project is funded by the US Army Corps of Engineers, who are investing \$9.5 million to increase the capacity of pumping units at Qurmat Ali and install new chlorination systems.

The contract was awarded to the Al Dayar United Company for General Construction in January 2008 and is due for completion by the end of the year. The actuators on the project are locally supported by the Universal Technical Company and Rotork's UAE sales office in Abu Dhabi.





rotork®
Controls

rotork®
Fluid Systems

rotork®
Gears

rotork®
Site Services

rotalk³⁰

INDUSTRY LEADING VALVE ACTUATION
NEWS FROM THE WORLD OF ROTORK

INTRODUCTION:

Helping to get clean water to
Southern Iraq..... 2

CONTRACT NEWS:

Rotork contract stories from
around the world..... 4-7 & 12-16

PRODUCT NEWS:

Pakscan digital control goes wireless..... 8
Design Features - Custom Actuators..... 9
CVA heralds new age of electric actuation
for process control valves..... 10 & 11

FEATURES:

Focus on Skilmatic..... 14 & 15

COMPANY NEWS:

Site Services News..... 17
Rotork website gets smart new look..... 18

CONTRACT NEWS

Rotork actuators “enhance the reliability” of SSE power stations’ environmental upgrades

Over 100 Rotork IQ and IQT intelligent electric actuators have been installed across the new FGD plants at the SSE owned Ferrybridge and Fiddlers Ferry Power Station sites.

“The reliability of Rotork actuators will assist in enhancing the reliability and availability of the FGD plant as well as the rest of the station” says David Bosomworth, Technical Engineer and Flue Gas Desulphurisation (FGD) Liaison Officer at the Scottish and Southern Energy (SSE) owned Ferrybridge ‘C’ Power Station in Yorkshire.

The Power plant upgrades will significantly reduce the sulphur dioxide emissions from the coal fired power stations in line with the European Union’s Large Combustion Plant Directive (LCPD).

Rotork actuators for the FGD plants were ordered by valve maker KSB through Rotork in France. Exeeco, the specialist Power Station site services company in the Rotork Group, has held a framework agreement for the supply of electric actuators and the service and repair of installed actuators at all of the Scottish and Southern Energy fossil-fuelled and hydro-electric power station sites since 2001. Added to this, Rotork’s activities over many years, including retrofitting to replace obsolete equipment and the installation of actuators on Low Nox and BOFA upgrade programmes, has facilitated the stocking of common

plant spares which has assisted the planning of programmed maintenance activities.

Manufactured and installed by AE&E Lentjes, the FGD plants were designed to have both electric and pneumatic actuation. David Bosomworth comments “ I was very pleased that Rotork electric actuators had been selected to be installed at both sites as we have firsthand experience of the Rotork IP68 “double-sealed” design’s ability to successfully withstand the challenging elements of the Power Station environment and the benefits of the non-intrusive commissioning and data communication technologies. ”



David Bosomworth (right) on site at Ferrybridge with Exeeco Sales Director Ian Elliott

“The reliability of Rotork actuators will assist in enhancing the reliability and availability of the FGD plant as well as the rest of the station.”



Exeeco engineer Jonathan Darker inspects IQ installations on the Ferrybridge FGD plant

Rotork Site Services awarded **valve actuation framework agreement** for RWE npower power stations

The contract has been awarded to Exeeco Ltd, a Rotork group company with over thirty years of specialist experience of valve actuation services in the power generation industry. A representative from RWE npower explains: “Rotork Site Services has supplied hundreds of actuators, assisting with the upgrade and prolonged life expectancy of our utilities.”

“We were pleased to award this framework agreement, which provides a commitment for future plant upgrades.”

RWE npower has awarded a framework agreement to Rotork Site Services for the supply of Rotork valve actuators and actuation maintenance services throughout all of its UK fossil-fuelled and cogen power stations.



Aberthaw Power Station

Rotork in the Mongolian coal industry

Valve actuation applications don't get much more arduous than those experienced in the coal industry and when the end user's plant is situated in the harsh environment of Inner Mongolia, the successful achievement of long term reliability becomes even more vital.



GP range pneumatic actuator with manual hydraulic override

Photographed in the workshops of valve distributor Triflow Corporation, this Rotork GP range pneumatic actuator (above) with manual hydraulic override is operating a 24 inch Class 2500 347 stainless steel Adams butterfly valve with hardened trim, protective seats and seals and purging. The valves are used on highly abrasive, ultra-high pressure applications in the Axens 'T-Star' coal liquefaction technology supplied to the Shenhua Group Corporation of China.

This is the first-of-a-kind direct coal liquefaction plant and will produce about 19,000 barrels per day of oil from coal in a single train plant at the Inner Mongolian site.

Axens was selected due to the company's extensive experience with heavy oil conversion and coal liquefaction, the 'T-Star' technology being the latest development in over forty years of commercial operations.

Many more Rotork GP range actuators - some in massive sizes - are installed at the site, operating Mogas metal seated ball valves in various sizes and specifications. Some of these valves also feature Class 2500 pressure ratings, 347 stainless steel construction and special seals.



Rotork Houston Area Manager Keith Phillips is pictured on site (right) with Jinny Zhu, Mogas Sales Manager in Beijing, and Chuck Walker, Mogas Valve International Sales Manager

4 million cycles - and still going strong

Rotork Fluid Systems in Rochester NY recently supplied some hydraulic cylinder seal kits to an Owens Corning fibreglass insulation plant in Ontario, Canada.



"...This amounts to 960 cycles per day, over 350,000 cycles a year..."

The standard buna-N seals are for nine double-acting hydraulic actuators (Model H25003DA) originally installed in 1996 on a high-cycle application.

In continuous and unchanged service conditions for over twelve years, the actuators have stroked for one cycle every 90 seconds. This amounts to 960 cycles per day, over 350,000 cycles a year - more than 4.2 million cycles since installation and still going strong!

More Rotork actuators ordered for Rocky Mountain gas processing plant...

Rotork GP range pneumatic spring return actuators have been specified to operate ball valves manufactured by DHV Industries of Bakersfield, California, on Phase 2 of the Meeker Gas Plant in Rio Blanco County, Colorado.



Some of the valves and actuators for the Meeker Gas Plant at the DHV Industries factory

Seventeen actuators, ranging in size from GP130 to GP270, will control applications including booster compression inlet isolation, expander inlet isolation and NGL booster pump inlet isolation at the new plant, which will double the processing capacity of the Meeker

facility to 1.5 bcf/d of natural gas and 70,000 b/d of NGLs (natural gas liquids). The Meeker facility is operated by Enterprise Products, who have been processing gas at Phase 1 of the project - where Rotork Fluid Systems actuators are also installed - since 2007.

...and Scandinavian gold mine

Construction is well underway at the Kittila Gold Mine in northern Finland, approximately 900 kilometres north of Helsinki.

Named after the nearby community of the same name, the Kittila mine will initially extract gold from an open pit, followed by underground mining through a ramp access. Current reserves are sufficient for an estimated running life of 13 years.

The photo shows ten of the thirty Rotork CP and GP range pneumatic valve actuators ordered for the project by Mogas Valve.



CONTRACT NEWS

Rotork's "vast experience in the field" secures Scandinavian tank farm contract

The Vopak 'Skarvik 1' project at Skarvikshammen in the City of Gothenburg is the largest petroleum tank storage project in Scandinavia for twenty-five years and will be the first fully automated installation of its kind in Sweden.

Ten new tanks are being constructed and a new PLC-controlled SCADA system installed to enable Class 1 hazardous products including petroleum to be pumped to and from any location on the site

Rotork has supplied over eighty ATEX approved IQPro intelligent electric actuators with factory-fitted Profibus cards for flow control duties throughout the site, operating gate valves on the tanks and on a new main manifold and pipe rack that will distribute the products around the plant.

Vopak's Project Manager Per Follin explains: "We selected Rotork as our actuator supplier following an evaluation of our installed base



IQPro actuators installed during construction of the new main manifold at Skarvik 1

across other Vopak sites worldwide. Rotork has a vast experience in this field and the reliability, functionality, diagnostic abilities and ease of maintenance of its products were all factors contributing to our

decision." The main contractor for the Vopak 'Skarvik 1' project is the Swedish construction group NCC. Valve and pipework installation is being performed by the specialist contracting company NVS, who

ordered the actuators from Rotork's Swedish agent Alnab Armatur AB.

Alnab is providing local support for installation, commissioning and after-sales service.

Rotork actuators in 'milestone' Chinese water supply project



Rotork IQPro 35 actuators photographed at the Tielin Valve factory in China, fitted to 2400mm diameter pipeline butterfly valves for the Dahuofang Water Supply Project

Rotork IQPro intelligent electric valve actuators have been specified for one of China's largest ever water infrastructure improvement projects.

The Dahuofang Water Supply Project consists of a 231 kilometre pipeline, one pump station, six water distribution stations and a buffer tower. The network will take water from the high rainfall area of Dahuofang Reservoir and distribute it to six cities in the dryer and heavily industrialised areas of Liaoning Province.

Over 140 IQPro actuators have been ordered, mostly to operate pipeline and pump station butterfly valves manufactured by German and Chinese valvemakers. Some of the IQPro actuators are modulating versions for control valve duties at

"The Dahuofang scheme is viewed as a 'milestone' in worldwide domestic water supply projects"

the pipeline distribution stations. All of the actuators are Modbus-enabled to suit the digital bus control protocol selected for the extensive pipeline network.

The Dahuofang scheme is viewed as a 'milestone' in worldwide domestic water supply projects in terms of capacity and geographical length.

The project includes a water supply tunnel with a length of 85.3 kilometres, which will supersede the 54 kilometre Seikan Rail Tunnel in Japan as the world's longest when completed.

Natural gas transportation and processing project at Fort Worth

Over 75 P range pneumatic actuators have been supplied for a natural gas transportation and processing project in the Fort Worth area of northern Texas.

The Worsham-Steed expansion project involves the construction of a new pipeline and plant capable of processing 60,000 Mcfd of natural gas, yielding up to 120,000 gallons per day of NGLs (natural gas liquids),

Rotork Fluid Systems supplied the actuators to Specialty Equipment, an RFS authorised distributor in Louisiana, who fitted the valves and despatched the completed MOVs to site.



One of over 75 P range pneumatic actuators supplied

Rotork's agent in Sweden, Alnab Armatur AB, has won an order for 78 IQT intelligent actuators with Pakscan two-wire digital control to operate Alfa Laval backwashing water filters designed for process cooling and associated applications.

The filters are being supplied to Alfa Laval's customer in the United Arab Emirates. The filters are used to protect heat exchangers and other sensitive equipment from clogging and breakdowns. Automatic backwashing utilises two integral actuated butterfly valves, operating primary and secondary flushing operations.

Pakscan-enabled Rotork actuators preferred for Middle East process filtration project

Bjorn Nilsson from Alnab explains: "We have been supplying the valves for the filters to Alfa Laval for many years, but for this contract the end user was aware of the benefits of using Rotork IQT actuators and Pakscan, enabling us to supply a complete actuated valve and control system package for the project."

In the UK, another backwashing water filter company, Cross Manufacturing, is now also offering its equipment with the option of IQT actuator operation. A spokesperson explained that the



The Cross Phoenix IQT automatic backwashing water filter



Bjorn Nilsson is pictured with some of the IQT actuated Alfa Laval water filters

combination is designed to be especially attractive for applications in the water and waste water treatment industries, where the advantages of Rotork IQ actuation technologies are widely recognised and the filter can therefore dovetail seamlessly into existing or preferred control and instrumentation protocols.

"We have been supplying the valves for the filters to Alfa Laval for many years, but for this contract the end user was aware of the benefits of using Rotork IQT actuators"

Pakscan digital control goes wireless

Starting with site trials in 2009, Rotork is extending the capabilities of the globally successful Pakscan control system with the addition of a wireless option.



The modular nature of the P3 Pakscan master station now allows the user to have the choice of a fully wired loop for control and monitoring, a fully wireless control and monitoring system or wired control with wireless monitoring.

Utilising the internationally accepted 2.4GHz frequency the Pakscan P3 wireless network card gives the user access to all the standard data available from the wired Pakscan system, together with the diagnostic and asset management information stored by the actuator data logger and configuration files. It allows easy extraction of these files, which up until now have only been downloadable locally, using hand held tools.

The wireless system also increases the available node count of each master station to 300, and has a line-of-site operating range of approximately 70 metres indoors and 1000 metres outdoors.

The use of meshing and repeaters further increases the range to individual field units.

To provide robust on-site communications, the wireless option operates with a meshing system which will ensure that all nodes have the facility of at least two routes back to the master station. If the normal traffic route is blocked, the network will find another way to route the messages. This self-healing network complements the loop-back capabilities of the established Pakscan two-wire loop and therefore makes it an ideal addition to the Pakscan range. Along with the existing in-built security features of the P3 system, the security of data over the air is ensured by using encryption facilities.

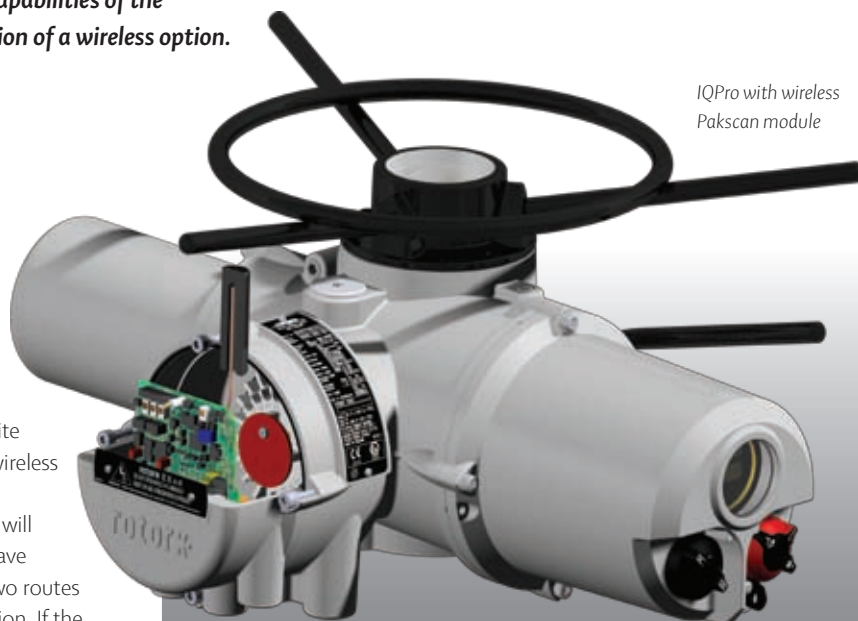

IQPro with wireless Pakscan module

The benefits of the Pakscan wireless system include:

- Removal of cable and wiring installation costs
- Elimination of potential wiring issues
- Easy installation
- Reduced commissioning and decommissioning times
- Easy to expand and easy to retrofit on existing plant
- Highly reliable and secure data transfer
- Mesh configuration for increased network availability
- Elimination of wires, bundled cables, junction boxes and marshalling panels
- Lower engineering costs

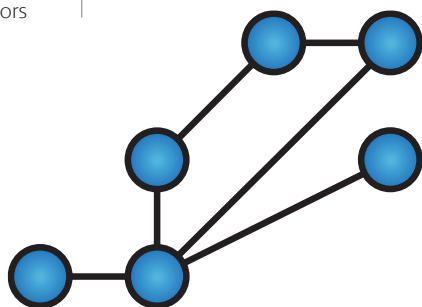

Self-healing mesh networks allow continuous connections and reconfiguration around broken or blocked paths

Support for third party devices is possible using a General Purpose Field Unit (GPFUCU), where the communications from the supervisory control system are transparently routed to the device.

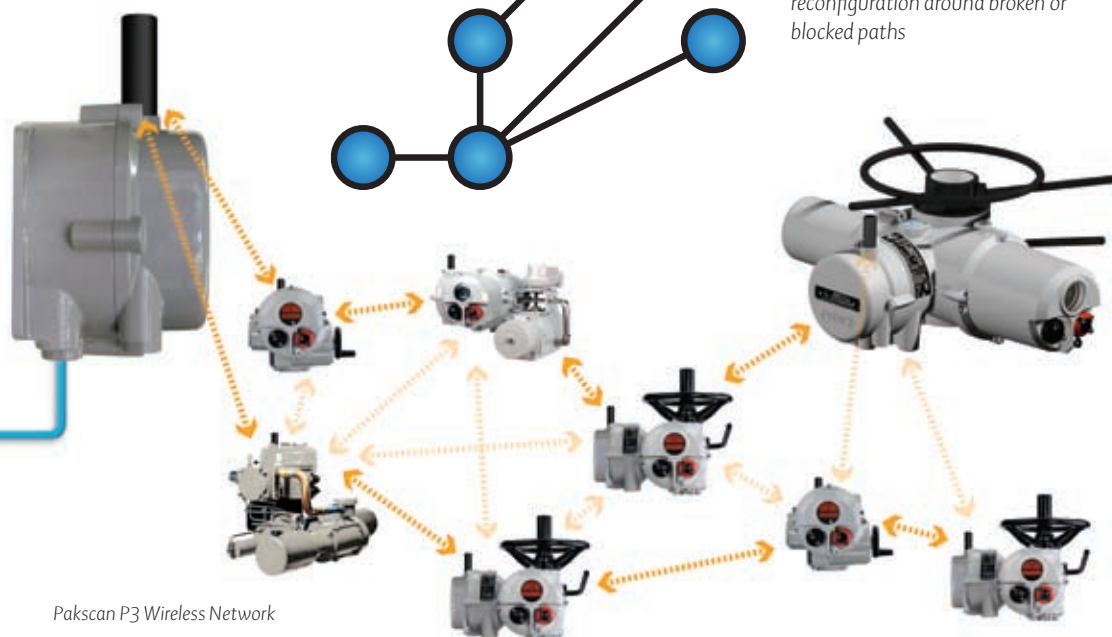

Pakscan P3 Wireless Network

Pakscan P3 wireless offers simple access to asset management information.

Built in web pages make it possible to easily extract actuator data logger and configuration files from the control room.

HPG in the picture

The Enbridge pipeline system is one of the world's longest and most sophisticated oil industry networks, encompassing total pipeline lengths of 13,500 kilometres (8,500 miles) and transporting two-thirds of Canada's crude oil products from the Western Canadian Sedimentary Basin.

HPG direct high pressure gas actuators are specially modified developments of Rotork's rugged H or GH range of hydraulic actuators that use the pressurised gas from within the pipeline itself to operate the valve. This eliminates the need for a separate source of power, the actuators requiring only an electrical supply for control and indication.

On natural gas pipeline installations this makes the HPG design especially popular for valve control and safety duties in remote areas.

Rotork's HPG actuator design embodies several design features providing commercial, environmental, maintenance and safety advantages. Commercially, the design consumes less pipeline gas in operation, since the gas is going directly into the actuator cylinder rather than separate gas/oil tanks.

Environmentally, the pipeline gas is isolated from any oil supply. High pressure gas is introduced



directly into one actuator cylinder whilst the other cylinder, on the opposite side of the centre body, is only used for speed control and hydraulic manual override.

At the end of valve travel, therefore, only high pressure gas is exhausted into the atmosphere, rather than the gas/oil mixture associated with rotary vane type actuators, which over time leaves a sheen of oil on the ground and surrounding equipment.

Maintenance-wise, if the high pressure gas seals have to be replaced, the actuator can be left mounted on the valve and the work carried out on site. Rotary vane actuators must be removed from the valve in order to replace the vane seals and there is virtually no way of doing this without dismantling the actuator.

Safety-wise, with the HPG remaining on the valve during seal replacement the valve can still be opened or closed, since the hydraulic manual override can be operated even when the high pressure gas cylinder is removed.

The HPG actuator shown above is one of seven supplied to Puffer Sweiven to operate Rockwell plug valves on bypass valve duties at the Egan natural gas storage facility in Acadia Parish, Louisiana.

The actuators were successfully shipped within a 7-9 week time frame requested by end user Duke Energy.



This specialised Rotork Fluid Systems HPG direct high pressure gas actuator provides vital over-pressure protection on a section of the Enbridge Pipeline in Canada

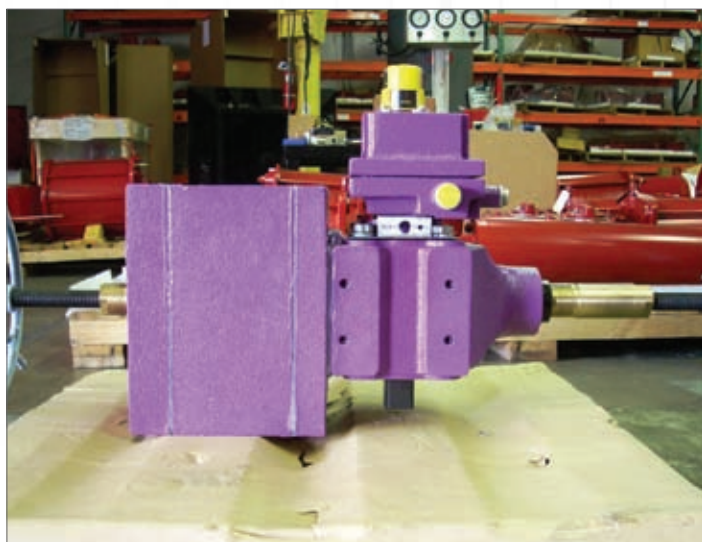

CP range pneumatic actuator (Model CP/D-065-280BA-MH)

Shutdown Service Duty (SDV) in the petrochemical industry

As evidenced by its unusual shape and colour, this CP range pneumatic actuator (Model CP/D-065-280BA-MH), complete with switch control box, has been equipped with a K-Mass fireproof coating, enabling it to operate in the seat of a fire.

The K-Mass coating swells in the heat to provide effective

insulation for up to 30 minutes at a temperature of 1000°C.

The actuator has been supplied to the Middle East for SDV (shutdown service) duty in the petrochemical industry, complete with a 60 gallon air receiver that will allow the actuator to be stroked if the instrument air supply is lost.

Rotork's CVA heralds new age of electric actuation for process control valves

CVA – a revolutionary new electric actuator for the operation of process control valves.

The Rotork CVA range provides continuous, repeatable modulating control with a programmable fail to position option. Operating on an industry-standard 4-20mA control signal or digital bus, the CVA offers high resolution and repeatability, making it suitable for the most demanding applications.

Linear and Quarter-turn

Available for the direct-drive actuation of linear or quarter-turn control valves, the CVA draws on Rotork's fifty years of experience and innovation as the world's leading designer and manufacturer of industrial electric valve actuators. The result is a range of actuators that demonstrates highly accurate control valve automation, combined with advanced, non-intrusive calibration, valve diagnostics and the simplicity, user-friendliness and economy of electric operation. Mechanical features include Rotork's well-known 'double-sealed' enclosure, whereby internal electrical components are permanently protected from the effects of the operating atmosphere.

The IP68 dust tight, watertight and temporarily submersible (7 metres, 72 hours) enclosure is universal to all models in the CVA range, including those with hazardous area approvals. The CVA is engineered to deliver high precision valve positioning and facilitate the tightest possible tolerances on the process variable, enabling process quality and output to be optimised. On loss of mains power, built-in super-capacitors allow the CVA to move the valve to a desired position, programmable as open, close, any intermediate position or stay-put. Manual operation is also optionally available.

'Non-intrusive' communication

The CVA utilises a new variant of Rotork's innovative and well established 'non-intrusive' communication technology for actuator programming and adjustment. Actuator set-up and configuration is performed using a Bluetooth enabled PDA or PC running Rotork Enlight software which is freely downloadable from the Rotork website.



Rotork's specialist Site Services organisation is available on a global basis to provide comprehensive support in these areas, from advice and surveys to installation and commissioning.

When complete, the full range of CVA actuators will have a maximum rated thrust of 22.2 kN (5000 lbf) with a maximum stroke of 114.3 mm (4.5 inches), whilst quarter-turn actuators will supply a maximum rated torque of 677.5 Nm (6000 inch lbs), enabling the range to operate most control valve types and sizes. Actuators can be specified for single-phase AC or DC electrical supplies.

The launch of the CVA follows an exhaustive programme of market research, product development and field testing. Research has identified significant enthusiasm for the introduction of viable electric actuation in the control valve market. The benefits in the reduction of on-going plant running and maintenance costs are apparent to both plant operators and owners.

Every CVA incorporates an onboard data logger, enabling operational data such as valve torque profiles, dwell times, actuator events and statistics to be downloaded for detailed investigation and diagnosis. After analysis, any required configuration changes can be uploaded into the actuator.

Digital control bus connectivity options for the CVA initially include Hart and Foundation Fieldbus protocols, facilitating enhanced installed economy as well as giving the CVA the increased ability to dovetail into existing asset management systems. The all-electric CVA design also simplifies the process of retrofitting actuators onto existing valves.



CVA in action

“The CVA is working perfectly. It holds the set point, no deviation and responds very quickly to a change” says Mike Angellini, Chemical Laboratory Supervisor at Brayton Point Power Station (pictured right) in Somerset, Massachusetts, USA.

Controlled by a 4-20mA signal, the CVA is installed on a three-way, two-inch hot water blending valve in the station’s demineralisation plant.

It has replaced a spring diaphragm actuator and pneumatic positioner that had proved to be unreliable and suffered from exposure to the harsh conditions that are synonymous with power station environments. The operators are now also able to close the valve at the end of a cycle for isolation of the hot water tank, which they could not do before due to the unreliability of the positioner.

Mike concludes: “It does exactly what we want for positioning. We don’t even know it is there.” He is now looking for other applications for the CVA in his plant and would be happy to talk to other potential CVA

users about his experience with the actuator. He can be contacted on (+1) 508 646 5431.

In the UK, Drax Power Station (below) has installed a CVA on a one-inch globe control valve that regulates the steam inlet temperature in the boiler fuel oil pump house.

The CVA has replaced a pneumatic actuator and positioner and operates from the same 4-20mA signal. Operation has been successful, with zero deviation from the desired value to the measured value, and as a result the operators will be looking at the CVA as an option for future control applications at the station. Another factor in its favour has been the ease with which it was installed on the existing valve.



“Operation has been successful, with zero deviation from the desired value to the measured value”



CONTRACT NEWS

Actuators for 'clean' oil processing plant in Canada

Rotork enjoys a long association with the Canadian oil sands industry, which is recognised as the largest single petrochemicals resource on the North American continent.

Over the years thousands of Rotork valve actuators of all descriptions have been supplied to the industry for the processing and transportation of this valuable resource.

One of the latest Rotork contracts involves 180 GP and CP range heavy duty pneumatic actuators supplied to Mogas Valves for the first phase of the Shell Scotford Upgrader Expansion Project. The Scotford Upgrader, which is situated next to Shell Canada's Scotford Refinery, near Fort Saskatchewan, Alberta, uses hydrogen-addition technology to upgrade the high viscosity heavy crude oil (bitumen) from the Muskeg River Mine into a wide range of synthetic crude oils.

The process has significant environmental advantages, introducing dramatically lower levels of sulphur dioxide emissions and producing synthetic crude oils which enable refiners to manufacture clean, high quality products, including petrol and diesel, with low levels of aromatics, particulates and sulphur. The expansion project will create a 60% production capacity increase when completed in 2010 as well as significant new employment opportunities in the area.

Photographed in the Houston workshop of Rotork Fluid Systems are some of the 180 GP and CP range pneumatic actuators for the Scotford Upgrader contract await shipment to valvemaker Mogas.



GP range pneumatic actuators

Refinery contract heralds expansion in Serbia

Situated on the west side of the city of Belgrade, the NIS-RNP Pancevo Refinery is a major producer of fuels, solvents, bitumen and feedstock for the petrochemical industry in Serbia and beyond.



Some of the IQTM installations at Pancevo



A recent upgrade programme at the refinery has introduced computer controlled blending, for which Rotork has supplied a total of 266 IQTM intelligent modulating actuators, operating control valves manufactured by Metso.

All actuators are Profibus-enabled to suit the PLC protocol installed to control the operation of the new plant. To support this significant contract for Rotork actuators, a technical office has been opened in Belgrade by Josip Bunic, who has been working with Rotork since 1978. The new company in Serbia, Elrot d.o.o., is managed by

Milan Beric, pictured above, and will provide a local source for sales support, service and maintenance for the actuators installed at the Pancevo Refinery, as well as additional support for Rotork's sales activities in the surrounding areas.

Rotork has supplied a total of 266 IQTM intelligent modulating actuators, operating control valves manufactured by Metso

Improving the gas flow in Korea

Pokorny, Rotork's agent in the Czech Republic, is busy with local valvemaker MSA supplying IQ electric actuators for Kogas – the Korea Gas Corporation – on a number of significant gas terminal, pipeline and pump station projects.



Rotork actuated MSA trunnion mounted ball valves awaiting despatch to Korea



Actuators installed at one of the pipeline pump stations



"In total, more than 300 IQ actuators have been ordered by MSA for these projects."

The upgrade and expansion of South Korea's natural gas infrastructure has been on-going for several years, with Rotork actuators supplied on many projects, including these recent examples involving MSA Class 300 – 600 ball valves in sizes up to 30 inches in three-piece bolted or fully welded and trunnion mounted three-piece designs. New pipelines from the LNG terminal at Incheon

to Kyeongseo and from Namyangju to Kunja, the replacement of manual valves and obsolete motorised valves during improvement programmes on existing pump stations at various locations and valves for new pump stations at Hong Cheong and Oe Dong. In total, more than 300 IQ actuators have been ordered by MSA for these projects.

Electric, pneumatic and hydraulic actuators for North Sea floating production unit

Rotork actuators have been ordered for installation on a new floating production unit under construction for the Statoil Gjoa project in the North Sea.

The semi-submersible vessel will operate in a water depth of 380 metres in the Norwegian North Sea area and will come on stream in 2010. Aker Solutions has been awarded the contract for the topside engineering and construction, which will be assembled on a hull constructed by Samsung Heavy Industries in South Korea and transported to Aker Stord, south of Bergen.

To date, more than 100 Rotork IQ electric, CP pneumatic and RH and GH hydraulic actuators have been supplied to butterfly valve manufacturer Solent and Pratt for various applications on the vessel.



Included in these, more than 80 RH rack and pinion hydraulic actuators will be used on ballasting butterfly valves in sizes 6" and 12", manufactured in titanium and Super Duplex materials.

These valves will be intermittently submerged at depths up to 45 metres during the operation of the vessel. This particularly arduous and critical duty demands special attention including the fitting of stainless steel IP68 Exi ATEX certified

To date, more than 100 Rotork IQ electric, CP pneumatic and RH and GH hydraulic actuators have been supplied to butterfly valve manufacturer Solent and Pratt for various applications on the vessel.

explosionproof switchboxes with position indicators, manufactured by K Controls. The valves, actuators and switchboxes are being packaged and tested at the Solent & Pratt factory in Bridport.

FOCUS ON SKILMATIC

Pipeline actuators facilitate solar powered solution for remote valve control

The Puesto Hernandez-El Corcobo Norte Oil Pipeline traverses eighty kilometres of remote and virtually deserted wilderness in the Neuquen area of south-west Argentina, close to the border with Chile.

In this unforgiving environment – where fluctuating ambient temperatures drop well below zero in Winter – the vital provision of reliable, remote valve control and indication has been successfully achieved by the use of Modbus-enabled Skilmatic EH Range electro-hydraulic actuators, operated by solar powered battery packs.

The actuators provide double-acting on-off control for Wenlen 12 inch ANSI Class 600 pipeline ball valves in six locations along the pipeline's route through the wilderness. The self-contained electro-hydraulic actuators operate from a 24 Volt DC power supply, facilitating a solar powered solution that is efficient, environmentally friendly and economical, saving the potentially significant environmental harm and cost of installing mains power sources along the length of the pipeline.

The innovative EH actuator design comprises an integrated control module, a hydraulic manifold and a power unit consisting of a motor, hydraulic pump and reservoir. Protected by a waterproof and explosionproof enclosure,

“The combination of features inherent in the EH design makes it an ideal choice for remote pipeline valve actuation and facilitates the use of renewable energy sources such as solar power whenever possible, as illustrated by this project.”



Paplo Patane from Industrias Metalart S.A. is pictured with one of the Skilmatic EH actuator installations, framed by solar panels

Dakota Gasification

Pictured here is one of three Skilmatic EH actuators installed on block valve duty at the Tioga Pump Station in Canada. The station is situated on the 200 mile

CO2 pipeline, which runs from the Dakota Gasification Great Plains Synfuel Plant in North Dakota to the Canadian town of GoodWater in the EnCana Weyburn oil field.



EH electronic functionality benefits from Rotork's IQ intelligent electric actuation technology, providing configuration, diagnostics, fault indication and position indication by means of a digital visual display and non-intrusive, two-way infrared communication with a hand-held programmer. The actuators on the Puesto Hernandez-El Corcobo Norte Oil Pipeline are controlled and monitored by a SCADA system utilising the Modbus digital bus protocol.

Gabriel De Visnyey, Rotork Fluid Systems Regional Sales Manager for Latin America comments: “The combination of features inherent in the EH design makes it an ideal

choice for remote pipeline valve actuation and facilitates the use of renewable energy sources such as solar power whenever possible, as illustrated by this project.”

The Puesto Hernandez-El Corcobo Norte Oil Pipeline has been constructed by engineering contractor Arcan with procurement and construction contractor Skanska S.A. for Petroandina Resources, the Argentinian oil transportation company. The EH actuators were supplied and commissioned by Rotork's agent in Argentina, Industrias Metalart S.A. and the solar powered power supplies were designed and manufactured by Solartec.

Actuators supplied to the Natural Gas Corporation of Trinidad and Tobago



Pictured (left) during despatch from the Rotork Rochester NY factory, these are two of the nineteen Skilmatic EH actuators supplied to the Natural Gas Corporation of Trinidad and Tobago (NGC) for the Phoenix Valve Station upgrade project in Trinidad.

NGC chose the EH as it allows them to operate the valves without having to use untreated gas from the onshore pipeline.

Two of the nineteen Skilmatic EH actuators supplied to the Natural Gas Corporation of Trinidad and Tobago (NGC)

ESD duties in the Alaskan oil industry

The project is part of BP Exploration Alaska's ongoing Oil Transit Line upgrade and repair project on the network that carries oil from North America's largest oilfield, Prudhoe Bay on Alaska's North Slope, to the Trans Alaska Pipeline System.

Rotork Fluid Systems Area Manager Tom Degaetano explains: "The Rotork EH actuators were selected for emergency shutdown (ESD) service at the boundaries of each processing plant and pump station, to allow for plant shut in and isolation."

The Skilmatic self-contained, electro-hydraulic actuator is available in double-acting or spring-return



failsafe configurations for quarter-turn or linear valves, offering a secure, electrically operated method of ESD valve operation.

Photographed in Rotork California's Petaluma workshop (left), these two 16 inch ANSI Class 2500 Cameron ball valves are equipped with Skilmatic EH actuators to provide emergency well pad shut down duty on the BP Exploration

Z-Pad Expansion project, involving approximately 120 well heads at Prudhoe Bay.

Also photographed at Petaluma (above), these two Skilmatic EH range actuated valves are amongst the total of twenty-three electro-hydraulic and six low pressure pneumatic actuators supplied to the BPX OTL21 project in Alaska.



"The Rotork EH actuators were selected for emergency shutdown (ESD) service at the boundaries of each processing plant and pump station, to allow for plant shut in and isolation."

CONTRACT NEWS

Profibus actuators control the flow at 'green' water improvement scheme

UK utility company Wessex Water is installing Rotork intelligent electric valve actuators throughout a £25 million project to improve the quality of water supplied to over 200,000 customers.

Maundown water treatment plant was built in the 1960s and first extended in the early 1970s. The site, which treats water from two nearby reservoirs, is now being entirely redeveloped to further improve the quality of drinking water, upgrade the water treatment facilities and meet increased peak demand for water in the area.

Under PLC control, Profibus-enabled Rotork IQ and IQT electric actuators will operate penstocks and butterfly valves to control the flow of water and sequential backwashing operations throughout the new state-of-the-art treatment plant, comprising raw water screening, dissolved air flotation, rapid gravity filtration and granular activated carbon treatment followed by chlorine contact tanks. As well as increasing the treatment capacity to 82.4 Ml/D, the improved

Rotork has supplied more than 200 actuators for the Maundown project, which has the support of the UK Government's Drinking Water Inspectorate and is due to be completed by the end of 2008.

treatment processes will overcome taste and odour problems caused by increased algal blooms in the local water sources resulting from changing weather patterns. The work at Maundown is being carried out by Wessex Engineering and Construction Services, utilising



Paul Roberts from Wessex Engineering and Construction Services and Tony Scott from Rotork discuss the actuator control system and installations on the dissolved air flotation tanks in the new Maundown building

specialist sub-contractors and the existing framework supply chain management system for materials. The controlling software and SCADA programme for the new treatment plant has been written by Wessex Automation, who have standardised on drives, valves, actuators and instrumentation in all areas. Instrumentation is being supplied

by Endress & Hauser, who are also integrating all the process elements into the Profibus control system.

Wessex Water has an enviable reputation for environmental awareness, which is evident in every aspect of the Maundown scheme. Flow through the treatment processes is propelled by gravity, without the assistance of energy consuming pumps, whilst en-route from the reservoirs the flow into the works operates a turbine to supplement the supply of electricity to the site. Additional renewable energy will be provided by solar panels to complement the site's wood pellet burning heating system.

The new building has been designed with a sedum (green) roof, providing excellent all-year-round insulation and a natural habitat for wildlife, as well as helping the site to blend into its rural surroundings. All the water from the roof is collected with the site's surface water and stored in a dirty wash water tank, from where it is channelled into the head of the treatment works.

Rotork has supplied more than 200 actuators for the Maundown project, which has the support of the UK Government's Drinking Water Inspectorate and is due to be completed by the end of 2008.



Increasing Site Services activity has triggered substantial workshop expansion programmes in recent months, including these at two Rotork centres.

In the Netherlands, the busy workshop has been extended to enable larger Fluid Systems actuators to be handled and up to forty actuators a week to be fitted to valves, more than doubling the previous capacity.

The range of the five tonne overhead crane has also been extended to enable direct truck loading and unloading, whilst two beam-mounted 250 kg cranes now serve the service workbenches – including a new actuator test rig – eliminating the need to manually lift and carry

Bigger workshops, increased capacities, improved services



the factory fitting of actuators to larger quantities of valves than was previously possible. Improved access to the workshop is directly linked to new crange covering the majority of the floor area. New, enclosed storage has been installed, embodying computerised tracking of every actuator's status and progress through the workshop.

Pictured here with Rotork BV General Manager Frank Koopmans (centre) and Sam Soumokil (right), Peter France's workshop skills were put to good use during the opening celebrations!

Work is performed on four fixed and two mobile bench stations, providing increased flexibility by permitting outside technicians to support the permanent workshop technicians during workload peaks. A new production test rig has also been installed for performance testing of all actuators on completion of work. The increased workshop space also enables a new inside/outside technician to be employed for local service on a same day or next day basis, supported by a fully equipped service vehicle.

the actuators. Further facilities have also been put in place to take care of the factory-fitting of Remote Control actuators to valves. These improvements go hand-in-hand with the implementation of new, more efficient work practices, whilst the company has also been awarded the certificate enabling apprentices from local technical colleges to be employed and trained.

The first of these has already been taken on. Rotork Chief Executive Officer Peter France officially opened the new workshop during a recent visit to the Netherlands, pictured above. In the UK, the workshop facilities at the Rotork head office have been completely upgraded in response to a 75% increase in demand. The new workshop is custom designed to efficiently facilitate the actuation overhaul, repair and upgrade activities performed, as well as



Workshop facilities at the Rotork head office

SITE SERVICES NEWS

In 2006, WA Stephenson (a local general contractor) was awarded a project to retrofit two Fontaine 1800mm sluice gate valves installed at Hamilton waste water treatment plant, Ontario, Canada.

RETROFIT CASE STUDY: City of Hamilton, Ontario, Canada
Author: Chris Bone - President, Rotork Controls (Canada) Ltd.

Motorising these valves became necessary due to the increasing safety concerns with operators having to climb portable ladders to access the manual hand wheel and clutch release; since the original installation in 1996 this had become a common practice. On the original project, costs had to be minimised, therefore the City of Hamilton purchased manually operated valves. Since then safety standards have been improving every year to a point that this is no longer a desirable practice. Many of the water and waste water plants across Ontario are faced with similar challenges each year.

The City of Hamilton provided a conceptual idea to the contractor where they planned to install an electric actuator mounted to the existing IB7 gearbox with a remote control panel and chain-wheel. Rotork and two competitors were approached to offer a cost effective solution to this problem and bids were submitted by all three companies. Rotork won the order based on product quality and retrofit experience. After receiving the order

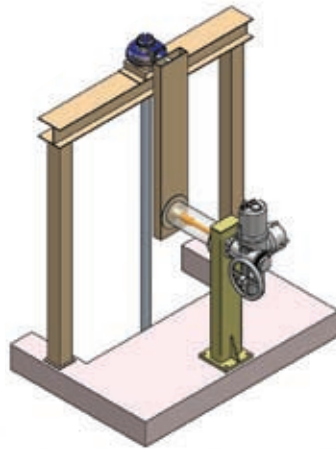

Rotork's proposed retrofit solution

in November 2006 Rotork's John Favaro visited the site to assess the situation and it became clear that the contractor's plan was not the only option available as there were still safety concerns with an actuator installed 12 feet above ground. This would not yield any operating efficiency improvements and would only slightly reduce the safety concerns; therefore an alternative was needed. This is where we could apply our extensive knowledge of retrofit solutions, gained over the past 15 years in a marketplace that



The finished actuated installation

has an estimated installed base of 65,000 actuators. The challenge in providing a solution was to use the existing sluice gate equipment in a way that would not stress the chain drive and frame beyond the specified capabilities, Fontaine were contacted to determine what the torque limitations would be for the equipment.

A very conservative safety factor of 50% was used to ensure that 170 ft/lbs of torque produced by the IQ25 115rpm actuator would not cause damage. Although this solution

would cost more than the original proposal the contractor approved the increase and accepted the drawings issued for review. The equipment was delivered to site and the contractor installed two units as per our instruction. A Rotork Technician was despatched to commission the units and train the operators how to safely use the new installed equipment. There is a very good possibility that this design will become a solution for the many sites throughout Eastern Canada that are faced with similar challenges.

COMPANY NEWS

Rotork website gets smart new look and more user-friendly features

The all-new, easy to navigate Rotork website, offering a total resource for global actuation solutions, is now live.

The website has been completely redeveloped to provide an easy to navigate, simplified structure with comprehensive sections on each of the Rotork Divisions as well as clear information on our entire range of products and services.

New features include:

- Improved search facilities for documents.
- New searchable archive of news stories from around the world.
- All-new CVA control valve actuator section including animated explanations of key features.
- Searchable global vacancy database.

More innovations and developments are in the pipeline and these will be regularly featured in future issues of Rotork, but in the meantime it's always worth keeping an eye on everything Rotork at: www.rotork.com



Home page (left) and CVA home page (top) from the all-new Rotork website

Rotork actuators with Pakscan in Saudi Arabia's major airport expansion project

Rotork IQPro intelligent electric actuators have been selected for a major expansion project at the King Abdul Aziz International Airport (KAIA) in Jeddah, Saudi Arabia.

The General Authority for Civil Aviation (GACA) plans a significant development of the airport over the next five years that will enable the facilities to accommodate 35 million passengers. Included in this, a new state-of-the-art terminal with 74 jet bridges will receive aircraft of all sizes, including the 555 seat Airbus A380.

The Airfield Facilities Upgrade is the first phase of the development programme, for which Rotork is supplying 120 IQPro intelligent electric valve actuators to Cameron Valves for the control of double block and bleed valves installed on the hydrant refuelling network for the A380. The actuator orders include Rotork's latest Pakscan P3 two-wire digital bus control system, which is particularly advantageous in the spacious environments associated with an airfield, where the distance between the actuators in the field and the centralised



The East Runway at the King Abdul Aziz International Airport (KAIA) in Jeddah, Saudi Arabia

control rooms can be measured in many kilometres. During contract negotiations Rotork was able to successfully propose the Pakscan solution as an alternative to the Modbus system originally requested, which would have encountered serious restrictions due to the long cable runs involved. Currently, two Rotork Pakscan master stations have been ordered to control and monitor actuators and associated equipment on the refuelling installations. Rotork's order, which is part of a contract awarded on a design and build basis to Almbani General Contractors, was won following a series of meetings between

Almbani General Contractors and Rotork's Middle East Regional Office in Abu Dhabi.

Rotork's agent in the Kingdom of Saudi Arabia, Al Hugayet Trading Establishment, will be supporting the installation, which will be commissioned by Rotork's Service Centre in Damman.

Almbani General Contractors' contract consists of the upgrading of thirty-year old airfield facilities, extending the runway to 4000 metres, widening all shoulders to accommodate the Airbus A380 and building a new 270,000 sq. metre apron for the Hajj Terminal.

The Airfield Facilities Upgrade is the first phase of the development programme, for which Rotork is supplying 120 IQPro intelligent electric valve actuators to Cameron Valves for the control of double block and bleed valves

High cycle duty at Lyon St. Exupery

Rotork France Sales Manager Didier Joanny reports on the unfailing reliability of an IQT actuator in constant use at the Lyon St. Exupery Airport.

In March 2006 the actuator was installed on a 150mm butterfly valve in the airport's cooling plant, on a water circuit that is used to reduce the nitrate levels in accordance with French legislation. As a result the valve is cycled several times every hour. A counter fitted during the installation registered over 150,000



Counter fitted during the installation

cycles without failure by the time that the actuator was to be upgraded with a new IQPro model in July 2008. Maintenance Manager Pierre Salmaso explains: "We chose the Rotork actuator on the advice of our



IQT actuator installed on a 150mm butterfly valve in the airport's cooling plant

local supplier, who told us about the high quality of the Rotork product. We had plenty of reliability problems with another manufacturer's actuator previously used, which had been replaced three times in five

years! We are so pleased with the performance of the IQT that we have now ordered three more to operate 250mm butterfly valves on our borehole supply system."

PEOPLE NEWS

Sporting Lucca leads the way

Football, cycle racing, rally cars - when it comes to sharing work with sport, Rotork's Lucca factory is in pole position.



Winners of the "Cup of Mulini" local competition, the football team also walked away with the trophies for best goalkeeper and top goal scorer



Meanwhile, the Rotork Lucca cycle team - now in its seventh year - came a very respectable third in the "Industry Trophy" competition



Not to be out-done, the newly-formed Rotork rally team entered the 43rd Rally Cup of Lucca and achieved fifth place in their category at the first attempt

COMPETITION CORNER

Remote Control in *shocking experience* at Eurodisney!



Catastrophe Canyon is a spectacular disaster feature in the Eurodisney Studio Tram Tour

Remote Control Area Sales Manager Arjan Jacobs recently had a shocking experience when he visited Eurodisney and then discovered that his own company's actuators were partly responsible.

Taking the Studio Tram Tour at the Disney park, his tram was suddenly detoured into disaster at Catastrophe Canyon and subjected to the effects of earthquake, fire and flood!

Continuing his journey, eagle-eyed Arjan spotted Remote Control actuators controlling the flow of the flood water to spectacular effect on this 'moving' experience.

If readers have any applications to match this unusual example, please email brief details to ftpublisher@aol.com marked for the attention of 'The Editor'.

We will publish the best entries and reward the senders with a 'spectacular' Rotork prize!



Remote Control actuators controlling the flow of the flood water

For more information on ROTALK articles and features contact Nicky Skinner at ROTORK Bath: +44(0)1225 733200 email: nichola.skinner@rotork.co.uk



UK head office
Rotork Controls Limited, Bath
tel 01225 733200
fax 01225 333467
mail@rotork.co.uk

USA head office
Rotork Controls Inc, Rochester
tel (585) 247 2304
fax (585) 247 2308
info@rotork.com

Rotalk is published and printed by Rotork Controls Ltd. in the UK.

www.rotork.com