

# rotalk 32

## Rotork innovation assists automation in the water industry

### Also inside:

#### Contract News

Sub-sea actuator is largest so-far for Lucca

#### Product Focus

CVA delivers reduced maintenance and increased accuracy

The CVA control valve actuator receives a prestigious  
'2009 Flow Control Innovation Award' - Page 8

# Rotork assists high-tech upgrade at sewage treatment plant

**The Wessex Water sewage treatment works at Swanage utilises state-of-the-art membrane bioreactor technology to produce high quality effluent that exceeds EU standards and is cleaner than the sea into which it is discharged.**

Now nearing completion, a major plant upgrade at the site is introducing automation and energy saving measures, whilst increasing the size of the membrane treatment plant to provide spare capacity for future demand. Central to the upgrade, Profibus network-enabled Rotork IQT intelligent electric actuators have been installed to operate butterfly and plug valves on new pipework throughout the plant.

Swanage STW treats sewage for a population of around 10,000 which can more than double when the area is busy with holidaymakers. Following preliminary screening and grit removal, sewage enters Kubota membrane plants installed in six large tanks for biological treatment and disinfection. The pores in the membranes are so small that they can prevent microscopic bacteria and viruses from passing through. The upgrade involves increasing the number of membrane packs in each tank to thirty-six, thus considerably increasing the treatment capacity without exceeding the confines of the existing works' footprint. Automation of the treatment process also enables it to run with increased efficiency and reduced energy consumption. On each of the membrane plants, the Rotork IQT actuators operate inlet isolation and outlet modulating valves for the sewage, together with air, sodium hypochlorite and wash water injection valves. Additional IQT actuators control permeate isolation valves used for automated sequential flushing to maintain membrane efficiency. In total, fifty-one actuators are installed on each tank to provide



One of the Rotork actuator diagnostic touch screen HMI displays on the site's SCADA system.



SCADA mimic screen diagram showing actuator status on one of the membrane bioreactors.



automatic sequencing of the sewage treatment, membrane cleaning and backwashing processes.

Fourteen Profibus-DP two-wire networks link the actuators to PLCs in the site's central MCC. These are controlled by a PLC and SCADA system written by Wessex Water's in-house Automation Team. The control PLC is a twin CPU configuration, with one dedicated to the control and monitoring of more than 300 actuators, whilst the other runs the complex automation process, resulting in the collection of control, status and full diagnostic data from each actuator, without any PLC speed or memory limitations.

Diagnostic information is available, locally at the valve or nearby HMI, on the site SCADA system and at the regional operation centre at Bath. Remote diagnosis is a cost effective method of maintenance and service because the right operational staff can be sent to site when required.

With the high level of process automation enabled by the Rotork actuators, come the added benefits of process integrity, auditability and highly reliable and accurate process control. Running costs are expected to reduce due to more effective control of the plant, saving electrical power, cleaning agents and water. The effective

use of Profibus technology allowed significant installation savings in cabling, terminations, PLC hardware and labour.

The Damar Group is the principal contractor for mechanical and electrical installation at the Swanage upgrade project, including the on-site fabrication and installation of pipework and actuated valves. The project manager is Wessex Engineering and Construction Services and the design consultant is Mott MacDonald. The Rotork actuators have been supplied in accordance with the framework agreement that the company holds with Wessex Water.

**rotork®**  
Controls

**rotork®**  
Fluid Systems

**rotork®**  
Gears

**rotork®**  
Site Services



**rotalk<sup>32</sup>**

INDUSTRY LEADING VALVE ACTUATION  
NEWS FROM THE WORLD OF ROTORK

**INTRODUCTION:**

Rotork assists high-tech upgrade at  
sewage treatment plant.....2

**CONTRACT NEWS:**

Rotork contract stories from around  
the world.....4, 6, 10 & 11, 14 & 15, 16

**ENVIRONMENT NEWS:**

Rotork actuators at the centre of one of  
the UK's most successful environmental  
regeneration schemes.....5  
Intelligent valve actuation at Severn  
Trent Water's "beacon project".....7

**PRODUCT FOCUS:**

CVA in Focus.....8 & 9  
Enhanced Profibus Device  
Type Manager.....18 & 19

**COMPANY FEATURE:**

Feature on Site Services.....12 & 13

**COMPANY NEWS:**

New facilities and expanded production.....17 & 20

## CONTRACT NEWS

# Degrémont selects Rotork for state-of-the-art valve control at the Llobregat desalination plant

**Rotork IQ and IQT intelligent electric actuators with Rotork Pakscan P3 two-wire digital control provide state-of-the-art valve control throughout the Llobregat desalination plant.**

More than 400 actuators have been installed, controlled by eight hot-standby Pakscan P3 master stations.

The Pakscan master stations provide a direct interface for each of the actuators controlled on its secure, two-wire loop with the Siemens Step 7 PLC that operates the sequence of the recently opened plant's processes.

The Rotork actuator and Pakscan valve control package was specified by the plant's engineering contractor Degrémont following a thorough

analysis of all available actuator control bus technologies including Profibus, Modbus and DeviceNet.

The benefit of having a fully redundant system on a single loop technology made an important contribution to the final decision.

The excellent level of support available locally from Rotork, including more than seven fully trained service engineers, was another key factor recognised by ATLL, the plant operator and the main water supply company for the city of Barcelona and the Cataluña area.

The combination of Rotork IQ actuation technology and Pakscan P3 two-wire control offers many benefits for the operator.



All photography courtesy of InfoEnviro.

### Benefits include:

- A capacity for up to 240 actuators on a single 20km, 2-wire loop.
- Built-in diagnostic features including performance data and fault location indication.
- Direct reduction in cable and engineering costs.
- System fault tolerance to ensure continuous operation even if a fault exists.
- Increased information flow, providing improved asset management.
- Lower commissioning costs due to faster, easy installation.
- Web browser included as standard.
- Dual host communication ports on both Ethernet and serial data lines.
- Intermediate control point that can be used during plant maintenance.

Rotork IQ and IQT intelligent electric actuators embody industry-standard features for reliable and economical valve control.

These include non-intrusive set-up and adjustment, double-sealed IP68 watertight enclosure, data-logger and comprehensive software tools for plant records and valve diagnostics and versatility encompassing isolating, modulating and multi-port applications.

# Rotork actuators at the centre of one of the UK's most successful environmental regeneration schemes

**To the casual observer, it looks like a set of modern sea locks and outfall penstocks such as can be seen all around the coast of the UK. But, as part of one of the country's most successful regeneration schemes, it is much more than that.**

The Cardiff Bay Barrage – a major engineering project that took over five years to build at a cost of £220 million – is also a highly sophisticated environmental protection mechanism designed to regulate the water level in the 500 acre fresh water Cardiff Bay and to isolate it from the sea by preventing the ingress of sea water.

The pipework design comprises of a man-made sump in front of the locks on the bay side of the barrage which leads down to a 1200mm pipe installed beneath the barrage in order to return to the sea the salt water introduced to the bay by lock activity. Two branches from this main pipe lead to Locks 1 and 2, enabling the salt water to assist the filling of these locks at times of low river flow into the bay. The branches can also be

used to transfer water between the two locks as circumstances dictate.

The IQ actuator on the main pipe valve is fitted with a current position transmitter to enable the valve to be opened at percentage increments in order to control the flow of salt water from the sump. The configuration of the three other actuated valves in the network can be altered to fill either or both of the locks or transfer water between them. Under PLC control, the actuated valves are remotely operated from the Salt Water Panel in the Barrage Control Room. Data from floating analysers in the bay assist in gauging the level of salt water in the sump, enabling the operators to open the valves as required and divert the salt water into the appropriate destinations. Because Cardiff Bay is now a recreational and

*"For over a decade, since the barrage was first completed, the enormous butterfly valves in the underground pipework network that controls the environmental protection process have been reliably operated by Rotork IQ actuators."*



*Lock Keepers Tony Hughs and Sam Hartley on duty with the Public Address Panel in the Barrage Control Room.*



*The landward view of the sea locks from the Barrage Control Room.*



*From the other side of the Barrage Control Room the five sluices that regulate the water level in Cardiff Bay can be seen, with the fishpass beyond and the bay in the background.*

environmental asset, the frequency of actuator operation fluctuates from season to season and from day to day. In busy periods there can be over 150 boat movements through the locks during a weekend. Meanwhile the actuator on the main inlet control valve is constantly in operation throughout the year.

In an adjacent area of the barrage a fishpass is installed to allow the uninterrupted travel of migratory fish from the Severn Estuary to the bay and to the important Taff and Ely salmon rivers that feed into it. Like the locks, there is more to this installation than meets the eye. Designed to assist the ongoing scientific study of fish health in a changing environment, the fishpass is equipped with six Rotork IQ actuators to control various penstocks and screens leading to different areas of the installation, depending on tidal conditions.

The actuators operate penstocks to allow fish in and out of a fishtrap, where they are examined by the



*Senior Maintenance Engineer Richard Parker with two of the Rotork IQ actuators on the pipework branch leading to the two sea locks.*

Environment Agency, through a gravity attraction area, which allows fresh water to flow out of the barrage to draw the fish towards the fishpass, and through the Denil pass, man-made rapids that enable the fish to travel 'uphill' into the bay. An additional IQ actuator operates a screen that prevents debris from travelling through the fishpass. The operation of the fishpass actuators is controlled by a SCADA system in the Barrage Control Room, which is backed up by a motor control centre in the unlikely event of a fault.

## CONTRACT NEWS

Royal Navy warships are being equipped with the latest Rotork intelligent electric valve actuators for rapid reaction fire protection duties.

## Rotork actuators specified for critical valve duties on Royal Navy frigates



The Type 23 frigate is known as the backbone of the modern Royal Navy. Photograph Crown Copyright/MOD, image from: [www.photos.mod.uk](http://www.photos.mod.uk)

“Rotork IQTPro actuators feature a double-sealed IP68 watertight and temporarily submersible (7 metres for 72 hours) enclosure for maximum, maintenance-free reliability in challenging environments.”

The Rotork IQTPro actuators have been specified to replace existing pneumatic equipment on butterfly valves in sprinkler systems on Royal Navy Type 23 frigates.

The Rotork actuators will be remotely controlled and operate from a secure 115 VAC power supply, facilitating an immediate response to potential fire or explosion hazards. In addition to increasing the integrity of the system, the switch to electrical actuation reduces the ship’s company’s service and maintenance workload and eliminates the current need for back-up air cylinders.

Data loggers in every actuator record a commissioning log and

historical record of subsequent valve operations, including valve torque profiles.

This information can be downloaded and analysed on a PC running Rotork IQ-Insight software to identify any future potential problems, enabling maintenance, if required, to be organised with maximum efficiency. They have also successfully undergone seismic testing to establish resistance to explosion-related shock treatment.

Sixty-nine IQTPro actuators have been ordered for the upgrades by the Ministry of Defence. Installation will be carried out during the vessels’ dockyard refit programmes.

## Middle East pipeline contract includes ‘point of control’ security for Rotork valve actuators

**Rotork IQPro intelligent electric valve actuators with Pakscan two-wire digital control networks have been ordered for a strategic new pipeline project in the United Arab Emirates.**

The Abu Dhabi Crude Oil Pipeline (ADCOP) will provide a vital export alternative to the Hormuz Strait “bottle neck” for the Habsham Oilfield, which is the collection centre for the bulk of Abu Dhabi’s onshore oil production activity.

Rotork’s success in the award of this contract has been assisted by the ability of the IQ actuation and Pakscan control package to meet customised demands for increased operational security. Modifications have been incorporated to enable the control system to identify and

eliminate any potential on-site interference and unauthorised valve operations. To achieve this requirement, the status of the ‘local/remote/stop’ operating switch on every actuator on a Pakscan loop is indicated at the master station controlling that loop, where it is also accessible by the supervisory controller. The digital state of this signal changes when the switch is moved to the ‘local’ or ‘stop’ positions, but the actuator cannot be operated locally and remains in remote control, where it can be operated over the network. At this point the supervisory controller can decide whether or not the local control request is authorised and, if it is, put the actuator into the control status required. In this way, the risk of unauthorised on-site operation is



permanently eliminated, providing increased security and protection for the pipeline network. Rotork has received orders for several hundred IQPro actuators on the project, controlled by five ‘hot-standby’ Pakscan master station loops. The actuator-dedicated Pakscan digital control system is particularly well suited to pipeline applications, since up to 240 field units can be supported by a single master station, controlling a two-wire network with a maximum length of 20 kilometres, without repeaters. Pakscan’s redundant field communication path technology provides complete cable fault protection and immediate

identification of any break in the network loop. Such an event causes no interruption to the operation of the field units on the network.

Rotork’s client on the project is the Abu Dhabi Onshore Company (ADCO) and the China Petroleum Engineering & Production Company (CPECC) is the engineering contractor. The completed ADCOP project will include a 370 kilometre, 48 inch pipeline, capable of transporting 1.5 million barrels of crude oil per day to Fujairah on the UAE’s eastern coast, where a tank farm and export facilities are also being constructed.

**Severn Trent Water's Minworth sewage treatment works, which serves around 1.75 million of Birmingham's population, is undergoing a major modernisation project that will improve the quality of the water put back into the River Tame and significantly upgrade the work's facilities, improving the quality of the 1bl (one billion litre) daily treatment capacity.**

The £145 million project is being handled by an alliance comprising Severn Trent Water, North Midland Construction Nomenca and Biwater, with Pick Everard as consultants. It will create one of the world's most efficient and technologically advanced large scale treatment works.

Tony Wray, chief executive officer of Severn Trent Water, has praised the scheme as a "beacon project", adding that the 30-strong supply chain should be proud of the numerous achievements at Minworth. As a member of this supply chain, Rotork has supplied over 250 Profibus network-enabled IQPro intelligent electric actuators for valve control throughout the new and refurbished plant areas.

## Intelligent valve actuation at Severn Trent Water's "beacon project"



Many of the actuators are installed on the new eight-lane inlet works, the new 22 primary settlement tank island and the enlarged activated sludge plant.

In all areas Rotork IQPro multi-turn actuators operate penstocks to control the flow through the works, whilst on the activated sludge plant, IQTPro direct drive quarter-turn actuators are also installed on the air flow control valves that regulate the introduction of air into the treatment tanks.

The actuators are linked on fully redundant Profibus field networks to Allen Bradley PLC platforms at intelligent motor control centres (iMCC's) throughout the site.

These interface with the site's Rockwell SCADA system, which is accessible at local HMI terminals at key site locations. Feedback from sensors throughout the plant is used to automatically operate the actuators to account for fluctuations in flow, caused, for example, by storm conditions, and to enhance

the efficiency of operations. The software for the SCADA system has been written by Safronics Controls and the whole network has been designed to provide extended information and historical trending for energy management and condition monitoring.

Assisting this function, data loggers in the Rotork actuators store a commissioning 'footprint' of valve operating torque and a torque curve for all subsequent valve operations. This data can be downloaded and analysed with Rotork IQ-Insight software in order to identify and plan valve maintenance requirements. The technology assists the optimisation of plant utilisation and eliminates the need for over-cautious maintenance scheduling.

As a further assistance to maintenance, all the actuators utilise Rotork's 'bumpless' Profibus interface module, which enables individual motorised valves to be disconnected without disrupting communication with the other devices on the network.

The new Rotork actuators join hundreds that are already installed at Minworth. Most have been fitted during previous modernisation programmes at the site and supplied through the long-standing framework agreement that Severn Trent Water has with Rotork.



## Reduced maintenance and improved accuracy in New Hampshire

**A 400 megawatt power plant in New Hampshire, which burns both natural gas and low-sulphur fuel oil, has recently installed a Rotork CVA electric control valve actuator to help to reduce maintenance costs and improve accuracy in a demanding outdoor fuel oil flow control application.**

The Rotork quarter-turn actuator (model CVQ 1200) in a NEMA 6 enclosure was installed in June. It replaced a traditional I/P positioner and spring diaphragm pneumatic actuator operating a 6-inch class 150 ball valve. The valve and actuator are located outdoors and control the flow from a fuel oil day tank to fuel oil pumps.

The valve modulates frequently to maintain the correct flow as the load on the unit changes. Both the New England weather and the accurate control of oil flow pose rigorous challenges. According to plant personnel, the traditional pneumatic spring-diaphragm actuator required frequent maintenance and was prone to accuracy problems.

Since its installation, plant personnel report they are impressed with the CVA's performance. Specifically, they report that the maintenance and accuracy problems have been resolved. Furthermore, the plant's instrument and control technicians and supervisor liked how easy the CVA was to set-up and calibrate.



## CVA in Focus

**The CVA control valve actuator has had an excellent year, delivering impressive performance in challenging applications and receiving a prestigious '2009 Flow Control Innovation Award'.**



The award programme is an annual competition sponsored by Flow Control magazine and recognises the year's most compelling advances in fluid-handling technology.

This year, twelve products representing a wide-range of different fluid-handling technologies received the award. Winners were selected on the basis of reader votes and Flow Control staff input.

The award was presented to Rotork at the 2009 ChemShow, held on Nov 17-19 at the Javits Convention Center, New York City, by John Harris, Publisher of Flow Control magazine. Accepting the award for Rotork was Chris Warnett, Sales and Marketing Director, Rotork Process Controls.

Rotork CVA electric control valve actuators provide a major technological advance in precise operation HMI capabilities and fail-to-position protection, as well as significant energy savings. They are available in linear and quarter-turn versions, are easily integrated into most process control environments, eliminate the need for costly air supplies and can be specified for single-phase AC or DC electrical supplies. CVA actuators provide extremely precise control valve operation with repeatability and resolution performance at <math><0.1\%</math> of full scale. In addition, they include, as a standard feature, wireless Bluetooth communication technology that can be used for quick and easy actuator set-up and adjustment.

All Rotork CVA actuators incorporate a data logger, which provides an extensive record of such operational and maintenance-related information as valve torque profiles, dwell times, and relevant statistical information. They utilise a built-in super-capacitor that provides an advanced, programmable method for fail-to-position protection.



Chris Warnett accepting the award from John Harris, Publisher of Flow Control magazine.



# “Fit and forget” solution for sticky valve problem



**The Rotork CVA electric control valve actuator has proved to be a ‘fit and forget’ solution for a challenging application in the harsh environment of a UK coal-fired power station.**

The CVA actuator has replaced a pneumatic actuator and I/P convertor on one of the fuel oil purge lines for the burners at the RWE Tilbury power station. The power station is coal fired, but oil is used to light and start the burners on the station’s three boilers. Installed over eighteen months ago, the CVA has proved to be a ‘fit and forget’ solution, requiring no maintenance.

In particular, it has been noted that there is never a problem with sticking and overshooting, which happens with the pneumatically actuated valves on the same duty when the valve has been closed for a while and the oil congeals on the seat and plug.



In addition, the pneumatic actuators require regular maintenance, sometimes including the replacement of damaged diaphragms, all of which is eliminated through the use of the CVA.

RWE’s Kevin Wade, who is in charge of the fuel oil purge line installation at Tilbury, confirmed that “the CVA has worked above all expectations and I would be pleased to use it on other areas of the plant.”

It is estimated that there are over 500 pneumatically operated control valves in a typical fossil-fuelled power station, so the use of the CVA as an all-electric alternative presents the potential for huge savings in maintenance and repair times.

The other significant benefit of the CVA is the lower use of energy. Because pneumatically operated control valves rely on an instrument air supply, compressed air has to be constantly available to operate the actuators even when they are resting at a fixed set point. The losses due to leakage, compression and transmission in an air supply system means that approximately half the input energy is lost. The CVA, being a high efficiency electric actuator, uses little energy when it moves, and the losses associated with a pneumatic supply are eliminated.

## Carbon pitch production in Australia

**Rotork Australia has recently installed two CVA-1200 rotary actuators at the Koppers Inc. continuous tar distillation facility in Newcastle, New South Wales.**



Koppers is a leading provider of carbon pitch compounds and wood treatment products, with twenty-eight facilities in Australia, Asia, Europe and the USA.

Carbon pitch is an important raw material in the production process for aluminium and for the production of steel in electric arc furnaces. Crude tar is shipped to Newcastle from steel making facilities at Whyalla (South Australia), Port Kemble (NSW) and other overseas locations.

The first CVA actuator installed is on the wharf hot oil line back pressure valve, which keeps the pitch warm and liquid. Replacing an obsolete actuator, the CVA controls the back-pressure from a 4-20 mA signal and must fail open on power failure.



The second unit is on the plant’s air line, operating a two-inch butterfly valve that closes on low air pressure via a 4-20 mA signal, or in the event of power failure.

## CONTRACT NEWS

## Rotork actuators with thrust compensators assure reliable operation of high temperature chemical valves

**A new production plant ordered by one of Japan's leading chemical companies has been equipped with Rotork IQPro intelligent electric actuators that are specially designed to assure the reliable performance of valves subjected to operation in high and dramatically fluctuating temperatures.**

The new plant, which is being installed by Mitsui Chemicals Inc. at Ichihara, uses Mitsui's proprietary technologies to manufacture specialised chemical products. During the process the gate valves operated by the Rotork actuators will be handling gases at temperatures between 300 °C and 650 °C.

In such severe operating environments there is a potential danger that a closed valve could become jammed in its seat as a result of the thermal expansion of its valve stem. In extreme cases this can cause the valve stem to distort or the valve to break. Conversely, a valve that is moved to its closed position when at a very high temperature can be prone to seat leakage if it subsequently cools down.

In order to overcome these potential problems on eighteen of the valves, Mitsui Chemicals accepted the valve vendor's recommendation to use Rotork IQPro actuators equipped with a specially modified valve stem nut design.

The design – known as the thrust compensator – was originally developed to overcome critical high temperature applications in the nuclear power generation industry. The thrust compensator consists of a spring loaded stem nut that will absorb any expansion or contraction caused by temperature fluctuations without affecting the position of the closed valve stem. The construction of the device is also designed to ensure that the positive valve shut-off demanded in critical applications is not compromised.

The Rotork thrust compensator design solution has proved itself in many severe service applications. As a result it is generally specified as standard for high temperature operation by the manufacturer of the gate valves supplied for the Mitsui Chemicals project.

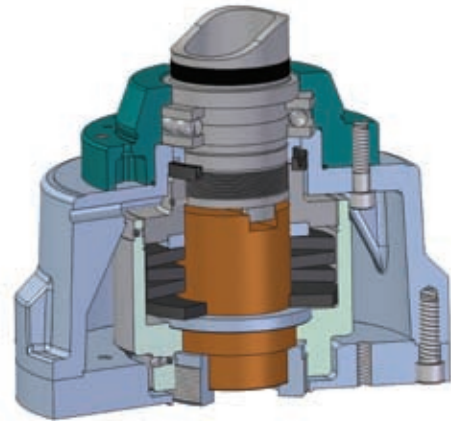

*Cutaway diagram of the thrust compensator, showing how the stem nut is supported on springs to allow expansion and contraction in response to thermal changes without altering the valve position.*



*Rotork IQPro valve actuators with thrust compensators installed on the new Mitsui Chemicals plant.*

**Forty-two Rotork AWT and Q range electric valve actuators have been installed in a new clean water distribution network constructed for local villages in the Qattine Azar area of the hills of Beirut in the Lebanon.**

The project, encompassing two pumping stations and associated pipelines, has been carried out in its entirety for the local water municipality by Rotork's agent in the country, Arison s.a.r.l.

The successful completion of this significant improvement to the local infrastructure is expected to herald similar projects in the future.

## New clean water distribution network constructed for local villages



*Rotork AWT actuators installed at the Qattine Azar clean water distribution network.*

# Contract news from the Middle East

**A snapshot of contract activity in the Middle East reveals significant new projects involving the improvement of the infrastructure of the area – inside and outside of the oil and gas industries – including:**

## The Regent Emirates Pearl

The Emirates Pearl, a forty-seven story tower hotel in Abu Dhabi. This \$134 million project will have 352 hotel rooms, 104 apartments and an atrium with five restaurants, a gym, spa and shops.



The Regent Emirates Pearl, Abu Dhabi.

Other features include two Presidential suites and a private penthouse with a helipad.



Fifty Rotork IQ actuators have been ordered for the district cooling plant associated with this stunning building.

## Al Maktoum International Airport

In Dubai, the Al Maktoum International Airport, located at Jebel Ali, is planned as the largest passenger and cargo hub in the world, comprising six parallel 4.5 km runways, three passenger terminals and sixteen cargo terminals.

Rotork IQ actuators have been ordered for the hydrant refuelling systems for the giant Airbus A380 airliners, a similar application to the recent Rotork contract at the New Doha International Airport.

## Al Seeb Sewage Treatment works

Another high-tech project in a completely different industry, the Al Seeb sewage treatment works in Muscat has placed the first orders for IQ actuators. Success here follows Rotork's activity at the Al Ansb sewage treatment works, also in Muscat, where more than 300 IQ actuators with Foundation Fieldbus network connectivity have been installed and are undergoing final commissioning.

## Yemen LNG plant

In the oil and gas industry, a huge project involving the first LNG plant in the Yemen is nearing completion. The project, which comprises two LNG production trains and export terminal, utilises a large number of IQ actuators and Pakscan digital control systems. The plant is now in the final commissioning stage with Rotork technicians assisting the contractor on-site. Graeme Oliver from Rotork's training department has also visited

the Yemen to conduct product training for LNG staff as a part of Rotork's total package of supply. Mr. Hassan K. Serhan from Rotork's trading partner, Safir Services Ltd, has been at the centre of co-ordination activity between the client and contractor.

The Yemen LNG plant is the country's largest industrial project. Its exports will offset the effects of falling oil output and help to boost economic growth in the country.

"The project, which comprises two LNG production trains and export terminal, utilises a large number of IQ actuators and Pakscan digital control systems."



The Yemen LNG plant.



Al Maktoum International Airport.

FEATURE ON **SITE SERVICES**

# Rotork Holland reports **brisk valve actuation activity** at enlarged workshop facility



**Photographed at the recently enlarged Rotork workshops in Holland, these ball and butterfly valves were supplied by the valvemaker for the fitting of Rotork IQ intelligent electric actuators and Rotork Gears worm gearboxes.**

The completed and tested valve packages were then shipped to Krohne Oil and Gas for installation on a metering skid project.

The contract is an example of the increased volume and throughput of actuation upgrade, repair and new project work that the workshop expansion programme at Rotork Holland has allowed.

Amongst the improvements, the increased workshop size has more than doubled the number of actuators that can be fitted to valves at the same time. The five tonne overhead crane has been extended

in range to facilitate direct truck loading and unloading, whilst two new beam-mounted 250kg cranes now serve the workbenches and a new actuator test rig, eliminating any need to manually lift and carry actuators and valves.

These improvements have been introduced hand-in-hand with the implementation of new and more efficient work practices, applicable to Rotork's virtually entire range of electric and fluid power valve actuators.

Whilst the significantly sized Krohne Oil and Gas contract was in progress, the workshop was also taking care of a separate order to fit double block and bleed valves with Rotork IQ electric actuators. The completed and tested valve packages have been inspected by the customer and forwarded to the Vopak Europoort tank farm terminal as part of a major upgrade project at the facility.



*Photographed at the PTT Gas Block Valve Station PN1 on the Bangplee to Saraburi natural gas pipeline, Rotork Thailand's Site Services Team is supervising a local contractor during the installation of a Rotork GO gas-over-oil actuator on a new emergency shutdown valve.*

The Rotork GO actuator (model number GO-100S-140F/D1) is designed to immediately shut the 12 inch, ANSI Class 300 ball valve if a large pressure drop, indicating a leak in the pipeline, is detected. The actuator uses the pressure of stored gas from the pipeline itself to operate the valve and is equipped with accumulators to allow a minimum of two operating cycles without replenishment. In this way the actuator can always operate the valve when commanded by the automatic line break system, irrespective of the prevailing pipeline and power supply situation at the time of the emergency. Operating speed is inherently as fast as conventional hydraulic actuation.

At the centre of the Rotork GO actuator design, a multi-function manifold block integrates the gas and hydraulic functions to meet the specific demands of each application. These can include altering the speed of valve travel to enable very fast operation during an emergency, with much slower operation to prevent damage to the pipeline during routine operations or partial stroking maintenance programmes.

# Rotork Thailand's Site Services Team **on the GO** at new pipeline installation



An additional Rotork safety feature is the TLD torque limiting device, which measures and limits the differential pressure between the gas on the supply side and the oil on the return side of the accumulators to protect both valve and actuator from damage caused by too much torque. Hydraulic manual override is also provided as standard. Features such as these have proved to be attractive to end user

operators and have helped Rotork Singapore to sell over sixty GO units during the last year. As illustrated by this application, customer support in the country of final installation is also an important contributor to the success of Rotork's products. This actuator was inspected by engineers from PTT (Petroleum Authority of Thailand) at Rotork Thailand's workshop, prior to site installation

under Rotork supervision. The PTT Gas Bangplee to Saraburi pipeline is 99 kilometres in length and a central element in Thailand's growing natural gas transmission network.

Each block valve station on the pipeline network is equipped with a gas transmission control system, remotely supervised by SCADA systems at 24 hour-a-day operation centres.

## Maintenance and repair framework with **Scottish Water**



*Profibus enabled IQPro actuator.*

**Site Services in the UK has been awarded a framework agreement by Scottish Water for the mechanical and electrical inspection, maintenance and repair of installed valve actuators.**

Rotork has been a major supplier of new actuation equipment to Scottish Water for over thirty years, resulting in the installation of several thousand Rotork actuators throughout the Scottish mainland and islands.

In recent years this relationship has also been the subject of a framework agreement.

In many cases, the latest Profibus-enabled IQPro actuators have become the key components for automated plants and upgrades, the latest example being Glencorse Reservoir, where a new £130 million state-of-the-art water treatment plant utilising 160 actuators is under construction. With Rotork Site Services' record on maintenance and

repairs claiming a "95% first time fix", the new framework will facilitate improved asset management throughout the Scottish Water region, as well as providing swift access to a number of additional Rotork capabilities.

These range from installation and commissioning through to extended scope site projects, with full workshop-based support, including the provision of actuated valve packages and associated equipment.

# Sharq Third Expansion Project in Saudi Arabia

**Pictured at the Rotork Fluid Systems factory in Lucca are some of the large linear pneumatic actuators ordered for the Sharq Third Expansion Project in Saudi Arabia.**

In total, 112 of the actuators were ordered for the operation of gate valves in sizes between 34" and 30". The largest resultant actuated valve packages are over two metres in diameter and five metres tall.

Others are specially designed for cryogenic service. Rotork Fluid Systems supplied double-acting and

spring-return LP range actuators with a total value of US \$3.5 million on the project. The Sharq project will add a total production capacity of 2.8 million tonnes per annum of ethylene glycol to the Eastern Petrochemical Company's facility in Jubail, making it one of the world's largest petrochemical sites.

Foster Wheeler and Stone and Webster managed the engineering procurement and construction contracts and provided management, co-ordination and control of all phases of the project.



**Rotork Skilmatic EH electro-hydraulic valve actuators have provided a successful solution for the provision of reliable emergency valve operation on a slurry pipeline in one of the world's most arid, inhospitable and remote locations.**

The Atacama Desert in north-east Chile is traversed by an eighty kilometre pipeline owned by the mining company Compañía Minera del Pacifico SA. The pipeline carries iron slurry from the town of Copiapo to the port of Caldera, from where it is exported. The Rotork actuators have been installed at the UVS-1 emergency plant centre, half way along the pipeline and in the middle of the Atacama Desert. Here, the annual rainfall is a meagre 12mm and the ambient temperature fluctuates between -15 °C in winter and +40 °C in summer.

Three Skilmatic EH electro-hydraulic actuators have been installed to operate ANSI Class 1500 ten-inch ball valves. The actuators provide double-acting on-off control for the valves, under remote SCADA system supervision.

The innovative Rotork Skilmatic EH design comprises an integrated control module, a hydraulic manifold and a power unit consisting of a motor, hydraulic pump and reservoir. Protected by a waterproof, dustproof and explosion proof enclosure, the actuators' electronic functionality benefits from Rotork's IQ intelligent electric actuation technology, providing configuration, diagnostics,

## Solar powered actuators for slurry pipeline in the Chilean desert



*Close-up of one of the Rotork Skilmatic EH electro-hydraulic actuator installations. The hydraulic actuator pump and reservoir are mounted above the hydraulic cylinder, next to the integral control module. The lever in the foreground enables the actuator to be operated manually.*



*General view of the UVS - 1 emergency plant centre, showing the three Rotork Skilmatic EH electro-hydraulic actuators, back-up nitrogen tanks and the solar power panels.*

fault indication and position indication by means of a digital visual display and non-intrusive, two-way communication with a hand-held programmer.

The self-contained actuators operate from a 24 Volt DC supply, enabling an efficient, economic and environmentally friendly solar powered battery system to be used. The security of emergency operation is further enhanced at this site by back-up nitrogen tanks which enable each actuator to perform three valve strokes.

Gabriel De Visnyey, Rotork Fluid Systems Regional Sales Manager for Latin America, explains: "The Atacama Desert project is one of a number of remote pipeline applications which have recently adopted the Rotork Skilmatic EH solution. The features inherent in the electro-hydraulic design are ideal for remote installations and facilitate the use of renewable energy sources such as solar power whenever possible".

The actuators for the UVS-1 emergency plant centre were sold by Rotork's Chilean representative Ineco Ltda, who are providing local support. The procurement and construction contractor for the project is Constructora Belfi and the engineering contractor is Brass.

# Sub-sea actuator is largest so-far for Lucca

**Rotork Fluid Systems has supplied the largest sub-sea rack and pinion actuator ever built at the Lucca factory.**

Measuring over two metres high and five metres in length, the single-acting spring-return model number GSR-2-500-160F/CX actuator is designed to operate a 24 inch, ANSI class 900 sub-sea safety isolation ball valve (SSIV) for the Tuna Gas Gathering Project, off the coast of Egypt.

The hydraulically operated package incorporates a special gearbox and de-clutch system manufactured by Rotork Gears which enables the actuator's output drive to the valve to be automatically disconnected and reconnected, if necessary when maintenance is required.

In such an event, uninterrupted valve operating availability is ensured by a separate ROV (remotely operated underwater vehicle) connection to the gearbox. Complete valve control is also maintained by means of the ROV interface on the gearbox if the actuator is removed. This feature enables a single, interchangeable actuator to be used on two or more valves. The complete system has proved to be very reliable, with the potential to

achieve high levels of SIL approval. Diagnostic analyses are also available, enabling potential operating problems to be identified before they might occur.

Due to its considerable size, factory testing of the actuator demanded the construction of special equipment. In particular a tall frame was built in order to realistically simulate the ROV operation that would take place from the top of the installed valve skid, which is designed to prevent any damage to the valve from objects dropped into the sea or fishing activities.

Testing was assisted by new external crange installed at Lucca to handle the very largest of actuators in an area dedicated to sub-sea actuator testing.

The SSIV package will be installed on the export pipeline from the new Tuna platform to an existing pipeline connecting the TNW2 platform to the shore. A dedicated electro-hydraulic umbilical from the Tuna platform will control the actuator.

Together with a check valve installed upstream of the ball valve, the SSIV will prevent any gas backflow in the event of a pipeline or riser rupture in the close proximity of the Tuna platform.



The completed actuator and gearbox assembly, with its ROV connector.

**Rotork Fluid Systems has been awarded a contract to supply pneumatic valve actuators and packaged controls for a new offshore oil production platform located in the South China Sea.**

Wellhead Platform B (WHP-B) is a major component of the Su Tu Den Northeast (STDNE) Field Development, located in Block 15-1, offshore Vietnam.

Rotork is supplying forty-four GP and CP range pneumatic actuators for the on/off control of ball valves in sizes ranging from 2inch to 24inch. Included in the contract is a GP-200C-685A/C1 actuator to operate an 18inch, ANSI Class 1500 ball valve on a High Integrity Pressure Protection System (HIPPS). The WHP-B platform will be a normally unmanned installation and the safety-related function of the HIPPS will be to provide a failsafe back-up system to ensure the containment of

hydrocarbons in the event of pipeline or vessel overpressure. The HIPPS will protect the production manifold, pig launcher, pipeline and manifold from overpressure from the STDNE wells.

The first level of protection is the Platform Instrumented System, but if this is unavailable, the HIPPS is designed as an independent second level of protection that will detect an overpressure scenario and ensure that the STDNE production wells are isolated. Situated in Vietnam's Cuu Long Basin, the Su Tu Den Northeast Field Development project will extend existing offshore oil facilities in the area and deliver an additional 30,000 barrels per day when production starts in 2010.

## Offshore Vietnam actuation contract includes High Integrity Pressure Protection System



## CONTRACT NEWS

# Challenging application launches Rotork's compact subsea gearbox solution



The completed double block and bleed ball valve and DS gearbox package for the Nini East Field Project.

**A compact new design of subsea valve gearbox from Rotork Gears has provided a timely and successful solution to a challenging problem on a North Sea pipeline project.**

The development of the Nini East Field off the coast of Denmark by Dong Energy involves the construction of a new, unmanned production platform and a 7 kilometre subsea pipeline to the existing Nini platform. As part of the contract for the project, a UK valvemaker is supplying a Class 1500, six inch metal seated double block and bleed ball valve for a critical duty demanding zero seat leakage on liquid and gas duty.

Due to the specific constraints if the valve installation, the valvemaker's engineers were advised that access for ROV operation could only be possible from above the valve and no access from the sides could be permitted. In addition, there were restrictions to the allowable overall dimensions of the valve and gearbox package due to the surrounding fabrication.

Working closely with the valvemaker, Rotork Gears proposed a new gearbox design that met the size restrictions without compromising the technical performance. The new gearbox design, known as the DS range, proved to be the most compact solution available whilst manufacture of the two units required was achieved on a lead time that complied with the project requirements.

When installed, the high pressure valve package will be operating at a depth of 58 metres. The Nini East Field development is expected to extend the life of the Nini Field for at least another ten years.

## Rotork actuators for Saudi petrochemical plant

**Over two hundred pneumatic valve actuators have been ordered from Rotork Fluid Systems for the Saudi Kayan Phenolics Complex, a major component of the new Saudi Kayan petrochemical plant being constructed at Jubail Industrial City.**

Rotork CP and GP range scotch-yoke pneumatic actuators have been ordered for the operation of ISO Class 300 ball valves, ranging in size from 1 inch (25 mm) to 8 inch (200 mm). Valve duties include depressurisation, emergency shutdown and fire safety.

The Saudi Kayan petrochemical plant at Jubail Industrial City will have an annual chemical production capacity of 4 million tonnes.

As a part of this, the Phenolics (carbolic acid) complex will consist of a cumene unit, a phenol plant, a bisphenol facility and an acetone recovery unit.

Engineering for the plant is being performed by Spanish contractor Tecnicas Reunidas S.A.



A petrochemical complex in Al-Jubail Industrial City, Saudi Arabia.



# Fluid Systems factory expansion at Lucca



The Lucca factory warehouse area.

**Continuous global sales growth for Rotork Fluid Systems has been reinforced by a major expansion project at the Lucca manufacturing plant.**

The covered factory ground floor area has been increased by 40% to more than 11,000 square metres, whilst the total outside area has been increased to 23,000 square metres.

The expansion facilitates improvements in the layout of internal manufacturing plant

involving a new process flow resulting from the relocation of testing, packing, shipping and storage areas. In addition, a new area for first assembly operations has been created and five new gantry cranes installed, the largest with a 20 tonne lifting capacity.

A second 20 tonne gantry crane with towing equipment has also been installed outside, ensuring that the factory is well equipped to build and handle the very largest actuators, such as the model 350 scotch-yoke pneumatic unit.



The assembly area for large actuators at Lucca.

**Rotork Process Controls LA-2490 modulating electric actuators have been installed to improve the speed adjustment on the hydraulic drive scoops that control the supply of oil to the turbines at the Qing Huan Gao Power Station in China.**

The new units have replaced locally manufactured electric actuators that had limited modulating performance and lacked positional accuracy.

Operating from a 4-20 mA control signal, the LA-2490 actuators are linked to the scoop tubes by external linear drives. Moving a pick up scoop into the oil chamber allows oil to be drawn up the tube and into the working chamber of a turbine. A maximum amount of oil in the chamber results in the maximum speed output.



## Improved accuracy for turbine oil supply at Chinese Power Station

Withdrawing the tube from the reservoir chamber allows oil to return to the reservoir, decreasing the amount in the oil chamber and reducing the speed output.

The force required to push or pull the rods connected to the scoop tube can vary by a factor of 10 up to a maximum of 4.5 kN (1000 lbf).

Further benefits of the LA-2490 include a small footprint that can be mounted in any position, simple push-button set-up procedure, easy fine tuning in the field and a low cost of ownership.

## Network News

The latest news from Rotork's Systems Department involves significant user-friendly software upgrades to the Profibus open system protocol supported by Rotork actuators.



Images on this page, top to bottom: IQPro, EH actuator, ROMpak actuator, CVQ actuator.



For more information on Profibus consult the website at <http://www.Profibus.com>. Profibus is supported by leading PLC manufacturers such as Siemens and Mitsubishi.

## Enhanced Profibus Device Type Manager

In response to customers' requirements, Rotork is releasing a new Profibus Device Type Manager (DTM), for the enhancement of commissioning and asset management across a wide range of actuators in the Rotork range, including IQ, CVA, ROMpak and Skilmatic EH.

The Rotork Profibus DTM works with Field Device Tool (FDT) Technology to provide customers with a standard interface, independent of the communication protocol and the software environment of either the device or host system.

End users have a single point to access and manage data from multiple

networks using different protocols and containing equipment from multiple vendors.

Rotork is a member of the FDT Group and is committed to continually improving and developing the capabilities of this technology to provide customers with the latest capabilities. This is demonstrated by the release of an updated DTM with significantly improved features.

Rotork has invested in interoperability testing with manufacturers including Honeywell, Endress+Hauser, Ifak, M&M Software, the Phoenix Contact Group and Yokogawa to ensure optimum operation in a wide variety of applications.

In addition to configuration, parameterisation and graphing for all supported actuator types, the enhanced DTM detects when it is connected to the latest generation of IQPro Profibus actuators. It then automatically displays the extended actuator configuration data and allows for the downloading of logged data and actuator configuration parameters.

Future plans include development of Foundation Fieldbus and HART device DTMs to complement the existing Profibus DTM which is now available.

The new DTM can be downloaded from the Rotork website, in the Profibus literature section:

<http://www.rotork.com/en/product/index/profibusliterature>

### DTM Explained

A Device Type Manager (DTM) is a piece of software supplied by an equipment manufacturer designed to be used within another piece of software called a Field Device Tool (FDT) Container. Many DTMs can be loaded into customers' FDT Container programmes and provide a single point of access to a variety of setup, parameterisation, monitoring, and asset management information.

The ability to load multiple DTMs into an FDT Container allows support for not only different device types supplied by different manufacturers, but also a variety of different network types.

A graphical interface that follows the FDT Group Style Guide results in a powerful easy to use solution for the customer. Rotork has responded to existing and expected future

customer demand by implementing a DTM solution. This complements other technologies such as EDDL to give customers greater choice.

The Rotork DTM automatically adjusts its behaviour and available data depending on the type of actuator selected, version of Profibus software installed in the connected actuator and if online or offline modes are selected.



# Screenshots

This is an example FDT Container showing a simple Profibus network on the left hand side containing 3 Profibus Rotork Actuators.

This container is available free from M&M Software here:

[http://www.mm-software.com/matrix\\_engine/content.php?page\\_id=417&language=1](http://www.mm-software.com/matrix_engine/content.php?page_id=417&language=1)

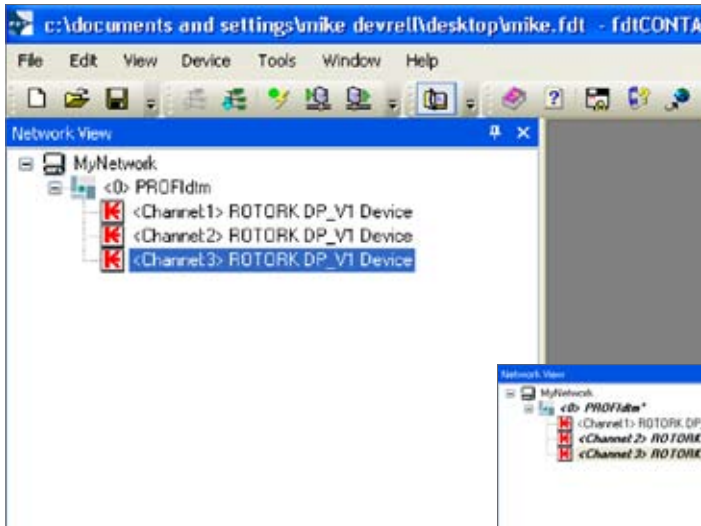

FDT container showing network topology with Rotork actuators added.

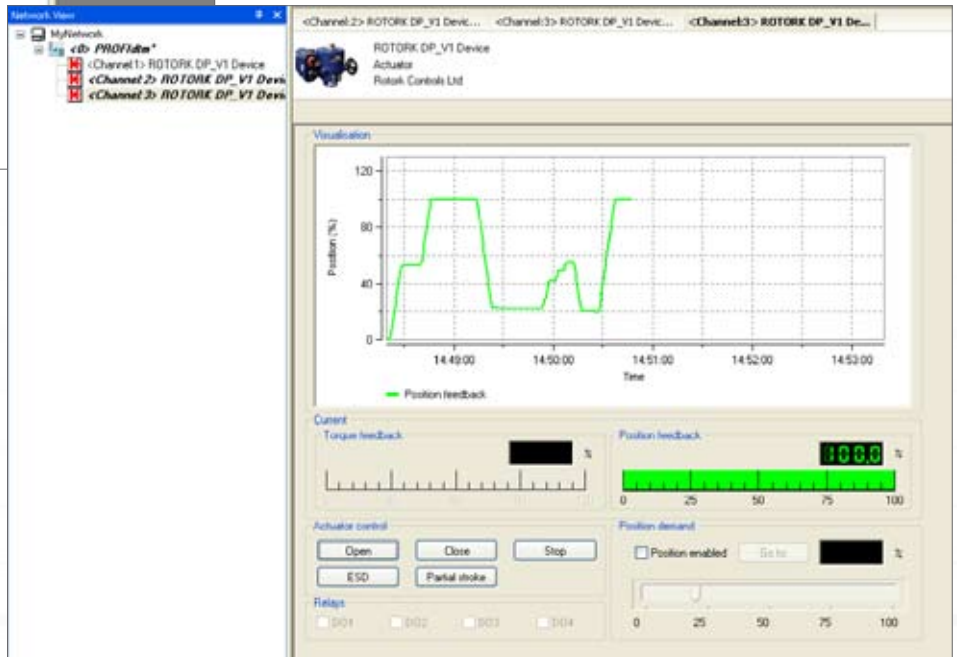

Close up of Actuator Control pages.



Settings screen.

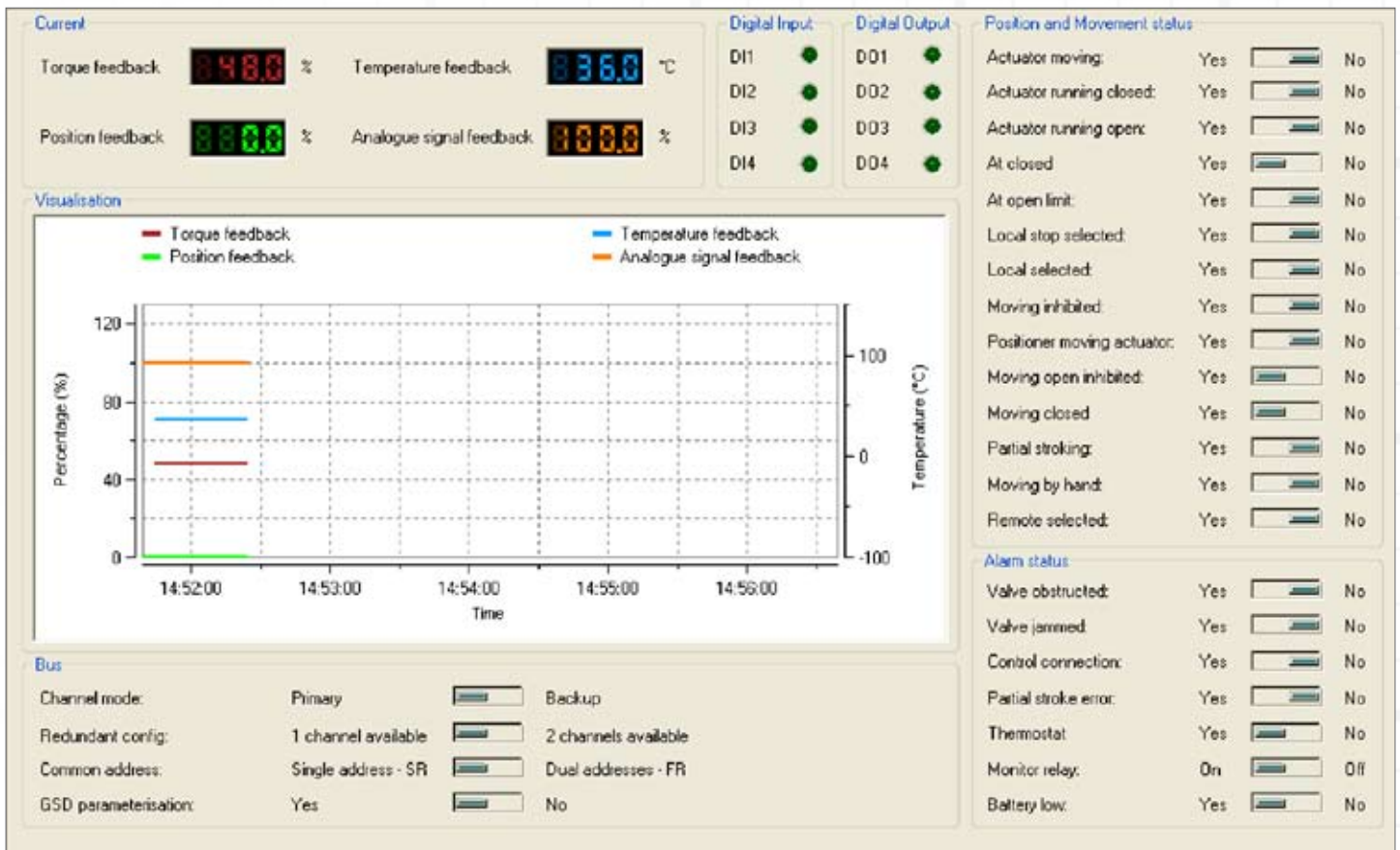

## COMPANY NEWS

## New office increases local support for all Rotork products in the Middle East

**Rotork has opened a second office in the UAE to deliver additional support and service to meet the ever increasing demand for Rotork's entire product range in the Middle East region.**

The new office will provide dedicated local support for fluid power products, complementing the comprehensive local support already provided for electric actuators by the team led by Ashley Watkins at the Rotork Middle East Regional Office. Ashley is based in the UAE at the premises of Universal Technical Llc, who are Rotork's well established agent for electric and fluid power products, providing local contract support, engineering expertise and workshop facilities.

Working in conjunction with the existing office and agent, the new office will be the focus for the further

development of Fluid Systems' capabilities in the area, providing increased sales support, a local centre for quotations and contracts and a faster, more responsive and comprehensive range of after sales services.

The new facility is situated in the Jebel Ali Free Zone in Dubai, an ideal central location for travelling in the UAE and just 30 minutes away from a major international airport. Three qualified staff members – two area sales managers and a regional service manager – are currently based at the office, where staff levels are expected



Pictured in the new office are (left to right): Cristian Corelli and Sunil D'Sa with Vittorio Stefani.

to grow as business continues to expand throughout the region.

Rotork Fluid Systems' growth in recent times has created one of the largest fluid power actuator manufacturers in the world with the most extensive product range available from a single company. The Middle East is an important destination for much of this product and the new office will ensure

that all customers in the area receive the high level of proactive service that is expected from Rotork.

**The full address of the Dubai office is:**

Rotork Fluid Systems M.E.  
Jafza View LOB 181207  
Jebel Ali Free Zone  
PO Box 262903  
Dubai UAE  
Tel/Fax: +971 (0) 48857215



## New Service Centre gives further support to a buoyant Indian market

**Responding to a steady increase in the demand for Rotork products in India, a dedicated new Service Centre has been established at the Rotork Chennai factory.**

The new office and workshop facilities will give customers a focussed and highly efficient service, providing actuators, spares and overhaul services, and offering a quick response for a full range of maintenance and repair activities.

The 1200 sq. ft. workshop is equipped with five work benches, served by a 500kg capacity crane to facilitate the handling of the largest actuators. A dedicated stores area has been introduced to maintain the availability of material stocks for quick

overhauls and the assembly of spares orders, whilst a new test rig has been installed to ensure that refurbished actuators are despatched in a fully tested and certified condition.

In addition to maintenance and repair, the new workshop will also facilitate extended scope activities such as the provision of actuated valve packages and associated equipment.

Three full time service engineers and two service technicians are available to meet customers' requirements, for either workshop or on-site applications. Experienced staff members are also on hand to give advice on every aspect of the services offered.

For more information on ROTALK articles and features contact ROTORK Bath: +44 (0)1225 733200 email: [uksalesadmin@rotork.com](mailto:uksalesadmin@rotork.com)

**rotork**<sup>®</sup>

**UK**  
Rotork plc  
tel +44 (0)1225 733200  
fax +44 (0)1225 333467  
email [mail@rotork.com](mailto:mail@rotork.com)

**USA**  
Rotork Controls Inc  
tel +1 (585) 247 2304  
fax +1 (585) 247 2308  
email [info@rotork.com](mailto:info@rotork.com)

Rotalk is published and printed by Rotork Controls Ltd. in the UK.

[www.rotork.com](http://www.rotork.com)