

Electric Actuators and Control Systems

# rotork® Controls

Established Leaders in Valve Actuation

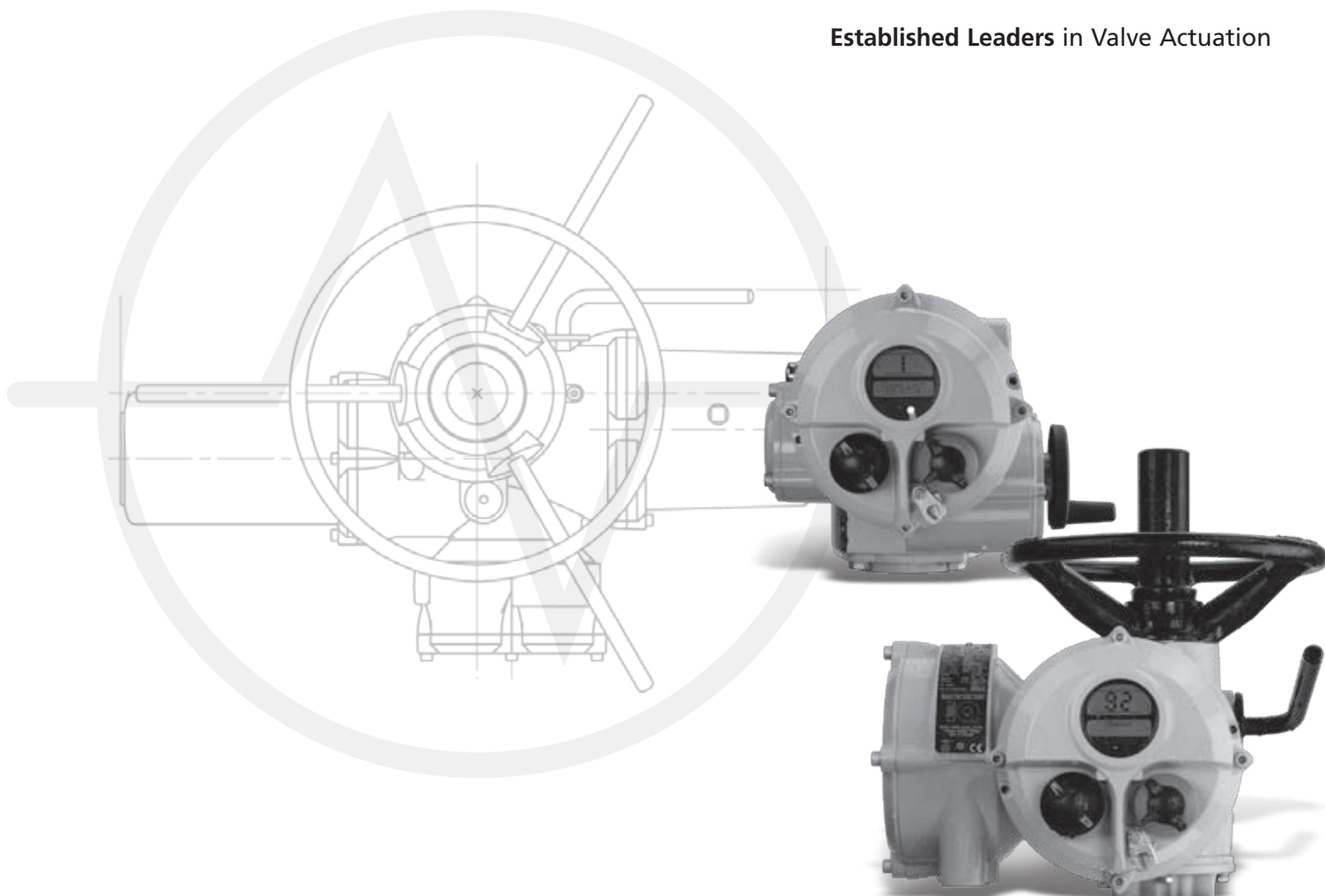

## ***IQ Pro*** Range

**Control and Monitoring Facilities**

**IQ and IQT Multi-turn and Quarter-turn  
Electric Valve Actuator**

Publication E120E Issue 12/09

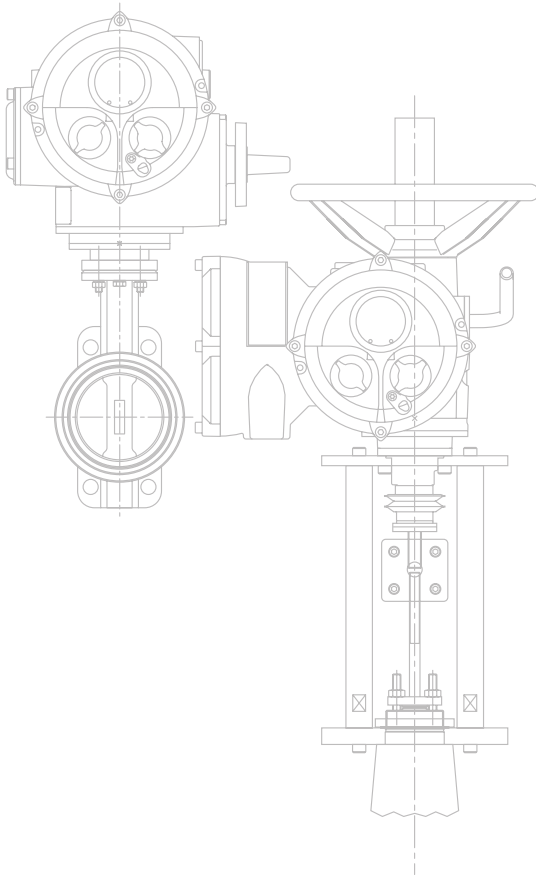

Section	Page
IQ – In control	3
Actuator electrical specification	4
Control specification	7
Indication, Monitoring and Data Logging	9
Fieldbus Systems	11
Actuator circuit diagrams	12
ESD and interlock control circuits	15
Remote control circuits	16
Analogue control circuits	18

Rotork's proven *IQ Pro* range of actuators is now further enhanced with the addition of alternative actuator power supplies and a dedicated part-turn actuator - *IQT Pro*.

*IQ Pro* and *IQT Pro* range actuators are self-contained, non-intrusive units for local and remote electrical operation of valves.

#### **IQ Pro Multi-turn actuator range:**

- IQ - 3-phase power supplies.
- IQS - single-phase power supplies.
- IQD - DC power supplies.

#### **IQT Pro Quarter-turn actuator range:**

- Intelligent, non-intrusive quarter-turn actuator incorporating all the benefits of standard IQ control and indication features.
- Suitable for 3-phase, single-phase and 24 VDC power supplies.
- Operating speed can be varied.

Refer to publication E110 for IQ and IQT range performance and specification.

The *IQ Pro* and *IQT Pro* ranges comprise an electric motor, reduction gearing, reversing starter with local controls, position and torque limitation with electronic logic controls and monitoring facilities, all housed in a double-sealed watertight enclosure to IP68 (7 metres - 72 hours), NEMA 4 and 6.

All settings including torque, limit and indication contacts are made using the non-intrusive, hand held, infra-red IQ Setting Tool *Pro*, included with each order.

The following specification covers standard and optional features. Options selected must be specified with order.



**IQ Pro** - the first valve actuator you can commission and interrogate without removing electrical covers. With the infra-red IQ Setting Tool *Pro* and PC based IQ-Insight, commissioning and analysis of IQ *Pro* actuators is simple, fast and convenient.

### **IQ Insight –Actuator configuration and analysis tool for PC.**

IQ-Insight PC software allows all IQ set-up configuration and datalogger information to be reviewed, analysed and reconfigured. The visually interactive application is a stand-alone program running under Microsoft Windows 2000™ or XP™ operating systems. Intuitive and clear menus make analysing data from an IQ simple and fast.

### **Data Logging & Configuration**

Every IQ includes an on board data logger. The data logger captures and stores valve, actuator and control signal operation and status data and can be viewed using IQ Insight. Log data is time and date stamped and can be analysed by playing back on an event by event basis.

In addition, actuator set-up configuration can be viewed and stored using IQ Insight for complete actuator asset management or future upload/replication of other units.

### **Features:**

- Actuator configuration
- Valve torque profile - open/closed instantaneous and average torque against valve position
- Virtual nameplate
- Number of operations
- Control option card configuration
- Valve and actuator position starts log
- Operation signal log
- Actuator control status log
- Operational statistics.

### **New Setting Tool Pro**

Configuration and datalogger files can be extracted from the actuator located in the field using the Setting Tool *Pro* for transfer to office based PC. The Tool is watertight and intrinsically safe so can be used in wet and/or hazardous areas. Data upload/download is non-intrusive via IrDA™. The tool can store up to 10 configuration files or 4 datalogger files (which includes unit configuration file).

If required, a PC running IQ-Insight with a USB IrDA™ dongle can be directly connected to an actuator to allow set-up, adjustment and analysis. Alternatively, a PDA running IQ Pocket-Insight, may be used.

*For more information refer to publication E117 available at [www.rotork.com](http://www.rotork.com)*

### **Setting Tool Specification**

Waterproof IP67, Certified EEx ia IIC T4 (intrinsically safe).

Power Supply 2 x AA 1.5 V Batteries (supplied & fitted).

Operating range 0.75 m from actuator display window.

Setting Tool(s) are dispatched with each order. Setting Tools are suitable for use with any IQ or IQT range actuator.

*For more information on Setting Tool and commissioning, refer to publications E170-3 - IQ range & E175-3 - IQT range.*



## Actuator electrical specification

### Power supply

The electrical supply type and nominal operating voltage must be specified at time of order. Actuator performance is guaranteed with a voltage tolerance +/-10% and frequency tolerance +/-5%. Actuators are capable of starting and running up to speed with a maximum 15% volt drop.

### Non-standard tolerances

Where voltage and/or frequency variations may be experienced outside those quoted below, or where operation under large volt drop conditions may be required, please apply to Rotork.

### IQ Pro range power supplies

#### IQ – 3-phase power supplies

IQ actuators are available for operation with the following standard 3-phase, three wire, nominal power supplies:

##### 50 Hz

220, 240, 380, 400, 415, 440, 460, 500, 525, 550, 660 and 690 Volts

##### 60 Hz

208, 220, 230, 240, 380, 440, 460, 480, 575 and 600 Volts

Refer to publication E110 for IQ performance summary and E130 for IQ - 3-phase power supply rating data.

#### IQS – single-phase power supplies

IQS actuators are available for standard nominal voltages:

##### 50 Hz

110, 220, 240

##### 60 Hz

110, 220, 230

Refer to publication E110 for IQS performance summary and E130 for IQ single-phase power supply rating data.

#### IQD – DC power supplies

IQD actuators are available for standard nominal voltages:

24 V\*, 48 V\*, 110 VDC

Refer to publication E110 for IQD performance summary and E130 for IQD DC power supply rating data.

\* Limited by actuator size - refer to E110 IQD performance summary.

### IQT Pro range power supplies

IQT range of actuators is available for the following power supplies without change in performance\*\*.

Refer to publication E110 for IQT performance summary and E135 IQT range power supply rating data.

#### IQT – 3-phase power supplies

Actuators are suitable for operation with the following standard 3-phase, three wire, nominal power supplies:

##### 50 Hz

200, 220, 240, 380, 400, 415, 440, 480, 500, 550, 660 and 690 Volts

##### 60 Hz

200, 208, 220, 230, 240, 380, 400, 440, 460, 480, 575, 590, 600, 660 and 690 Volts

#### IQT – single-phase / 2-phase power supplies

##### 50 Hz

110, 115, 120, 220, 230, 240 Volts

##### 60 Hz

100, 110, 115, 120, 208, 220, 230, 240 Volts

#### IQT - DC power supplies

24 VDC\*

24 VDC 'Solar'\*

\* IQT - 24 VDC: speed may vary with load.

### Non-standard voltages

Actuators can be supplied to operate on power supply voltages other than those quoted above.

Please apply to Rotork.

### Uninterruptible power supplies

Standard actuators can be operated on UPS systems providing the above specified tolerances are not exceeded and waveforms, harmonics, spikes etc. adhere to recognised supply standards such as EN50160.

For more information please refer to publication E130.

### Conduit entries

IQ and IQT range actuators have a separately sealed terminal compartment incorporating a segregated terminal block and cable / conduit entries.

It is the responsibility of the installer to ensure the appropriate cable / conduit adaptors, glands and blanking plugs are fitted in order to maintain hazardous area certification and ingress protection rating. Certified adaptors and blanking plugs are available as optional extras.

### IQ Pro range

Three threaded conduit entries are provided, tapped: 1 x 1 1/2" and 2 x 1" ASA NPT. Unless otherwise specified, actuator will be dispatched with adaptors: 1 x M40 and 2 x M25 metric to BS3643, "Ex" certified or as an alternative, 1 x PG29 and 2 x PG16.

### Options

If specified with order, a fourth conduit entry can be provided, tapped 1" ASA NPT with adaptor to M25 or as an alternative, PG16.

### IQT Pro range

Two threaded conduit entries are provided tapped M25. When requested, 2 x 3/4" ASA NPT adaptors will be provided.

### Options

Adaptors are available to convert standard conduit entries to the following: 1", 1 1/4", 1 1/2" - ASA NPT or metric M20. Two additional conduit entries can be provided when specified, sizes as above.

### Terminals

The IQ and IQT range actuators incorporate a terminal block containing segregated metric screw terminal inserts. M5 pan head terminal screws are provided for power terminals and M4 pan head terminal screws for control and indication. The terminal box cover carries a terminal identification code card. Each actuator is supplied with instruction book and wiring diagram.

## Wiring

Jig built harnesses of individually numbered stranded conductors, tropical grade PVC insulated, connect internal components to the sealed terminal block. All internal control connections to the printed circuit boards are via plugs and sockets. Wiring of contacts to outgoing terminals is size Ø1.02 mm or cross sectional area 0.82 mm<sup>2</sup> (18 AWG).

## Motor

### IQ – 3-phase

Class F insulated, squirrel cage motor of special high torque low inertia design. 15 minute rated with cyclic duration factor of 25% at 33% of actuator output rated torque giving a temperature rise not exceeding that permitted for Class B insulation at standard nominal voltage. Actuator rated up to 60 starts per hour at a rate not exceeding 600 starts per hour. Burnout protection by embedded thermostats, with facility for bypassing under emergency shutdown control. Motors conform to IEC34, NEMA MG1 and BS4999.

### IQS – single-phase

Single-phase capacitor start/run squirrel cage induction motor. Class F insulated, special high torque, low inertia design. Rating, protection and compliance as per 3-phase specification above.

### IQD – DC

Class F insulated, permanent magnet DC motor. Rating, protection and compliance as per 3-phase specification above.

### IQT

The IQT utilises a 24 V permanent magnet DC motor 15 minute rated with cyclic duration factor of 25% at 75% of actuator rated torque. Actuator rated up to 60 starts per hour at a rate not exceeding 600 starts per hour. Thermostat protection coupled to transformer package allowing complete power supply and motor protection.

*Note: On AC power supplies the 24 VDC supply for the motor is produced internally by a transformer rectifier assembly.*

## Motor options

### IQ Range

Class H, 30 minute rated motors are available for certain applications. Please apply to Rotork.

### Modulating

For applications requiring more than 60 starts/hour please refer to IQM publication E110.

## Electrical Control Module – ECM Control PCB

Incorporating a single integrated circuit, hard-wired logic control for the actuator together with infra-red (IrDA™) interface. On board data logger records operational data, valve torque/position profiles and statistical information, all time and date stamped.

## Torque Switch and Position Control

Position and torque are adjustable as follows:

- **IQ Range**  
Position setting range: 2.5 to 100,000 turns, with a minimum angular resolution of 15° at the output.
- **IQT Range**  
Position setting range: 80 - 100° (mechanical stops), resolution 0.1° of full 90° travel.
- **Torque switch setting**  
40% to 100%

For IQ range, output torque is obtained via measurement of wormshaft displacement under load and is independent of voltage, frequency and temperature fluctuations. In the case of IQT range, torque is derived from motor current by the motor controller and is independent of speed and supply voltage.

“Torque off” during unseating or during starting/reversing in mid travel against high inertia loads can be inhibited. A “jammed valve” protection circuit de-energises the motor if no movement occurs after receipt of a signal to open or close.

The IQ and IQT ranges incorporate a battery to update and maintain both local LCD and remote “S” contact indication of actuator/valve status when power to the actuator is isolated. Should manual operation of the valve take place during a power supply interruption, both local and remote indication is updated. Unlike other actuator makes, a secondary low voltage power supply is not required to update local and remote valve position indication.

Expected battery life is 5 years. The status of the battery is indicated by the actuator display. Remote indication of battery status is available with actuator “S” contact indication.

All actuator configured settings are stored in non-volatile EEPROM (Electrically Erasable, Programmable Read Only Memory). EEPROM does not require any power supply to maintain the stored configured settings and is therefore completely independent of the battery.





## Actuator electrical specification

### Protection features

The IQ and IQT range includes the following protection features:

#### Torque protection

If the torque produced in operating the valve when closing or opening reaches that set for the active torque switch, the motor will be de-energised. The torque switches are independently configurable in the range 40 - 100% of rated torque. In addition the open torque switch can be configured to "boost", allowing the motor to generate torque in excess of rated torque to enable operation of "sticky" valves. Local and remote indication of torque trip is provided.

#### Motor over temperature protection

For IQ range two thermostats are located within the motor stator. IQT thermostats are located within the motor supply toroidal power transformer for AC supply and on the motor polarity protection bridge rectifier for 24 VDC supply. This arrangement provides comprehensive protection for both the power supply circuitry and the motor. In both cases the thermostats will trip and de-energise the motor if the temperature exceeds its rating. Local and remote indication of thermostat tripped is available. The thermostat can be overridden during an ESD operation.

#### Automatic phase rotation correction

The actuator will always run in the correct direction regardless of the sequence of power supply connection.

#### Lost phase protection

If any one or more power supply phases are lost, the motor cannot be energised. Local and remote indication of lost phase is available.

#### Jammed valve protection

Should the actuator stall when attempting to unseat a valve stuck in its seat, the motor will be de-energised within 7 seconds, preventing damage. Local and remote indication of jammed valve is available.



#### Instantaneous reversal protection

The motor control logic introduces a delay in switching the motor as a response to instant reversal of control signals, preventing contact damage to the contactors. Overtorque transients due to switching high inertia loads are prevented from causing a torque trip by the motor control logic.

#### ASTD Automatic Self Test and Diagnosis

On power up the actuator automatically tests its vital operational circuits and memory devices to ensure correct operation. In the unlikely event of a device problem the IQ diagnoses the cause and will automatically present this information in the form of an error message. Electrical operation can be inhibited to prevent possible damage to the actuator and valve. The problem can then be accurately investigated and corrected by maintenance personnel. Local and remote indication of ASTD Fault is available.

#### Power module

The power module incorporates a mechanically and electronically interlocked reversing contactor starter.\* For IQ and IQT ranges on AC supplies the control supply transformer, fed from two phases of the incoming power supply, provides internal control circuit supplies and an isolated, nominal 24 VDC supply rated at 5 W for actuator fed remote control circuits. The transformer is of a "split bobbin" double insulated design and incorporates short circuit and overload protection. For IQD and IQT-24 VDC the control circuit and customer supplies are provided via DC/DC converters. The Rotork Syncrophase™ circuit provides automatic phase rotation correction and lost phase protection where applicable.

#### Option

Actuator fed remote control supply: Nominal 120 VAC supply, rated at 15 VA. (not available with IQD and IQT 24 VDC power supply).

\* IQS Single-phase, IQT and IQM modulating units utilise a solid state motor starter.

## Local Control

Non-intrusive selectors are provided on the actuator's electrical control cover, one for Local/Stop/Remote selection, pad-lockable in each position, and the other for Open/Close control. Local control may be configured for maintained or inching operation.

Controls may be rotated to suit actuator orientation.

Local control may be selected to operate using the supplied IQ Setting Tool. The Setting Tool incorporates dedicated Open, Stop and Close buttons and will operate over a nominal distance of 0.75 metres from the display window.

## Vandal Resistant Local Control Option

Control selectors removed, indication window with or without removable cover, control of Local, Stop and Remote selection and local Open and Close control is via the IQ Setting Tool.

## Remote Control

There are six control inputs for remote control:

- Open, Close, stop/maintain
- Emergency shut down (ESD)
- Open interlock and Close interlock

Control can be connected for maintained or push to run, "inching" control. Refer to pages 15-18 for remote control circuit schematics.

Remote control inputs are opto-isolated interfaces with a surge immunity of 2 kV. Standard control is positive switching (negative switching is available if specified).

The standard IQ actuator can be controlled using remote control signals defined as follows:

Customer fed control circuit supply:  
Within the ranges, 20-60 V AC/DC or 60-120 VAC.

Actuator fed control circuit supply:  
24 VDC. (120 VAC available if specified).

The current drawn for each control input:

5 mA at 24 VDC, 12 mA at 120 VAC  
Minimum "ON" voltage: 20 V,  
Maximum "OFF": 3 V.  
Minimum signal duration: 300 ms.  
Maximum remote control cable capacitance: 2 µF core to core.

## IQD & IQTD - DC actuator remote control

Remote control is available within the ranges 20-120 VAC, 20-60 VDC, only. Note: for IQD at 110 VDC power supply, the maximum remote control input voltage is 60 VDC.

For applications where the actuator is powered from a power supply of limited capacity such as solar power charged, direct current UPS system, power conservation is of prime importance. The IQD/IQTD include a "solar" feature\* to minimise power consumption when not operating, reducing the current drawn by the actuator control to 10 mA (maximum). Applying a remote "Open", "Close" or "ESD" control signal or a discreet "wake up" signal causes the actuator to power up its control circuits and after a delay of up to 10 seconds, respond to the remote control signal. Between 3 and 6 seconds after the control signal is removed, the actuator returns to the low current "solar" state.

As part of this routine, in order to save power, the actuator fed 24 VDC remote control supply is disabled when in solar mode. i.e. actuator 24 VDC fed remote control supply is unavailable for applying a signal to power up the actuator control when operation is required and therefore a discreet externally fed "wake up" signal or externally powered control signals must be used.

Three modes of control are available:

- Standard - sleep function disabled, 24 VDC remote control supply available at all times.
- "Solar" sleep function enabled, 24 VDC remote control supply **disabled** when asleep.
- "Solar" sleep function enabled, 24 VDC remote control supply **enabled** when asleep.

Unless otherwise specified, the actuator will be dispatched configured in the "solar" mode of control. Remote control signals must therefore be a minimum of 10 second duration. The 2-wire remote control form is not available (refer to page 17). For Fieldbus system control please apply to Rotork.

In local control and when "awake", the actuator will draw approximately 100 mA (with 24 VDC Power Supply) from the supply in the quiescent state.

## Remote control option

For customer fed remote control in the range 60-125 VDC an alternative control circuit is available (note: IQD is limited to 20-60 VDC and 20-120 VAC only).

## Emergency Shut Down – ESD

An active ESD signal will override any local or remote control signal. The ESD input operates from a separate common to that used for Open, Close, and Stop remote control signals. Refer to page 15 for ESD circuit options.

The following ESD options can be configured:

- **ESD Signal**  
Active high (contact making - NO)  
Active low (contact breaking - NC)
- **ESD Action**  
Close, Open, Stayput
- **ESD Override**  
Motor thermostat\*\*, local stop, active interlocks, interrupter timer option

Unless specified with order, the actuator will be dispatched set for the following:

Active high signal (contact making - NO), Close on ESD. ESD will not override motor thermostat, local stop, active interlock or interrupter timer.

\* Factory configured.

\*\* Bypassing the motor thermostat will invalidate hazardous area certification.

## Control specification

### Interlocks

External hardwired interlocks for opening, closing or both directions can be configured to inhibit local and remote operation until the external contacts are made. Interlock circuits may be added with any of the remote control circuits. The interlock inputs operate from a separate common allowing for isolation between the safety system and operation control system. Refer to page 15 for standard interlock circuit options.

### Conditional control

For applications where a high level of control integrity is required the IQ can be configured for "conditional control". In this mode, operation is conditional on two discrete signals being applied. Looking at an example of a "close valve" command, by applying a signal to the "remote close input" and "close interlock input" simultaneously the actuator will operate and close the valve. If only one signal is applied or a signal is lost, the actuator will fail-safe by staying put or stopping. When conditional remote control is configured the interlock inputs are not required for local operation.

### SIL Applications

IQ Pro range including "SIL" Safety Function Control Module option is TÜV certified for use in SIL 2 safety applications using a 1 out of 1 actuated valve configuration (1oo1). Safety functions are "Stayput" and "ESD". The SIL option can be included with any new IQ or IQT range actuator or be retrofitted to existing actuators supplied since 2000. Where SIL 3 is required, IQ Pro-SIL may be used in a 1oo2 actuated valve configuration.

*For detailed information refer to publication E1121 available at [www.rotork.com](http://www.rotork.com)*

### Remote control options

#### Analogue Control - Folomatic Option

The IQ Folomatic proportional controller enables the actuator to automatically position a valve in proportion to an analogue current, voltage or potentiometric signal. A signal derived

from the actuator non-contacting position sensor is electronically compared with a signal proportional to the input signal. The difference between them (error) triggers the open or close contactor via logic circuits to drive the actuator in the direction that will cancel the error. Valve position is therefore automatically adjusted in proportion to analogue signal. Unnecessary frequent operation can be prevented by the adjustable Folomatic deadband and the Motion Inhibit Timer features.

Positioning can take place over the whole valve stroke or if required, a set portion of stroke. By incorporating a remote manual/auto selector, proportional control can be overridden allowing standard remote control to take place when manual intervention is required.

### Application

Reversing motor-driven electromechanical actuators are suitable for proportional control in automatic control loops in which the system rate of change is relatively slow, and high accuracy continuous modulation is not essential; level controls in water and sewage treatment plants are typical applications. Motor operated regulating valves and sluice gates are driven through nut and screw or wormgear mechanisms which must be self-locking and are therefore mechanically inefficient. Frequent operation will cause rapid wear of these components. The control systems should therefore be designed to avoid this. Stem nut life will be maximised if the valvemaking uses a stem thread with a lead of one third of the diameter.

Standard IQ actuators are suitable for regulating applications requiring up to 60 starts/hour providing the average torque required by the valve in mid stroke does not exceed 33% of the rated torque of the selected actuator. Where modulating applications require increased rates of starts per hour, the IQM and IQML actuator ranges can be operated up to a rate of 1200 starts/hour and include configurable DC injection motor braking to reduce overrun.

*For more information please refer to publication E410.*

### Accuracy

The Folomatic positioner accuracy is 1%. Because of the backlash in nuts, screws and gearing of industrial valves, overall accuracy may not be quantified prior to the valve and actuator being put into service. To optimise positional accuracy, actuator output speeds should be kept as low as practicable. Rotork do not recommend output speeds in excess of 29 rpm. The maximum signal change required to cause response in the same direction (ie. not through deadband) is 1%. Output resolution will be a function of actuator speed, number of output turns between set limits and valve stem thread or gearing backlash.

### Folomatic Configuration

The Folomatic can be configured to suit signals within the following ranges:

#### Analogue signals/input impedance:

0-5 mA / 1 k $\Omega$	0-5 V / 1 M $\Omega$
0-10 mA / 500 $\Omega$	0-10 V / 78 k $\Omega$
0-20 mA / 250 $\Omega$	0-20 V / 52 k $\Omega$
4-20 mA / 250 $\Omega$	

#### Position corresponding to low input signal:

Closed limit, or percentage open, or Open limit.

#### Position corresponding to high input signal:

Closed limit, or percentage open, or Open limit.

#### Deadband:

0-9.9% of travel between Open and Closed limit positions.

#### Motion inhibit time:

2-99 sec between actuator movements.

#### Action on loss of input signal:

Stay-put, move to high or low signal position. Available for minimum set "low" signal of 0.5 mA. Response on loss of signal will occur if signal falls below 50% of set "low" signal.

### Connections

For analogue control connections, and analogue control connections with remote manual override, refer to page 18.



## Reduced speed, hydraulic shock and surge protection - Interrupter Timer option

Where the operating time of the valve must be reduced to prevent hydraulic shock or “water hammer”, or to prevent surges, the Interrupter Timer option can be included. Pulsed operation with independently adjustable “on” and “off” time periods in the range 1-99 seconds can be selected to operate over any portion of the closing or opening valve stroke. On/Off time period range may be extended when configuration is carried out with the IQ-Insight tool. The interrupter timer is active for both local and remote control.

## Local Position and Local Monitoring Indication

A back-lit liquid crystal display gives digital indication from fully Open to fully Closed in 1% increments. Three LED's coloured red, green and yellow for indication of Open, Close and intermediate positions respectively are also provided. The display includes a 2 x 18 character dot matrix display for status and error message reporting.

With the IQ Setting Tool, actuator torque can also be displayed allowing the valve torque against position to be monitored in real time.

Help screen diagnosis is available for monitoring valve, actuator and control system status. The local display can be rotated to suit actuator orientation. LED colours can be reversed. Please specify at time of order.

## Remote position and monitoring indication

Four latching, volt free, single pole contacts, S1, S2, S3 and S4 are provided, each one independently configurable using the IQ Setting Tool to signal one of the following:

- **Valve Position**  
Fully Open, fully Closed (exact) or any intermediate positions (0-99% open)

- **Status**  
Valve opening, closing, moving (continuous or pulsing signal), local stop selected, local selected, remote selected, open or close interlock active, ESD active
- **Valve Alarms**  
Motor tripped on torque in mid travel, motor tripped on torque going open, going closed, valve jammed, actuator being operated by handwheel.
- **Actuator Alarms**  
Lost phase, customer 24 VDC (120 VAC) supply lost, battery low, internal failure detected, thermostat tripped.

Each contact can be configured either 'normally open' or 'normally closed'.

## Contact rating

Contacts are nominally rated at 5 mA to 5 A, 120 VAC, 30 VDC. However as long as the switched circuit power remains within the specified limit of 60 W (inductive) or 150 W (resistive), then the following maximum ratings can be achieved: -

Maximum switching Voltage – 120 VAC or DC

Maximum switching Current – 5 A

For example, to operate a 48 VDC external relay (inductive), the maximum permissible current that can be switched through S1 – S8 contacts is calculated by the equation  $P/V=I$  i.e.  $60 \text{ (W)} / 48\text{V} = 1.25 \text{ A}$

Unless otherwise specified S contacts will be configured as follows:

- S1 – contact makes at fully Closed
- S2 – contact makes at fully Open
- S3 – contact breaks at fully Closed
- S4 – contact breaks at fully Open

## Monitor Relay

An independent relay with a volt-free changeover contact for monitoring actuator electrical availability is provided. Contacts are nominally rated at 5 mA to 8 A, 120 VAC, 30 VDC. However as long as the switching power remains within the specified limit of 170 W (inductive) or 240 W (resistive), then the following maximum ratings can be achieved: -

Maximum switching Voltage – 120 VAC or DC

Maximum switching Current – 8 A

The relay will de-energise under any one, or combination, of the following conditions:

- Loss of one or more of the power supply phases
- Loss of control circuit supply
- Local control selected
- Local stop selected
- Motor thermostat tripped

## Data Logger

The on board data logger allows infra-red, IrDA™ download of historical actuator / valve performance to PC or PDA. For hazardous areas the intrinsically safe Rotork IQ Setting Tool Pro is available. Rotork IQ-Insight PC software allows data logger information of operational events and statistics all time and date stamped plus valve torque/position profiles, to be analysed.

Refer to page 3.



## Indication options

### Indication Options

#### Remote Valve Position Analogue Indication - CPT

The Current Position Transmitter (CPT) provides a non-contacting internally fed 4-20 mA analogue signal proportional to valve position. Selectable for minimum signal corresponding to fully Closed or fully Open position with automatic zero and span setting. Available at terminals 22(+ve) and 23(-ve), the maximum external impedance that may be connected to the signal is 500 Ohms at nominal supply voltage. Repeatability is within  $\pm 1\%$  and linearity  $\pm 1\%$  of total valve travel.

#### Auxiliary Powered CPT (not available with IQD)

The auxiliary powered CPT maintains analogue position indication when the mains power is switched off. An auxiliary 24 VDC supply is permanently connected to the actuator, which is automatically switched in to provide power to the CPT on mains failure. On re-instating the mains, the auxiliary supply is automatically switched out.

Note: on mains failure, a surge of up to 1 Amp is required to switch in the auxiliary supply. The "power off" quiescent load is nominally 180 mA, but will depend on the options fitted. It is recommended that the 24 V auxiliary supply is permanently applied to the actuator to limit switch surge current.

#### Remote Valve Torque Analogue Indication - CTT

The Current Torque Transmitter (CTT) provides a non-contacting internally fed 4-20 mA analogue signal proportional to actuator output torque (0-120% of rated torque). When stationary the CTT output will continue to indicate the current torque.

#### Extra indication contacts (not available with IQD & IQS)

The extra indication contacts option provides four additional changeover contacts, S5, S6, S7 and S8. Each contact is latching, volt free and rated at 5 mA to 5 A, 120 VAC, 30 VDC. The extra indication contact functions are independently configurable in the same way as the standard contacts using the IQ Setting Tool. The extra indication contact functions are shown below:

- **Valve Position**  
fully open, fully closed or intermediate positions (0-99% open).
- **Status**  
Valve opening, closing, moving (continuous or pulsing signal), local stop selected, local selected, remote selected, open or close interlock active, ESD active.
- **Valve Alarms**  
Motor tripped on torque in mid travel, motor tripped on torque going open, going closed, valve jammed, actuator being operated by hand wheel.
- **Actuator alarms**  
Lost phase, customer 24 VDC (120 VAC) supply lost, battery low, internal failure detected, thermostat tripped.

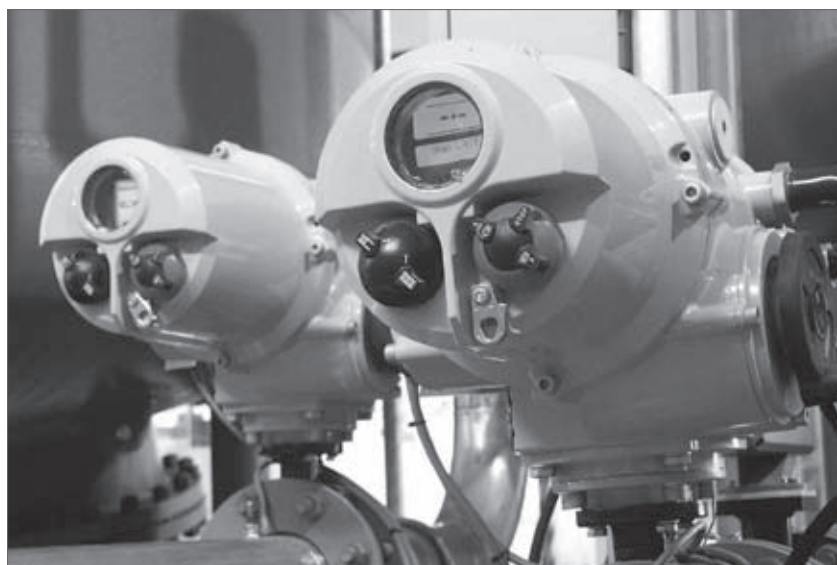

## Pakscan

Rotork's own 2-wire system for control and data transmission to and from the actuators.

An internally mounted Pakscan field unit connects the actuator to the field network. By arranging the field cable in a loop the system automatically provides a fault tolerant redundant path for the data signals. The communication distance may be up to 20 km in length without the need for repeaters, up to 240 actuators may be connected to the loop and a master station supervises the system. Communication from the master station to the host uses Modbus protocol over RS232 and RS485. System settings for the actuator are programmable over the infra-red data link.

*Please refer to publication S000.*

## Modbus

Single or dual Modbus Modules may be included in the IQ actuator to provide remote serial communication to the control functions and for status feedback data. The field network uses an RS485 data highway, either 2 or 4 wire, and can be duplicated where redundancy is required. The communication is half duplex and the protocol used is Modbus RTU with data rates up to 38 K baud. The actuator variables necessary to set up the system are programmable over the infra-red data link.

*Please refer to publication E121.*

## Profibus

Profibus connectivity is possible by fitting the Profibus DP interface module within the IQ actuator. This allows the IQ to be integrated into a standard Profibus network. Full compatibility with the fieldbus standard EN 50170 is provided and the module carries Profibus certification for inter-operability. The network allows full control of the actuator and feedback of status data to the host. The Rotork Profibus module has two communication ports to facilitate redundant fieldbus wiring where reliability is paramount, data rates up to 1.5 M baud are supported.

*Please refer to publication S113.*

## Foundation Fieldbus

IQ actuators may be connected to a Foundation Fieldbus network (H1) by the inclusion of a Rotork FF-01 module. The device complies with fieldbus standard IEC 61158-2, using a 2-wire electrical connection to the highway and has been certified for inter-operability. The Foundation highway exchanges data and control between devices and full actuator functionality is available. Each actuator has full link scheduler capability complete with function blocks for analogue and digital inputs/outputs in addition to the standard transducer block. Foundation fieldbus networks are capable of operating without a host system as a supervisor, allowing the field devices to communicate directly between themselves.

*Please refer to publication S114.*

## Additional Inputs and Outputs

When used in conjunction with a fieldbus network the actuator can also collect additional feedback information from other devices in the field such as level switches or proximity detectors. It is also possible with some systems to provide additional output control functions to operate remote equipment, pump starters etc. In order to provide these features the actuator requires the Fieldbus Remote I/O option which includes 4 digital inputs for feedback data and 4 dry contact relay outputs for control.

The availability of these functions is indicated in the table below:

### Fieldbus Remote I/O option fitted

Fieldbus Option	
4 digital inputs	4 digital outputs
<b>Pakscan</b>	
Yes	No
<b>Single Modbus Module</b>	
Yes	Yes
<b>Dual Modbus Module</b>	
Yes	No
<b>Profibus</b>	
Yes	Yes
<b>Foundation Fieldbus</b>	
Yes	Yes

# Actuator circuit diagram - basic

**IQ Actuator Basic Circuit Diagram 3000-000, drawn in mid-travel, power off**

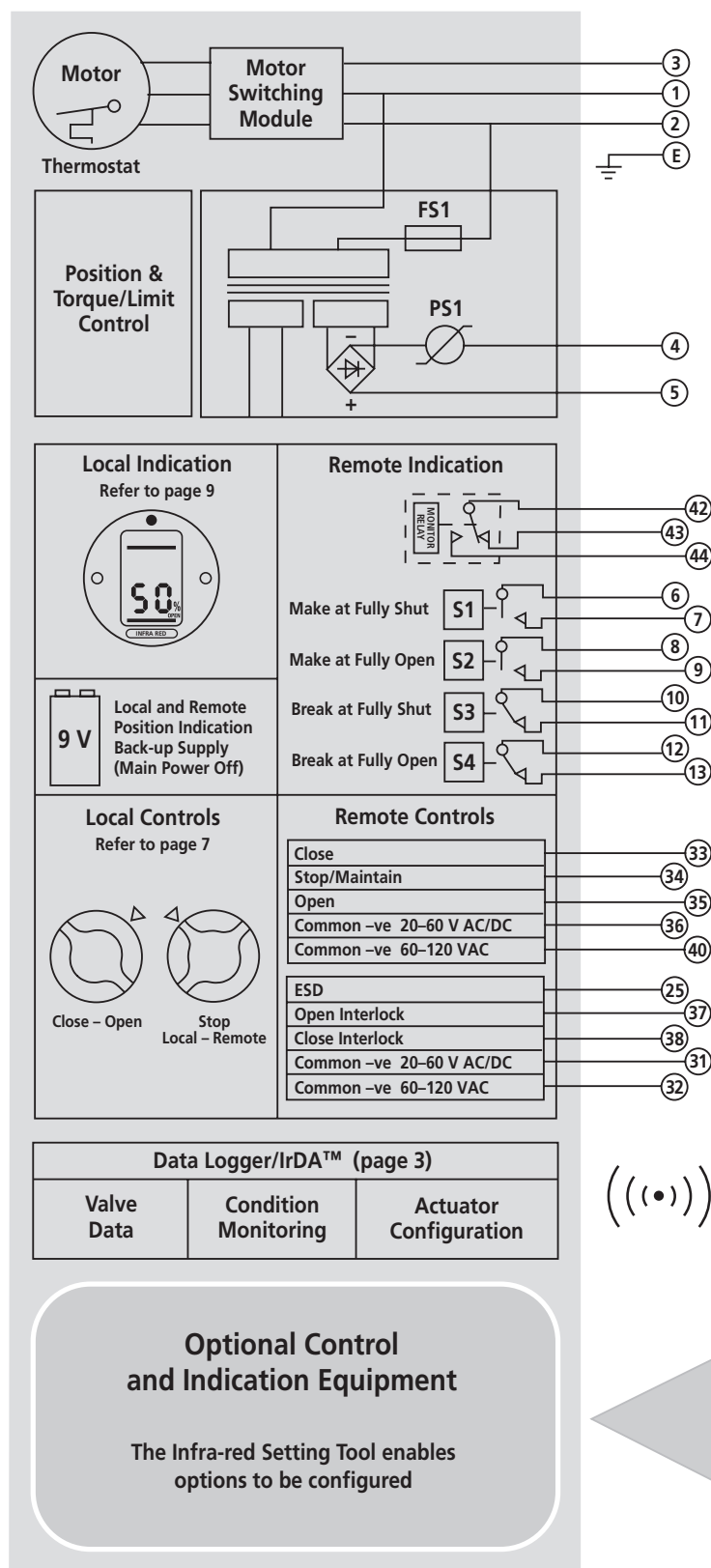

**Actuator Power Supply**  
Refer to page 4  
(power supply connections will vary with actuator type. Connections shown are for IQ 3-phase only).

**Isolated, nominal 24V DC, 5W Power Supply** (120 VAC 15 VA option)  
Available for actuator fed remote control.  
Refer to page 6.

**Monitor Relay** Monitors actuator availability (shown de-energised – unavailable). Refer to page 9.

**Indication Contacts**  
Shown in default configuration. Configuration can be changed using the IQ Setting Tool to indicate any valve position, status and alarm settings. Refer to page 9.

**Remote Control Inputs**  
Refer to pages 15 and 16 for control circuit types.

**Infra-red/IrDA™ interface.**

For applicable Circuit Diagram refer to the Matrix on page 14.

# Actuator circuit diagram – options



## Optional control and indication equipment

Close Limit

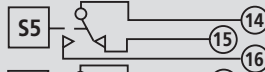

Open Limit



Torque Trip Mid-Travel



Remote Selected



### Extra Indication Contacts

Shown in default configuration. Configuration can be changed using the IQ Setting Tool to indicate various valve and actuator position, status and alarm settings. Contacts are shown in not true state. Refer to page 10

### Analogue Position Control Folomatic

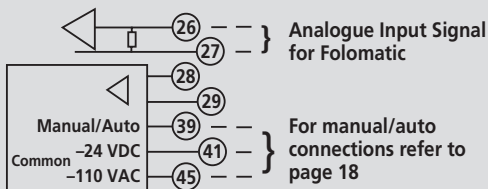

### Valve Position – CPT

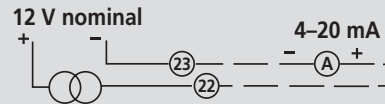

### Valve Torque – CTT

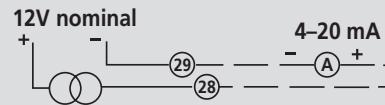

### Pakscan 2-Wire Loop

Care should be taken to ensure that circuits connected to terminals 4 or 5 are not connected directly or indirectly to ground.

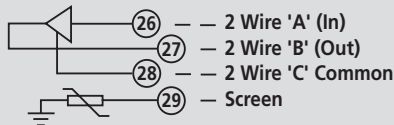

### Profibus RS485 Highway

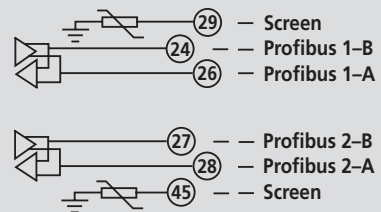

### Modbus 2 Wire/4 Wire RS485 Highway

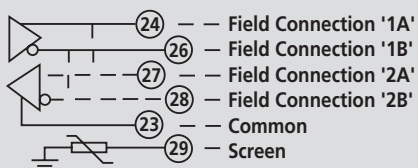

### Foundation Fieldbus IEC61158-2 Highway

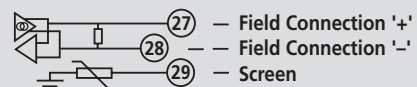





# Emergency Shut Down ESD and Interlock control circuits



## ESD and Interlock control circuits may be added to any of the Remote or Analogue circuits shown on pages 16-18.

Emergency Shut Down ESD signal will override any existing local or remote signal. The actuator can be configured to open, close or stayput as a response to an ESD signal. ESD signals must be derived from a latching contact. The actuator can be configured to respond to an ESD from a “making” or “breaking” contact.

If required, ESD operation can be configured to override the motor thermostat, local stop, active interlocks or Interrupter Timer option. Overriding the motor thermostat during ESD will invalidate hazardous area certification.

Unless specified with order the actuator will be dispatched set for the following: Active high signal (contact making), Close on ESD. ESD will not override motor thermostat, local stop, active interlock or interrupter timer.

Changes in ESD configuration are made using the supplied IQ Setting Tool *Pro*.

### Interlock circuit control

The default setting is for the interlock function turned OFF. If interlock facilities are required the IQ Setting Tool can be used to configure the interlocks ON.

Interlocks are active in both local and remote control. If only one interlock is required, the other must be linked out as shown.

Traditional hardwired interlock systems between actuators such as “Main and Bypass” in steam plant can be easily arranged using the IQ “S” contacts to derive the permissive control signal.

### Key

- ④ 24 VDC -ve
- ③① ESD/IL Common 20-60 V AC/DC
- ③② ESD/IL Common 60-120 VAC
- ③⑦ Open Interlock
- ③⑧ Close Interlock
- ②⑤ ESD/Thermostat bypass
- ⑤ 24 VDC +ve

### ESD Control Circuits

Form 1F



▲ ESD - Internally fed ▲

Form 2F

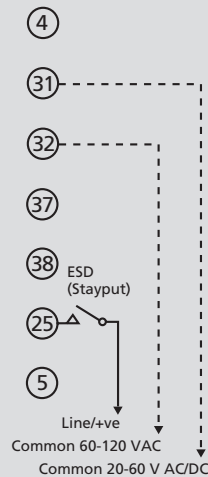

▲ ESD - Externally fed ▲

### Interlock Control Circuits

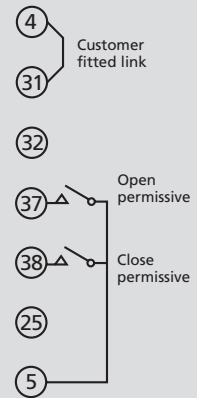

▲ Open/Close Interlock active – Internally fed ▲

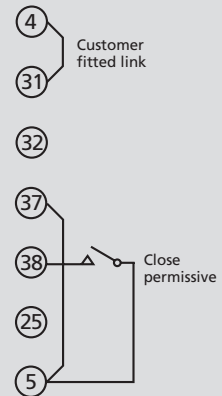

▲ Close Interlock active – Internally fed ▲

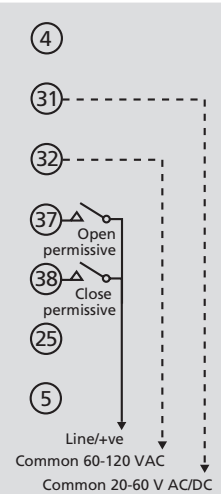

▲ Open/Close Interlock active – Externally fed ▲

## Remote control circuits

### Remote control system wiring schematics for standard IQ/IQT are shown opposite.

Standard actuators are dispatched without terminal links.

A commissioning bag located in the terminal compartment includes terminal screws, spare cover o-rings, actuator circuit diagram, and the Installation and Maintenance instruction, publication E170-3/E175-3. The actuator including the IQ Setting Tool *Pro* will be indicated with a yellow label on the terminal compartment cover.

Remote control inputs are optoisolated interfaces with a surge immunity of 2 kV. Standard control is positive switching (negative switching is available if specified).

The standard IQ actuator can be controlled using remote control signals defined as follows:

Customer fed control circuit supply:  
Within the ranges, 20-60 V AC/DC or 60-120 VAC.

Actuator fed control circuit supply:  
24 VDC, 5 W rated. (120 VAC, 15 VA available if specified).

The current drawn for each control input:

5 mA at 24 VDC, 12 mA at 120 VAC.

Minimum "ON" voltage: 20 V.

Maximum "OFF": 3 V.

Minimum signal duration: 300 ms.

Maximum remote control cable capacitance: 2  $\mu$ F core to core.

**Internal supply -ve (zero) ▶**

**Common for remote controls on 20 V to 60 VDC or AC ▶**

**Common for remote controls on 60 V to 120 VAC ▶**

**Close ▶**

**Stop/maintain ▶**

**Open ▶**

**Internal 24 VDC supply +ve (or internal 120 VAC) ▶**

**Internal supply -ve (zero) ▶**

**Common for remote controls on 20 V to 60 VDC or AC ▶**

**Common for remote controls on 60 V to 120 VAC ▶**

**Close ▶**

**Stop/maintain ▶**

**Open ▶**

**Internal 24 VDC supply +ve (or internal 120 VAC) ▶**

Open/Close push-to-run control.

Form 1A

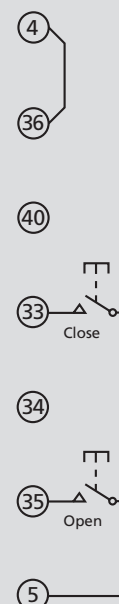

Form 2A

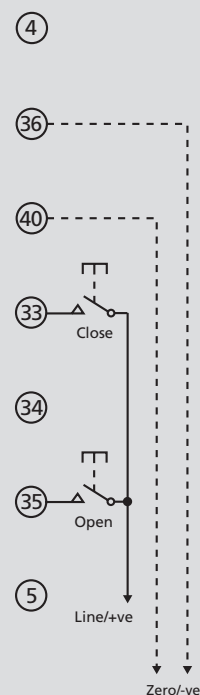

**Open/Close maintained control with mid-travel reverse.**  
Form 1B

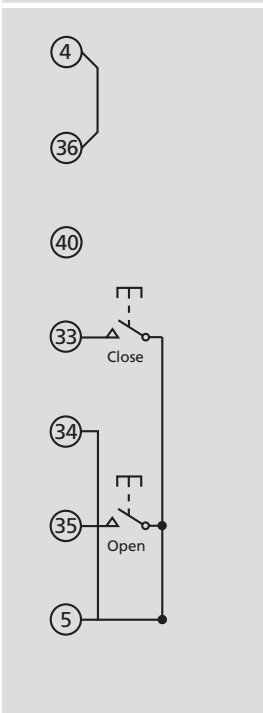

**Open/Stop/Close maintained control.**  
Form 1C

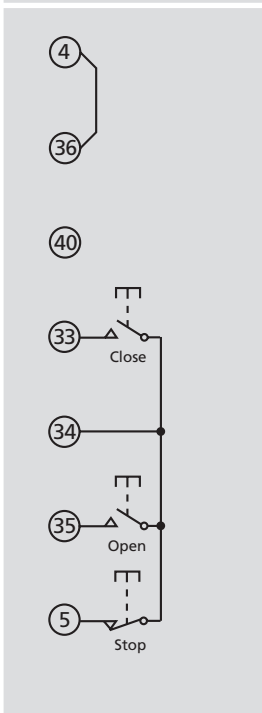

**Two-wire control; energize to Open, de-energize to Close.**  
(Configure for Open priority).  
Customer to link 5 - 33.  
Form 1D

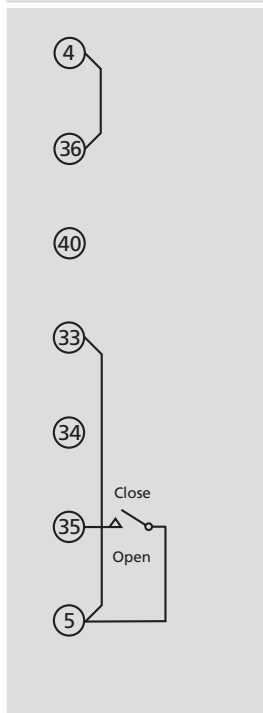

**Two-wire control; energize to Close, de-energize to Open.**  
(Configure for Close priority).  
Customer to link 5 - 33.  
Form 1E

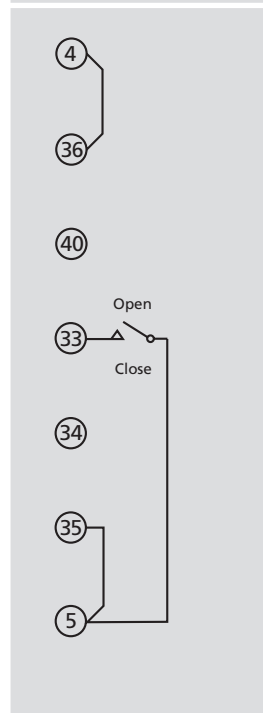

Form 2B

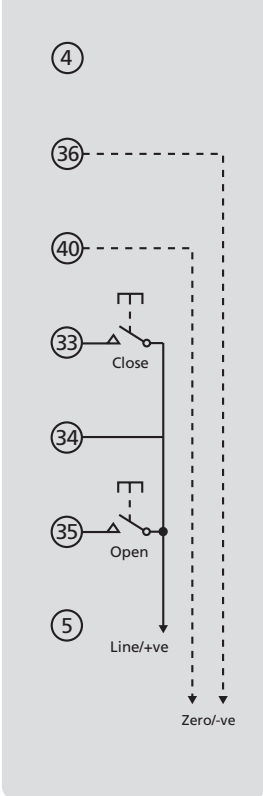

Form 2C

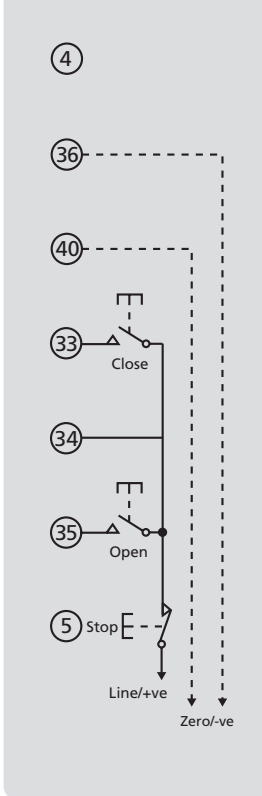

Form 2D

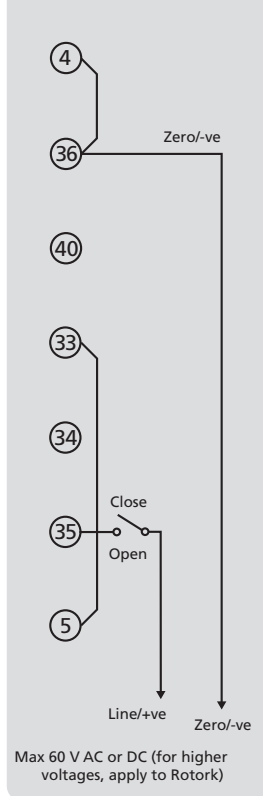

Form 2E

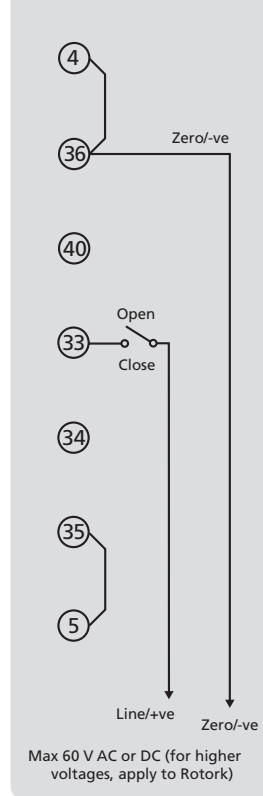

# Analogue control circuits

## Analogue Folomatic control only

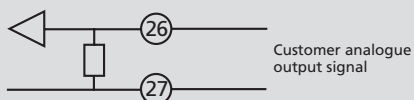

## Analogue Folomatic control with internally fed remote manual override

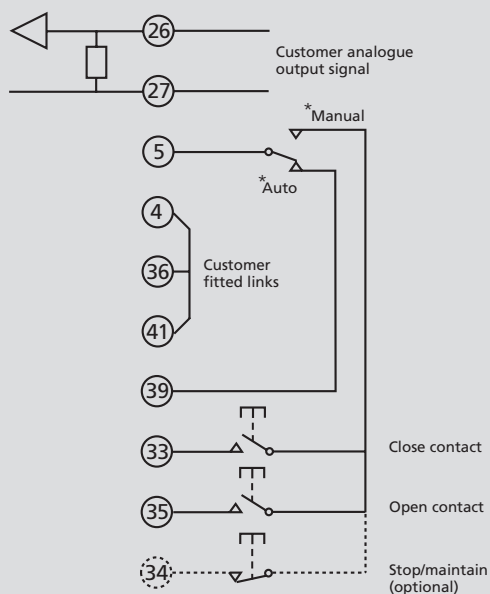

### Key

- ②⑥ Folomatic +ve
- ②⑦ Folomatic -ve
- ⑤ 24 VDC +ve
- ④ 24 VDC -ve
- ③⑥ Control Common 20-60 V AC/DC
- ④① Control Common 60-120 VAC
- ④① Folomatic Common 20-60 V AC/DC
- ④⑤ Folomatic Common 60-120 VAC
- ③⑨ Folomatic manual/auto
- ③③ Remote manual Close
- ③⑤ Remote manual Open
- ③④ Remote manual Stop/Maintain

## Analogue Folomatic control with externally fed remote manual override

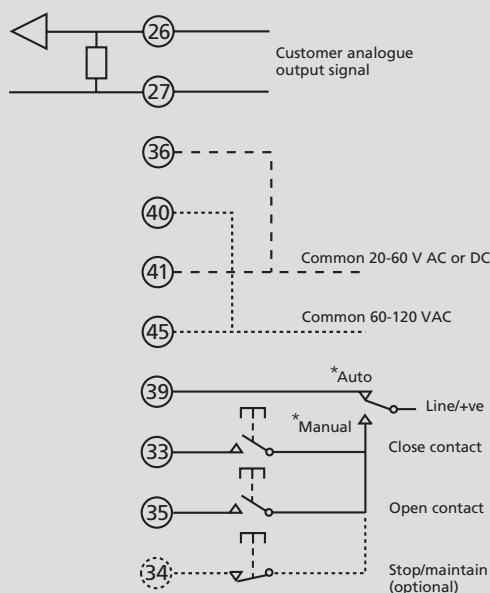

\* If Manual/Auto override is required this must be enabled in the configuration menus



## Partial stroke function

**The actuator can be set to perform a partial stroke test upon a valid signal being applied to the Open Interlock. This allows for systems to be tested periodically without interruption, to verify valve movement.**

The partial stroke function is enabled by selecting partial stroke in the interlock menu. Further partial stroke functions such as Partial Stroke – Limit, Position and Timeout can then be adjusted to suit the application. As the function uses the Open Interlock, the interlock function cannot be used with partial stroking.

For extra diagnostic coverage, there are two new relay configurations that can be used – Partial Stroke Active and Partial Stroke Error, which can be found in the relay setting menu, refer to publications E170-3 and E175-3 for further details.

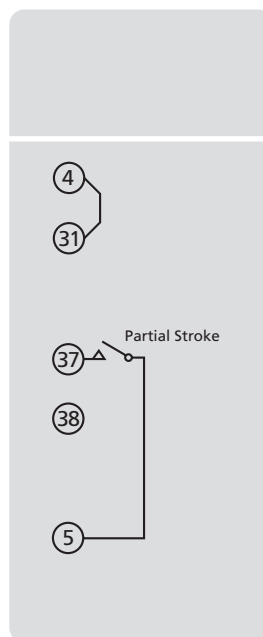

### Key

- ④ 24V DC -ve
- ③① ESD/IL Common 20-60 V AC/DC
- ③⑦ Open Interlock
- ③⑧ Close Interlock
- ⑤ 24 VDC +ve



A full listing of our worldwide sales and service network is available on our website.

*UK*  
Rotork plc  
*tel* +44 (0)1225 733200  
*fax* +44 (0)1225 333467  
*email* mail@rotork.co.uk

*USA*  
Rotork Controls Inc.  
*tel* +1 (585) 247 2304  
*fax* +1 (585) 247 2308  
*email* info@rotork.com

### **Controls**

Electric Actuators and Control Systems

### **Fluid Systems**

Fluid Power Actuators and Control Systems

### **Gears**

Gearboxes and Gear Operators

### **Site Services**

Projects, Services and Retrofit

[www.rotork.com](http://www.rotork.com)

As part of a process of on-going product development, Rotork reserves the right to amend and change specifications without prior notice. Published data may be subject to change. For the very latest version release, visit our website at [www.rotork.com](http://www.rotork.com)

The name Rotork is a registered trademark. Rotork recognises all registered trademarks. Published and produced in the UK by Rotork Controls Limited. POWTG1209