

rotork[®]
Instruments

Pneumatic Cylinders

MP/MR Series

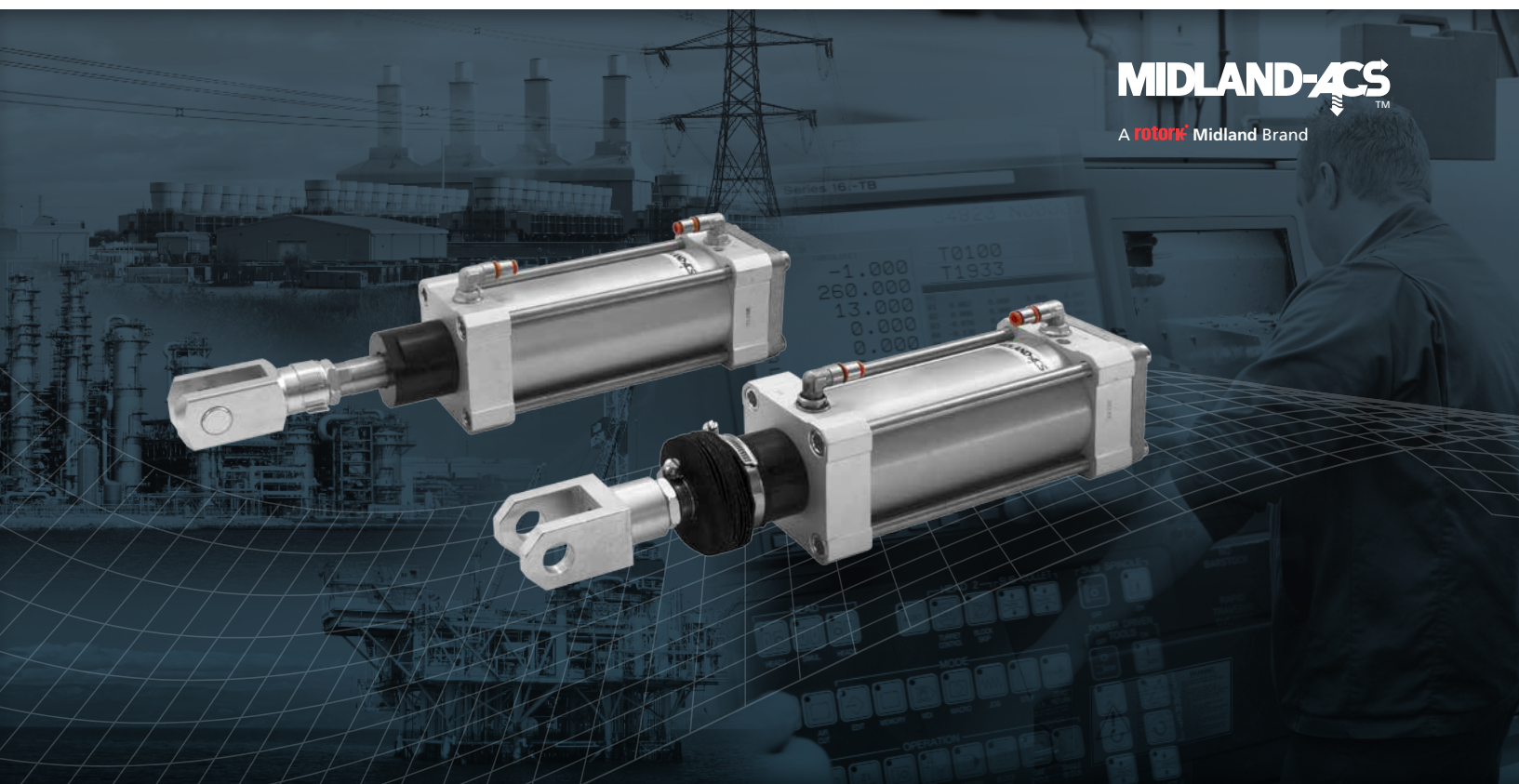

MIDLAND-ACS[™]

A rotork Midland Brand

rotork[®]
MIDLAND

Keeping the World Flowing

Contents

Section	Page	Section	Page
General		Mountings	
General Description and Benefits	3	Front Flange (MF1) and Rear Flange (MF2)	15
Functional Symbols	3	Feet (MS1)	15
Model Code	5	Rear Clevis (MP2)	15
Preferred Models – Basic Cylinders	6	Rear Eye (MP4)	16
Cylinder Sizing	7	Rear Hinge Mount (MP2 + MP4 + Pivot Pin)	16
Installation Dimensions – Basic Profile and Round Barrel Cylinders	8	Rear 90° Hinge (MP2 + 90° Bracket + Pivot Pin)	16
		Intermediate Trunnion (MT4)	17
Cylinder Options		Accessories	
Double Acting through Rod Cylinders	9	Fork End with lockable Pivot Pin	18
Double Acting Rear Connection Cylinders	10	Fork End with Pivot Pin	18
Double Acting Front Connection Cylinders	10	Rod Spherical Bearing	18
Double Acting High Temperature Cylinders	11	Pivot Pin	19
Double Acting Gaitered Cylinders	12	Piston Rod Locknut	19
Double Acting Positioner Controlled Cylinders	13	Magnetic Sensors	
		Reed Switch	20



Rotork is the global market leader in valve automation and flow control. Our products and services are helping organisations around the world to improve efficiency, assure safety and protect the environment.

We strive always for technical excellence, innovation and the highest quality standards in everything we do. As a result, our people and products remain at the forefront of flow control technology.

Uncompromising reliability is a feature of our entire product range, from our flagship electric actuator range through to our pneumatic, hydraulic and electro-hydraulic actuators, as well as instruments, gearboxes and valve accessories.

Rotork is committed to providing first class support to each client throughout the whole life of their plant, from initial site surveys to installation, maintenance, audits and repair. From our network of national and international offices, our engineers work around the clock to maintain our position of trust.

Rotork. Keeping the world flowing.

VDMA/ISO Power Cylinders, Double Acting – 32, 40, 50, 63, 80, 100, 125 mm bore

General Description and Benefits

Rotork Midland produce a range of double acting, fully adjustable cushioned metric cylinders to VDMA 24562 and BS ISO 6431 standards.

Profile barrels (MP range) or with conventional round barrels (MR range).

- Simple reliable design
- Meets International and European standards
- Clean lines
- Magnetic piston option
- Customers required stroke supplied as standard
- Adjustable air cushioning
- Lube free
- Full range of mounting accessories
- Customised designs available

Functional Symbols

*Double acting
Double cushioned*



*Double acting through rod
Double cushioned*



*Double acting rear connection twin cylinders
Double cushioned*



*Double acting front connection twin cylinders
Double cushioned*

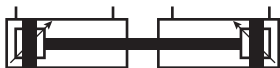

*Double acting braking cylinder
Double cushioned*



*Double acting positioner controlled cylinder
Double cushioned*

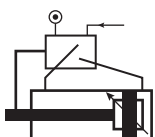

Operating Fluids

Compressed Air

Filtered and lubricated or non lubricated up to 12 bar (174 psi).

ISO VG32 or ISO VG37 mineral oil is recommended for use in lubricated systems.

Technical Data

Operating Pressure

Standard 0.5 to 10 bar (7.25 to 145 psi)

Maximum 0.5 to 12 bar (7.25 to 174 psi)

Ambient Operating Temperature Range

-10 °C to +85 °C (14 °F to 185 °F)

Ports

Screwthread 1/8" – 3/4" BSP

Cushioning

Fully adjustable air cushioning at both ends.

Cushioning Length

32 mm bore cylinders – 19 mm

40 mm bore cylinders – 23 mm

50 mm bore cylinders – 21 mm

63 mm bore cylinders – 23 mm

80 mm bore cylinders – 24 mm

100 mm bore cylinders – 29 mm

125 mm bore cylinders – 36 mm

VDMA/ISO Power Cylinders, Double Acting – 32, 40, 50, 63, 80, 100, 125 mm bore

Materials of Construction

Barrel

Profile tube (MP range). Hard anodised aluminium alloy.

Round tube (MR range). Hard anodised aluminium alloy.

End Covers

Hard anodised aluminium alloy.

Piston Rod

Stainless steel AISI 303.

Piston

Aluminium.

Tie Rods

Stainless steel AISI 303.

Seals

Polyurethane 92° shore hardness.

Options – Nitrile and Fluoroelastomer.

Mountings

Aluminium alloy, epoxy coated.

Steel, zinc plated or galvanised.

Service Kits

Basic Cylinders

32 mm bore – M0321PSK

40 mm bore – M0401PSK

50 mm bore – M0501PSK

63 mm bore – M0631PSK

80 mm bore – M0801PSK

100 mm bore – M1001PSK

125 mm bore – M1251PSK

Cylinders with Nitrile Seals

Change code 'P' in position 6 to code 'N' – i.e. M0321NSK

Cylinders with Fluoroelastomer Seals

Change code 'P' in position 6 to code 'V' – i.e. M0321VSK

Through Rod Cylinders

Change code '1' in position 5 to code '4' – i.e. M0324PSK

Rear Connection Twin Cylinders

Change code '1' in position 5 to code '5' – i.e. M0325PSK

Front Connection Twin Cylinders

Change code '1' in position 5 to code '6' – i.e. M0326PSK

Positioner Controlled Cylinders

Details on application.

VDMA/ISO Power Cylinders, Double Acting – 32, 40, 50, 63, 80, 100, 125 mm bore

Model Code	***	-	***	-	*	-	*	-	*	-	***	x	****
	1	-	2	-	3	-	4	-	5	-	6	x	7
Model													
Magnetic Piston													
MPE	= Profile barrel (32 – 200 mm bore)												
MRE	= Round barrel (32 – 200 mm bore)												
Non Magnetic Piston													
MP	= Profile barrel (32 – 100 mm bore)												
MR	= Round barrel (32 – 100 mm bore)												
Bore¹													
032	= 32 mm		080	= 80 mm									
040	= 40 mm		100	= 100 mm									
050	= 50 mm		125	= 125 mm									
063	= 63 mm												
Function													
1	= Double acting												
4	= Double acting with rod through both ends												
5	= Double acting rear connection twin cylinders												
6	= Double acting front connection twin cylinders												
8	= Double acting fitted with electropneumatic positioner unit 4 – 20 mA (40 – 125 mm bore)												
9	= Double acting fitted with pneumatic positioner unit 0.2 – 1bar / 3 – 15 psi (40 – 125 mm bore)												
Type of Cylinder													
D	= Double cushioned air cylinder												
Seals													
N	= NBR 70 (32 – 100 mm bore)												
P	= Polyurethane (preferred)												
V	= Fluoroelastomer												
Special Features													
MT4	= Intermediate trunnion ²						GE	= Gaitered (401 – 500 mm stroke)					
CE	= Cam extends with increase in signal pressure ³						GF	= Gaitered (501 – 600 mm stroke)					
CR	= Cam retracts with increase in signal pressure ³						GG	= Gaitered (601 – 700 mm stroke)					
GA	= Gaitered (0 – 100 mm stroke)						GH	= Gaitered (701 – 800 mm stroke)					
GB	= Gaitered (101 – 200 mm stroke)						GJ	= Gaitered (801 – 900 mm stroke)					
GC	= Gaitered (201 – 300 mm stroke)						GK	= Gaitered (901 – 1000 mm stroke) ⁴					
GD	= Gaitered (301 – 400 mm stroke)												
Stroke													
Standard strokes:- Any stroke up to 3000mm													
For twin cylinders state both strokes e.g. x0100x0160													

Notes:

1. 125 mm bore available in magnetic piston version only.
2. Code MT4 applies to MR range of cylinders only.
3. Codes CE and CR apply to positioner only – codes 8 and 9 in position 3.
4. Strokes over 1000 mm for gaitered cylinders available to special order – contact Customer Services for further details.

VDMA/ISO Power Cylinders, Double Acting – 32, 40, 50, 63, 80, 100, 125 mm bore

Preferred Models – Basic Cylinders

Profile Barrel, Magnetic Piston

Bore	Model Code	Mass kg
32 mm	MPE0321DP x Stroke	0.55 + 0.057/25 mm
40 mm	MPE0401DP x Stroke	0.83 + 0.080/25 mm
50 mm	MPE0501DP x Stroke	1.34 + 0.116/25 mm
63 mm	MPE0631DP x Stroke	2.00 + 0.127/25 mm
80 mm	MPE0801DP x Stroke	3.25 + 0.186/25 mm
100 mm	MPE1001DP x Stroke	5.00 + 0.218/25 mm
125 mm	MPE1251DP x Stroke	6.40 + 0.335/25 mm

Round Barrel, Magnetic Piston

Bore	Model Code	Mass kg
32 mm	MRE0321DP x Stroke	0.55 + 0.057/25 mm
40 mm	MRE0401DP x Stroke	0.83 + 0.080/25 mm
50 mm	MRE0501DP x Stroke	1.34 + 0.116/25 mm
63 mm	MRE0631DP x Stroke	2.00 + 0.127/25 mm
80 mm	MRE0801DP x Stroke	3.25 + 0.186/25 mm
100 mm	MRE1001DP x Stroke	5.00 + 0.218/25 mm
125 mm	MRE1251DP x Stroke	6.65 + 0.343/25 mm

Profile Barrel, Non Magnetic Piston

Bore	Model Code	Mass kg
32 mm	MP0321DP x Stroke	0.55 + 0.057/25 mm
40 mm	MP0401DP x Stroke	0.83 + 0.080/25 mm
50 mm	MP0501DP x Stroke	1.34 + 0.116/25 mm
63 mm	MP0631DP x Stroke	2.00 + 0.127/25 mm
80 mm	MP0801DP x Stroke	3.25 + 0.186/25 mm
100 mm	MP1001DP x Stroke	5.00 + 0.218/25 mm

Round Barrel, Non Magnetic Piston

Bore	Model Code	Mass kg
32 mm	MR0321DP x Stroke	0.55 + 0.057/25 mm
40 mm	MR0401DP x Stroke	0.83 + 0.080/25 mm
50 mm	MR0501DP x Stroke	1.34 + 0.116/25 mm
63 mm	MR0631DP x Stroke	2.00 + 0.127/25 mm
80 mm	MR0801DP x Stroke	3.25 + 0.186/25 mm
100 mm	MR1001DP x Stroke	5.00 + 0.218/25 mm

Ordering example:

MPE0501DPx0100 = 50 mm bore, 100 mm stroke profile barrel double acting cylinder with polyurethane seals and magnetic piston.

MR0801DPx0250 = 80 mm bore, 250 mm stroke round barrel double acting cylinder with tie rods, polyurethane seals and non magnetic piston.

VDMA/ISO Power Cylinders, Double Acting – 32, 40, 50, 63, 80, 100, 125 mm bore

Cylinder Sizing

Selection of Suitable Bore Size

1. Establish thrust required and available working pressure of air supply.

Determine whether static or dynamic application – for dynamic applications it is recommended that a thrust of 30% in excess of required loading be allowed.

2. Using the thrust tables given below

a) Select the working pressure.

b) Select the thrust required – if exact thrust is not shown use nearest larger unit.

c) Read off cylinder bore size.

Theoretical Thrust

Thrust in Newtons assuming a cylinder efficiency of 85%.

Bore mm	Direction	Air Pressure – Bar									
		1.0	2.0	3.0	4.0	5.0	6.0	7.0	8.0	9.0	10.0
32	EXTEND	68	137	205	273	342	410	478	547	615	683
	RETRACT	59	117	176	235	293	352	411	470	529	587
40	EXTEND	107	213	320	427	534	640	747	854	961	1068
	RETRACT	89	179	269	359	448	538	627	717	807	897
50	EXTEND	167	333	501	667	834	1000	1168	1335	1501	1668
	RETRACT	140	281	420	560	700	841	981	1121	1261	1401
63	EXTEND	265	530	795	1059	1324	1589	1854	2118	2383	2648
	RETRACT	238	476	714	952	1191	1429	1667	1905	2143	2381
80	EXTEND	427	854	1281	1709	2135	2562	2989	3416	3844	4270
	RETRACT	385	771	1156	1541	1927	2312	2697	3083	3468	3853
100	EXTEND	667	1335	2002	2669	3336	4004	4671	5338	6005	6673
	RETRACT	626	1251	1877	2502	3128	3753	4379	5004	5630	6253
125	EXTEND	1042	2084	3126	4168	5211	6253	7295	8337	9379	10421
	RETRACT	974	1948	2922	3896	4871	5845	6819	7793	8767	9741

Useful Cylinder Calculations

Thrust

$$T = P \times A \times E \times 10^3$$

A = Effective piston area (dm²)

C = Air consumption (dm³/sec)

E = Cylinder Efficiency

Air Consumption

$$C = \frac{A \times L \times N \times (P + 1.013)}{101.3}$$

L = Stroke (mm)

N = Single strokes per second

P = Pressure (bar)

Air Flow

$$Q = \frac{A \times L \times (P + 1.013)}{t \times 101.3}$$

Q = Air flow (dm³/sec) free air

T = Thrust (Newtons)

t = Time for single stroke (secs)

Useful Conversions

1N = 0.102 kgf

1N = 0.225 lbf

1kgf = 9.807 N

1lbf = 0.454 kgf

1scfm = 0.472 dm³/sec

1psi = 0.069 bar

60 l/min = 1 dm³/sec

1kg/cm² = 0.981 bar

14.5 psi = 1 bar

1bar = 0.10 Mpa

VDMA/ISO Power Cylinders, Double Acting – 32, 40, 50, 63, 80, 100, 125 mm bore

Installation Dimensions mm

Basic Profile Barrel Cylinders

MP****1D*x****

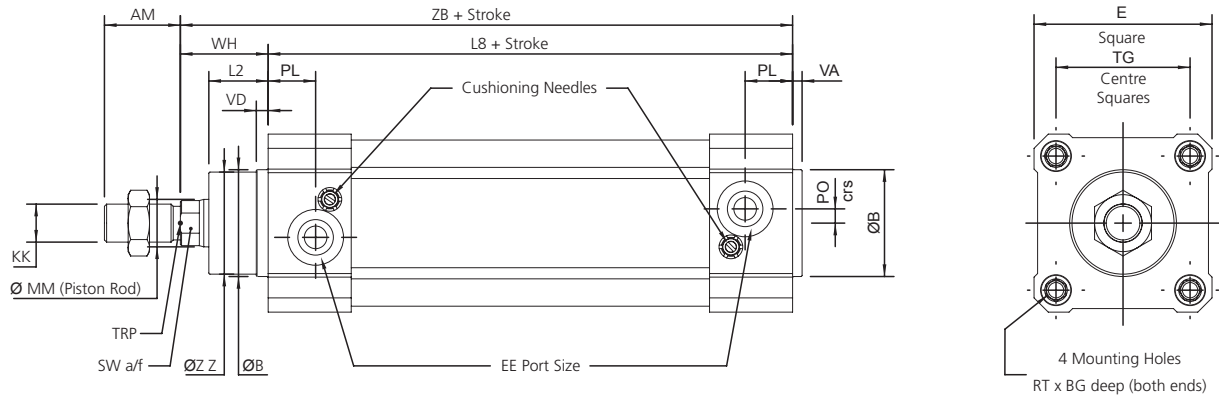

Basic Round Barrel Cylinders

MR****1D*x****

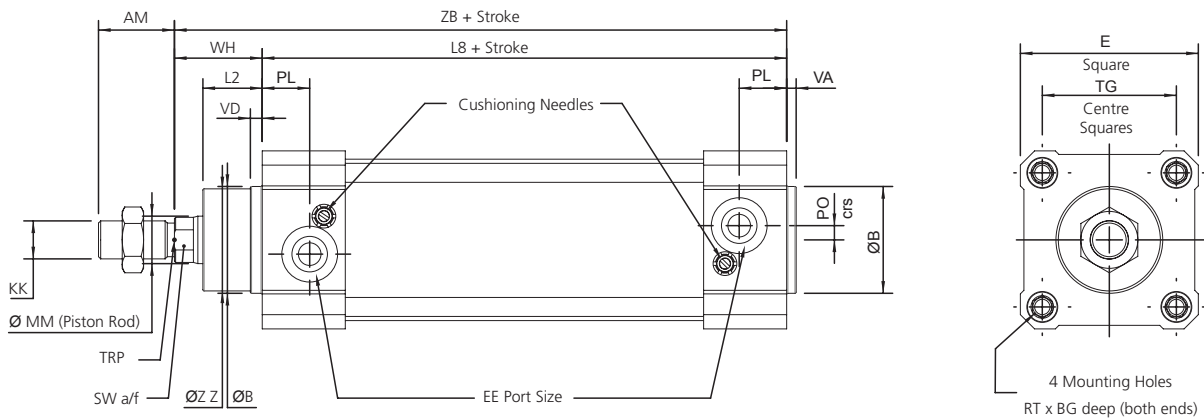

Note: Piston rod locknuts are supplied as standard

Bore	AM	B	BG	E	EE	KK	L2	L8	MM	PL	PO	SW	TG	RT	VA	VD	WH	ZB	ZZ
32	22	30	16	47	G ¹ / ₈ "	M10x1.25	17.5	94	12	13	4.5	10	32.5	M6	4	5	26	120	28
40	24	35	16	52	G ¹ / ₄ "	M12x1.25	20	105	16	14	4.5	13	38	M6	4	5	30	135	33
50	32	40	16	65	G ¹ / ₄ "	M16x1.5	25	106	20	14	6	17	46.5	M8	4	5	37	143	38
63	32	45	16	75	G ³ / ₈ "	M16x1.5	25	121	20	20	6	17	56.5	M8	4	5	37	158	43
80	40	45	18	95	G ³ / ₈ "	M20x1.5	33	128	25	18	7	22	72	M10	4	5	46	174	43
100	40	55	18	115	G ¹ / ₂ "	M20x1.5	38	138	25	20	7	22	89	M10	4	5	51	189	53
125	54	60	20	140	G ¹ / ₂ "	M27x2.0	50	160	32	30	13	27	110	M12	5	6	65	225	59

TRP = Theoretical Reference Point

VDMA/ISO Power Cylinders, Double Acting – 32, 40, 50, 63, 80, 100, 125 mm bore

Cylinder Options

Double Acting through Rod

General Description, Operating Data, Technical Data, Materials of Construction and Service Kits

All data is consistent with that for basic cylinders given on pages 3 and 4.

Preferred Models – Double Acting through Rod Cylinders

Profile Barrel, Magnetic Piston

Bore	Model Code	Mass kg
32 mm	MPE0324DP x Stroke	0.56 + 0.080/25 mm
40 mm	MPE0404DP x Stroke	0.84 + 0.120/25 mm
50 mm	MPE0504DP x Stroke	1.36 + 0.180/25 mm
63 mm	MPE0634DP x Stroke	2.04 + 0.188/25 mm
80 mm	MPE0804DP x Stroke	3.30 + 0.285/25 mm
100 mm	MPE1004DP x Stroke	5.06 + 0.315/25 mm
125 mm	MPE1254DP x Stroke	7.20 + 0.495/25 mm

Round Barrel, Magnetic Piston

Bore	Model Code	Mass kg
32 mm	MRE0324DP x Stroke	0.56 + 0.080/25 mm
40 mm	MRE0404DP x Stroke	0.84 + 0.120/25 mm
50 mm	MRE0504DP x Stroke	1.36 + 0.180/25 mm
63 mm	MRE0634DP x Stroke	2.04 + 0.188/25 mm
80 mm	MRE0804DP x Stroke	3.30 + 0.285/25 mm
100 mm	MRE1004DP x Stroke	5.06 + 0.315/25 mm
125 mm	MRE1254DP x Stroke	7.20 + 0.495/25 mm

Profile Barrel, Non Magnetic Piston

Bore	Model Code	Mass kg
32 mm	MP0324DP x Stroke	0.56 + 0.080/25 mm
40 mm	MP0404DP x Stroke	0.84 + 0.120/25 mm
50 mm	MP0504DP x Stroke	1.36 + 0.180/25 mm
63 mm	MP0634DP x Stroke	2.04 + 0.188/25 mm
80 mm	MP0804DP x Stroke	3.30 + 0.285/25 mm
100 mm	MP1004DP x Stroke	5.06 + 0.315/25 mm

Round Barrel, Non Magnetic Piston

Bore	Model Code	Mass kg
32 mm	MR0324DP x Stroke	0.56 + 0.080/25 mm
40 mm	MR0404DP x Stroke	0.84 + 0.120/25 mm
50 mm	MR0504DP x Stroke	1.36 + 0.180/25 mm
63 mm	MR0634DP x Stroke	2.04 + 0.188/25 mm
80 mm	MR0804DP x Stroke	3.30 + 0.285/25 mm
100 mm	MR1004DP x Stroke	5.06 + 0.315/25 mm

Installation Dimensions mm

Through Rod Profile Barrel Cylinders

MP****4D*x****

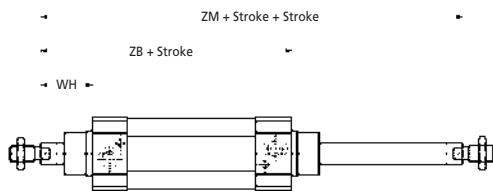

Through Rod Round Barrel Cylinders

MR****4D*x****

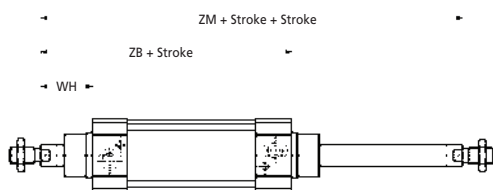

Bore	WH	ZB	ZM
32	26	120	146
40	30	135	165
50	37	143	180
63	37	158	195
80	46	174	220
100	51	189	240
125	65	225	290

All other dimensions as for basic cylinders (see page 8)

Note: Piston rod locknuts are supplied as standard

VDMA/ISO Power Cylinders, Double Acting – 32, 40, 50, 63, 80, 100, 125 mm bore

Cylinder Options (cont'd)

Double Acting Rear Connection. Double Acting Front Connection

General Description, Operating Data, Technical Data, Materials of Construction and Service Kits

All data is consistent with that for basic cylinders given on pages 3 and 4.

Application Note: Rear and front connected cylinders will give 3 or 4 positive positions.

Preferred Models

Double Acting Rear Connection Cylinders

Bore	Model Code	Mass kg
32 mm	M**0325DP x Stroke x Stroke	1.15 + 0.057/25 mm
40 mm	M**0405DP x Stroke x Stroke	1.65 + 0.080/25 mm
50 mm	M**0505DP x Stroke x Stroke	2.70 + 0.116/25 mm
63 mm	M**0635DP x Stroke x Stroke	4.05 + 0.127/25 mm
80 mm	M**0805DP x Stroke x Stroke	6.50 + 0.186/25 mm
100 mm	M**1005DP x Stroke x Stroke	10.10 + 0.218/25 mm

Double Acting Front Connection Cylinders

Bore	Model Code	Mass kg
32 mm	M**0326DP x Stroke x Stroke	1.15 + 0.057/25 mm
40 mm	M**0406DP x Stroke x Stroke	1.65 + 0.080/25 mm
50 mm	M**0506DP x Stroke x Stroke	2.70 + 0.116/25 mm
63 mm	M**0636DP x Stroke x Stroke	4.05 + 0.127/25 mm
80 mm	M**0806DP x Stroke x Stroke	6.50 + 0.186/25 mm
100 mm	M**1006DP x Stroke x Stroke	10.10 + 0.218/25 mm

Note (M**):
 MPE = Magnetic piston, profile barrel
 MRE = Magnetic piston, round barrel
 MP = Non magnetic piston, profile barrel
 MR = Non magnetic piston, round barrel

Installation Dimensions mm

Rear Connection Cylinders

M*****5D*x*****x*****

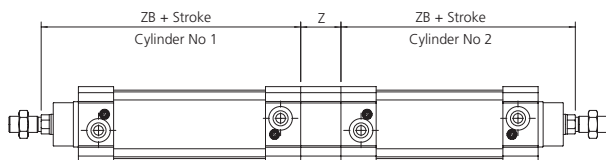

Bore	WH	Z	ZB
32	26	25	120
40	30	30	135
50	37	40	143
63	37	40	158
80	46	50	174
100	51	50	189

All other dimensions as for basic cylinders
(see page 8)

Front Connection Cylinders

M*****6D*x*****x*****

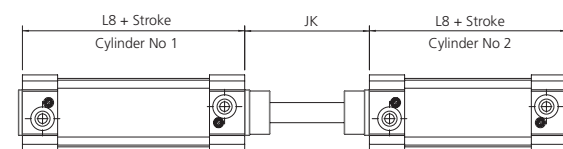

Bore	JK	L2	L8
32	92	17.5	94
40	100	20	105
50	124	25	106
63	124	25	121
80	152	33	128
100	162	38	138

All other dimensions as for basic cylinders
(see page 8)

Note: Piston rod locknuts are supplied as standard.

VDMA/ISO Power Cylinders, Double Acting – 32, 40, 50, 63, 80, 100, 125 mm bore

Cylinder Options (cont'd)

Double Acting High Temperature Cylinders

General Description

All data is consistent with that for basic cylinders given on page 3 but fitted with fluoroelastomer seals.

Operating Fluids

Consistent with that for basic cylinders given on page 3.

Technical Data

Ambient Operating Temperature Range

-10 °C to +150 °C (14 °F to 302 °F)

All other data is consistent with that for basic cylinders given on page 3.

Materials of Construction

Seals

Fluoroelastomer

All other data is consistent with that for basic cylinders given on page 4.

Service Kits

Change code 'P' in position 6 of basic cylinder kits shown on page 4 to code 'V' – i.e. M0321VSK.

Preferred Models

High Temperature Basic Cylinders

Bore	Model Code	Mass kg
32 mm	M**032*DV x Stroke	0.55 + 0.057/25 mm
40 mm	M**040*DV x Stroke	0.83 + 0.080/25 mm
50 mm	M**050*DV x Stroke	1.34 + 0.116/25 mm
63 mm	M**063*DV x Stroke	2.00 + 0.127/25 mm
80 mm	M**080*DV x Stroke	3.25 + 0.186/25 mm
100 mm	M**100*DV x Stroke	5.00 + 0.218/25 mm
125 mm	M**125*DV x Stroke	6.40 + 0.335/25 mm

Note (M**):

MPE = Magnetic piston, profile barrel (32 – 125 mm bore).

MRE = Magnetic piston, round barrel (32 – 125 mm bore).

MP = Non magnetic piston, profile barrel (32 – 100 mm bore).

MR = Non magnetic piston, round barrel (32 – 100 mm bore).

Safety Note

Fluoroelastomer is a synthetic rubber which, if subjected to temperatures above 400 °C (750 °F), changes into a charred or sticky consistency containing Hydrofluoric acid.

This acid is extremely corrosive and once formed remains dangerous for years.

When dealing with components containing the material after a fire or similar very high temperature occurrence it is essential that protective gloves are worn and these are safely disposed of after use.

Installation Dimensions

As for basic cylinders given on page 10.

VDMA/ISO Power Cylinders, Double Acting – 32, 40, 50, 63, 80, 100, 125 mm bore

Cylinder Options (cont'd)

Double Acting Gaitered Cylinders

General Description, Operating Data, Technical Data, Materials of Construction and Service Kits

All data is consistent with that for basic cylinders given on pages 3 and 4.

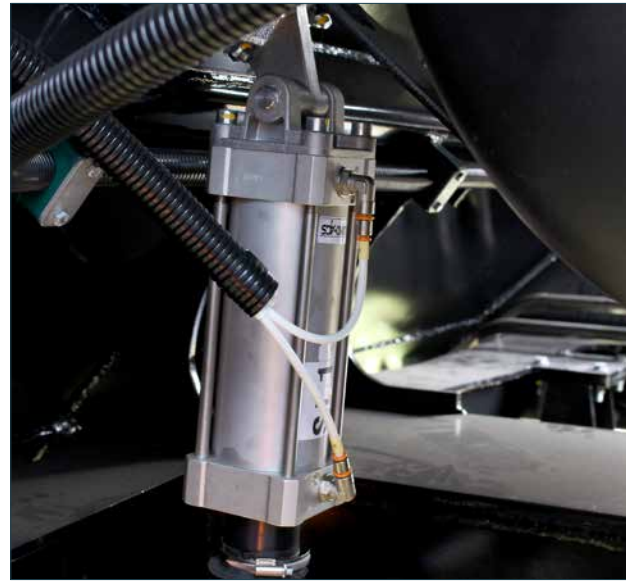

Photo credit: Drax Group Plc

Preferred Models

Basic Gaitered Cylinders

Bore	Model Code	Mass kg
32 mm	M**0321DPG* x Stroke	0.55 + 0.057/25 mm (Cylinder stroke) + 0.25/100 mm (Gaiter length)
40 mm	M**0401DPG* x Stroke	0.83 + 0.080/25 mm (Cylinder stroke) + 0.25/100 mm (Gaiter length)
50 mm	M**0501DPG* x Stroke	1.34 + 0.116/25 mm (Cylinder stroke) + 0.25/100 mm (Gaiter length)
63 mm	M**0631DPG* x Stroke	2.00 + 0.127/25 mm (Cylinder stroke) + 0.25/100 mm (Gaiter length)
80 mm	M**0801DPG* x Stroke	3.25 + 0.186/25 mm (Cylinder stroke) + 0.30/100 mm (Gaiter length)
100 mm	M**1001DPG* x Stroke	5.00 + 0.218/25 mm (Cylinder stroke) + 0.30/100 mm (Gaiter length)
125 mm	M**1251DPG* x Stroke	6.65 + 0.343/25 mm (Cylinder stroke) + 0.30/100 mm (Gaiter length)

Note (M**):
 MPE = Magnetic piston, profile barrel (32 – 200mm bore).
 MRE = Magnetic piston, round barrel (32 – 200mm bore).
 MP = Non magnetic piston, profile barrel (32 – 100mm bore).
 MR = Non magnetic piston, round barrel (32 – 100mm bore).

Installation Dimensions mm

Double Acting Gaitered Cylinders

M*****1D*G*x*****

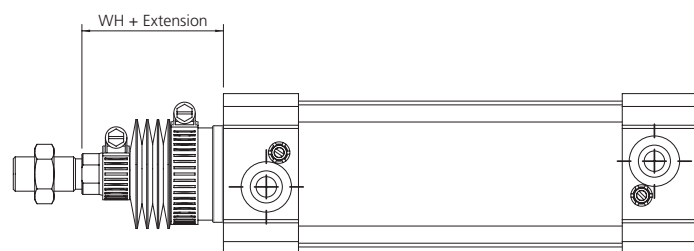

For product dimensions consult Rotork Midland

VDMA/ISO Power Cylinders, Double Acting – 32, 40, 50, 63, 80, 100, 125 mm bore

Cylinder Options (cont'd)

Double Acting Positioner Controlled Cylinders

General Description and Benefits

Pneumatic or electropneumatic positioner units are available which enable the cylinder piston rod to be stroked to any position by varying the signal.

The positioning of the piston rod proportional to the signal can be achieved with accuracy and repeatability of $\leq 0.5\%$ of full stroke.

Operating Fluids

Consistent with that for basic cylinders given on page 3.

Technical Data

Operating Pressure (Cylinder)

1.4 to 10 bar (21 to 150 psi)

Signal Pressure (Pneumatic Unit)

0.2 to 1.0 bar (3 to 15 psi)

Input Signal (Electropneumatic Unit)

4 – 20 mA

Linearity

$\leq 0.5\%$ of full scale

Hysteresis

$\leq 0.5\%$ of full scale

Repeatability

$\leq 0.5\%$ of full stroke

Connection Ports

Screwthread 1/4" BSP

Cam Characteristics

Linear

All other data is consistent with that for basic cylinders given on page 3.

Materials of Construction

Positioner Housing

Die cast aluminium

Surface Treatment

ED Epoxy paint, black

Ingress Protection

IP66 / NEMA 4

All other data is consistent with that for basic cylinders given on page 4.

Service Kits

Details given on page 4.

Preferred Models – Double Acting Positioner Controlled Cylinders

Electropneumatic Control Unit

Bore	Model Code	Mass kg
40 mm	M**0408DP ^{††} x Stroke	2.33 + 0.080/25 mm
50 mm	M**0508DP ^{††} x Stroke	2.84 + 0.116/25 mm
63 mm	M**0638DP ^{††} x Stroke	3.50 + 0.127/25 mm
80 mm	M**0808DP ^{††} x Stroke	4.75 + 0.186/25 mm
100 mm	M**1008DP ^{††} x Stroke	6.50 + 0.218/25 mm
125 mm	M**1258DP ^{††} x Stroke	7.90 + 0.335/25 mm

Pneumatic Control Unit

Bore	Model Code	Mass kg
40 mm	M**0409DP ^{††} x Stroke	1.93 + 0.080/25 mm
50 mm	M**0509DP ^{††} x Stroke	2.44 + 0.116/25 mm
63 mm	M**0639DP ^{††} x Stroke	3.10 + 0.127/25 mm
80 mm	M**0809DP ^{††} x Stroke	4.35 + 0.186/25 mm
100 mm	M**1008DP ^{††} x Stroke	6.10 + 0.218/25 mm
125 mm	M**1259DP ^{††} x Stroke	7.50 + 0.335/25 mm

Note (M**): MPE = Magnetic piston, profile barrel.
MRE = Magnetic piston, round barrel.

Note (††): CE = Cam extends with increase in signal pressure.
CR = Cam retracts with increase in signal pressure.

VDMA/ISO Power Cylinders, Double Acting – 32, 40, 50, 63, 80, 100, 125 mm bore

Installation Dimensions mm

Double Acting Positioner Controlled Cylinders

M*****8D*G*x****

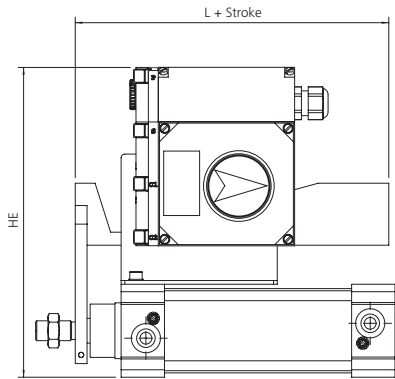

M*****9D*G*x****

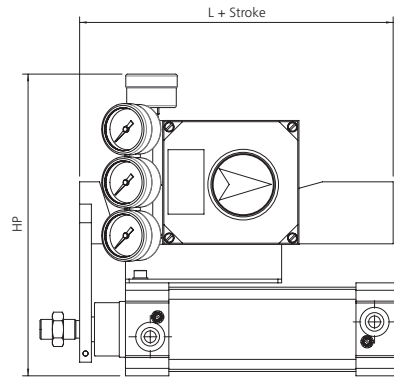

RH assembly standard as shown, please state if LH assembly required.

Feedback unit and I/P Converter available for pneumatic units.

Explosion Proof, Intrinsically Safe and Fail Freeze versions available for electropneumatic units.

Details of these and other variants on application.

Bore	HE	HP	L(RH)	L(LH)
40	237	227	133	233
50	253	243	140	240
63	263	253	140	240
80	286	276	146	246
100	314	304	158	258
125	335	325	180	280

All other dimensions as for basic cylinders (see page 8)

VDMA/ISO Power Cylinders, Double Acting – 32, 40, 50, 63, 80, 100, 125 mm bore

Mountings

Front (MF1) and Rear (MF2) Flange – to VDMA 24562 and ISO 6431

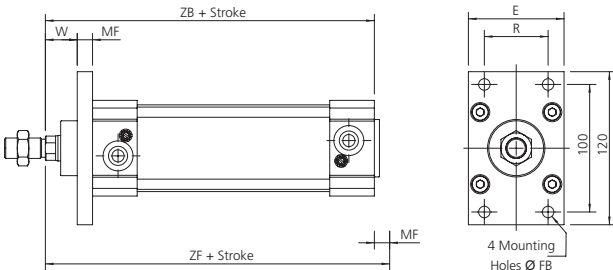

Model Code, Installation Dimensions in mm

Bore	Kit Number	E	FB	MF	R	TF	UF	W	ZB	ZF
32	M032 - MF1K	50	7	10	32	64	80	16	120	130
40	M040 - MF1K	55	9	10	36	72	90	20	135	145
50	M050 - MF1K	65	9	12	45	90	110	25	143	155
63	M063 - MF1K	75	9	12	50	100	120	25	158	170
80	M080 - MF1K	95	12	16	63	126	153	30	174	190
100	M100 - MF1K	115	14	16	75	150	178	35	189	205
125	M125 - MF1K	140	16	20	90	180	220	45	225	245

- Note: 1. Kit number M*** – MF1K is suitable for front or rear fitment.
 2. Kit supplied complete with fixing screws.
 3. Material of construction – Mild Steel, Zinc plated.

Feet (MS1) – to VDMA 24562 and ISO 6431

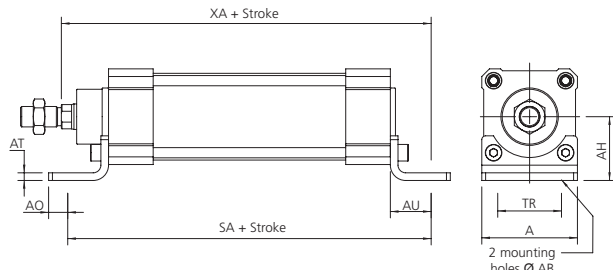

Model Code, Installation Dimensions in mm

Bore	Kit Number	A	AB	AH	AO	AT	AU	SA	TR	XA
32	M032 - MS1K	45	7	32	11	5	24	142	32	144
40	M040 - MS1K	52	9	36	15	5	28	161	36	163
50	M050 - MS1K	65	9	45	15	6	32	170	45	175
63	M063 - MS1K	75	9	50	15	6	32	185	50	190
80	M080 - MS1K	95	12	63	20	7	41	210	63	215
100	M100 - MS1K	115	14	71	25	7	41	220	75	230
125	M125 - MS1K	140	16	90	15	8	45	250	90	270

- Note: 1. Kit M*** – MS1K is supplied as a pair.
 2. Kit supplied complete with fixing screws.
 3. Material of construction – Mild Steel, Zinc plated.

Rear Clevis (MP2) – to VDMA 24562 and ISO 6431

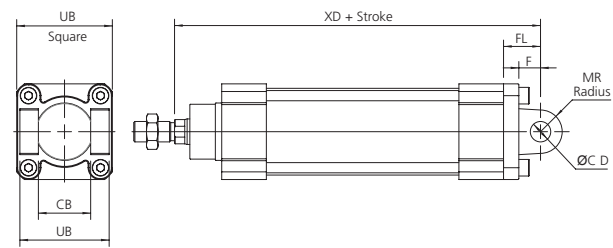

Model Code, Installation Dimensions in mm

Bore	Kit Number	CB	CD	E	FL	L	MR	UB	XD
32	M032 - MP2K	26	10	45	22	12	11	45	142
40	M040 - MP2K	28	12	52	25	15	13	52	160
50	M050 - MP2K	32	12	65	27	15	13	60	170
63	M063 - MP2K	40	16	75	32	20	17	70	190
80	M080 - MP2K	50	16	95	36	20	17	90	210
100	M100 - MP2K	60	20	115	41	25	21	110	230
125	M125 - MP2K	70	25	140	50	30	26	130	275

- Note: 1. Pivot pin is supplied separately – see page 17.
 2. Kit supplied complete with fixing screws.
 3. Material of construction – Aluminium.

VDMA/ISO Power Cylinders, Double Acting – 32, 40, 50, 63, 80, 100, 125 mm bore

Mountings (cont'd)

Rear Eye (MP4) – to VDMA 24562 and ISO 6431

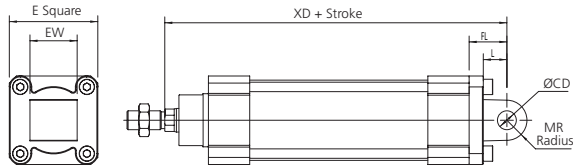

Model Code, Installation Dimensions in mm

Bore	Kit Number	CD	E	EW	FL	L	MR	XD
32	M032 - MP4K	10	45	26	22	12	11	142
40	M040 - MP4K	12	52	28	25	15	13	160
50	M050 - MP4K	12	65	32	27	15	13	170
63	M063 - MP4K	16	75	40	32	20	17	190
80	M080 - MP4K	16	95	50	36	20	17	210
100	M100 - MP4K	20	115	60	41	25	21	230
125	M125 - MP4K	25	140	70	50	30	26	275

- Note: 1. Pivot pin is supplied separately – see page 17.
 2. Kit supplied complete with fixing screws.
 3. Material of construction – Aluminium.

Rear Hinge Mount (MP2 + MP4 + Pivot Pin) – to VDMA 24562 and ISO 6431

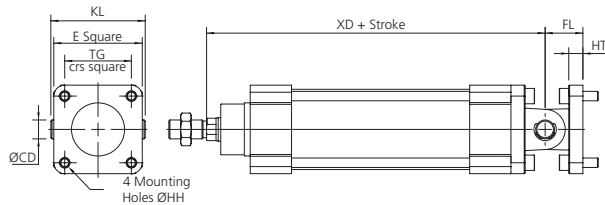

Model Code, Installation Dimensions in mm

Bore	Kit Number	CD	E	FL	HH	HT	KL	TG	XD
32	M032 - MP24K	10	45	22	7	10	53	32.5	142
40	M040 - MP24K	12	52	25	7	10	60	38	160
50	M050 - MP24K	12	65	27	9	12	69	46.5	170
63	M063 - MP24K	16	75	32	9	12	80	56.5	190
80	M080 - MP24K	16	95	36	11	16	101	72	210
100	M100 - MP24K	20	115	41	11	16	121	89	230
125	M125 - MP24K	25	140	50	14	20	142	110	275

- Note: 1. Kit supplied complete with fixing screws.
 2. Material of construction – Aluminium.

Rear 90° Hinge (MP2 + 90° Bracket + Pivot Pin) – to VDMA 24562 and ISO 6431

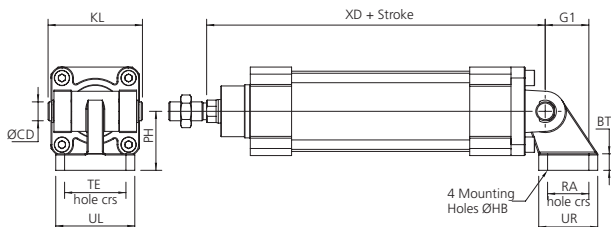

Model Code, Installation Dimensions in mm

Bore	Kit Number	BT	CD	G1	HB	KL	PH	RA	TE	UL	UR	XD
32	M032 - MP29K	8	10	21	6.6	53	32	18	38	51	31	142
40	M040 - MP29K	10	12	24	6.6	60	36	22	41	54	35	160
50	M050 - MP29K	12	12	33	9	69	45	30	50	65	45	170
63	M063 - MP29K	14	16	37	9	80	50	35	52	67	50	190
80	M080 - MP29K	14	16	47	11	101	63	40	66	86	60	210
100	M100 - MP29K	17	20	55	11	121	71	50	76	96	70	230
125	M125 - MP29K	20	25	70	14	142	90	60	94	124	90	275

- Note: 1. Kit supplied complete with fixing screws.
 2. Material of construction – Aluminium and Mild Steel, Zinc plated.

VDMA/ISO Power Cylinders, Double Acting – 32, 40, 50, 63, 80, 100, 125 mm bore

Mountings (cont'd)

Intermediate Trunnion (MT4) – to VDMA 24562 and ISO 6431 (Available for round barrel models ONLY)

Trunnion pins are positioned at 90° to cylinder ports.
XO = reference dimension at zero stroke.

Model Code, Installation Dimensions in mm

Bore	Model Code	L	TD	TL	TM	UW	XO	XV (min)	XV (max)
32	MR*0321DPMT4 x stroke	20	12	12	50	46	73	64.5	Stroke + 81.5
40	MR*0401DPMT4 x stroke	20	16	16	63	58	82.5	75	Stroke + 90
50	MR*0501DPMT4 x stroke	20	16	16	73	68	90	80	Stroke + 100
63	MR*0631DPMT4 x stroke	30	20	20	90	84	97.5	90	Stroke + 105
80	MR*0801DPMT4 x stroke	30	20	20	108	102	110	100	Stroke + 120
100	MR*1001DPMT4 x stroke	30	25	25	131	124	120	110	Stroke + 130
125	MR*1251DPMT4 x stroke	30	25	25	159	152	145	130	Stroke + 150

Note (M**): MRE = Magnetic piston, round barrel (32 – 200 mm bore).
MR = Non Magnetic piston, round barrel (32 – 100 mm bore).

Notes

- When ordering, cylinder and trunnion must be ordered together and dimension XV **MUST** be specified. All cylinders will be given a unique SCM part number for dimensional traceability, if not mounted in central position.
- Trunnion supplied in central position as standard XV = 1/2 stroke + XO.
- XV variations from the central position are supplied to special order – minimum and maximum permitted values are given in dimension table above.
- When trunnion is in extreme front or rear position magnetic sensors (if fitted) will not detect end of stroke at trunnion location.
- For twin cylinders of unequal stroke customer must specify which cylinder is to be fitted with trunnion mounting.

VDMA/ISO Power Cylinders, Double Acting – 32, 40, 50, 63, 80, 100, 125 mm bore

Accessories

Fork End with lockable Pivot Pin (32 – 100 mm), Fork End with Pivot Pin (125 mm)

32 – 100 mm

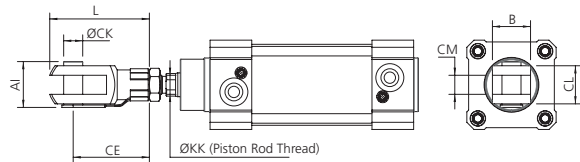

125 – 200 mm

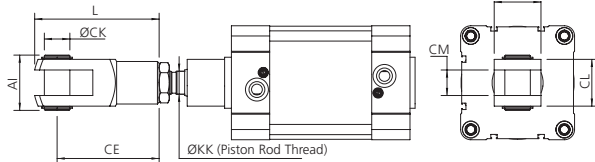

Model Code, Installation Dimensions in mm

Bore	Kit Number	AI	B	CE	CK	CL	CM	KK	L
32	M032 - FEK	26	20	40	10	20	10	M10x1.25	52
40	M040 - FEK	32	24	48	12	24	12	M12x1.25	62
50 & 63	M050 - FEK	38	32	64	16	32	16	M16x1.5	83
80 & 100	M080 - FEK	48	40	80	20	40	20	M20x1.5	105
125	M125 - FEK	65	55	100	30	55	30	M27x2.0	148

Note: 1. Piston rod locknut provided as standard with cylinder.
2. Material of construction – Mild Steel, Zinc plated.

Rod Spherical Bearing – to ISO 8140

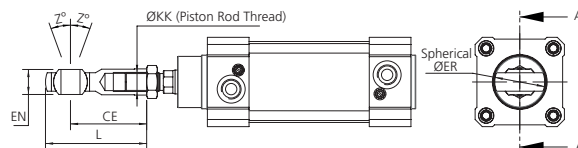

Model Code, Installation Dimensions in mm

Bore	Kit Number	CE	CN	EN	ER	KK	L	Z°
32	M032 - SREK	43	10	14	28	M10x1.25	57	6.5°
40	M040 - SREK	50	12	16	32	M12x1.25	66	6.5°
50 & 63	M050 - SREK	64	16	21	42	M16x1.5	85	7.5°
80 & 100	M080 - SREK	77	20	25	50	M20x1.5	102	7°
125	M125 - SREK	110	30	37	70	M27x2.0	145	8.5°

Note: 1. Piston rod locknut provided as standard with cylinder.
2. Material of construction – Mild Steel, Zinc plated.

VDMA/ISO Power Cylinders, Double Acting – 32, 40, 50, 63, 80, 100, 125 mm bore

Accessories (cont'd)

Pivot Pin

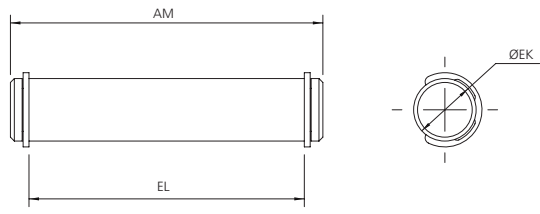

Pivot pin is supplied complete with retaining clips

Model Code, Installation Dimensions in mm

Bore	Kit Number	AM	EK	EL
32	M032 - PPK	53	10	46
40	M040 - PPK	60	12	52
50	M050 - PPK	69	12	61
63	M063 - PPK	80	16	71
80	M080 - PPK	101	16	91
100	M100 - PPK	121	20	111
125	M125 - PPK	142	25	132

Piston Rod Locknut

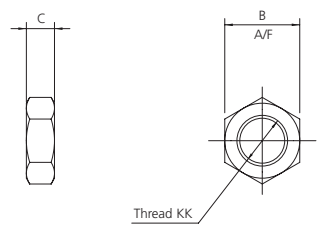

Model Code, Installation Dimensions in mm

Bore	Kit Number	B	C	KK
32	M032 - 9	17	6	M10x1.25
40	M040 - 9	19	7	M12x1.25
50 & 63	M050 - 9	24	9	M16x1.5
80 & 100	M080 - 9	30	10	M20x1.5
125	M125 - 9	41	12	M27x2

VDMA/ISO Power Cylinders, Double Acting – 32, 40, 50, 63, 80, 100, 125 mm bore

Magnetic Sensors

Reed Switch

General Description

Reed switches with LED indicator and miniature 90° connector with 2 metre flying lead.

Switch is fitted to the profile barrel by means of an adaptor clamp or to the cylinder tie rods by means of a clamp assembly.

Circuit Diagrams of Switches

Reed switch

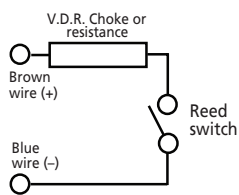

⚠ WARNING:

For cable runs over 5m protect switch from inrush either by using a 680mh choke or a resistor fitted in series. For inductive loads a voltage dependent resistor with a higher clamping voltage than the supply must be used. Protection must be fitted within 2m of the switch.

Technical Data

Ambient Operating Temperature Range

-30 °C to + 80 °C (-22 °F to + 176 °F)

Contact Function

Normally open

Protection

IP65

Nominal Voltage

3 – 250 VDC

3 – 250 VAC

Switching Current

1000 mA

Maximum Power

50 W / 50 VA

Switch ON Time

2 milliseconds

Switch OFF Time

0.1 milliseconds

Electrical Life

10 x 10⁶ cycles

Resistance to Vibration

1000 Hz

Magnetic Field

Intensity decreased by 2% for every 10 °C (18 °F) rise in operating temperature

Coating Material

PA + 30% GF

Led Indication

Red - 'ON'

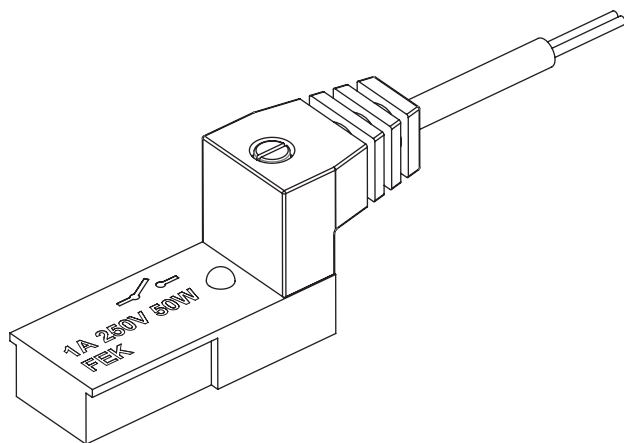

VDMA/ISO Power Cylinders, Double Acting – 32, 40, 50, 63, 80, 100, 125 mm bore

Magnetic Sensors (cont'd)

Preferred Models

Reed Switch

Code	Description
FEK110AORP2	Reed switch with miniature 90° connector

Fixings

Code	Description
FA51-1131	Adaptor clamp for profile tube (32 mm – 40 mm bore cylinders)
FA51-1232	Adaptor clamp for profile tube (50 mm bore cylinders)
FA51-1237	Adaptor clamp for profile tube (63 mm – 80 mm bore cylinders)
FA51-1337	Adaptor clamp for profile tube (100 mm – 125 mm bore cylinders)
FA51-1437	Adaptor clamp for profile tube (160 mm – 200 mm bore cylinders)
FA44-0009	Tie rod clamp (32 mm – 63 mm bore cylinders)
FA44-0015	Tie rod clamp (80 mm – 125 mm bore cylinders)

Installation Dimensions mm

Reed Switch

FEK110AORP2

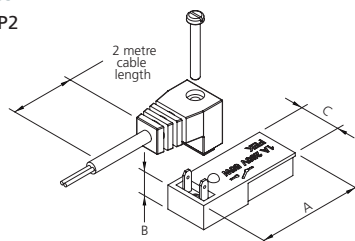

Model	A	B	C
FEK110AORP2	33	7.4	12.9

Shaped Profile Barrel Clamp

FA51-****

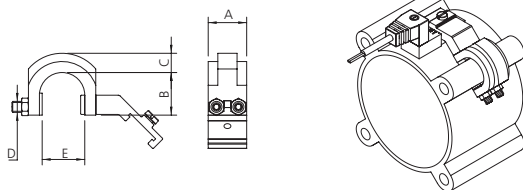

Model	A	B	C	D	E
FA51-1131	14	12	6	M4 x 10	12.2
FA51-1232	14	15.5	7	M4 x 10	15.5
FA51-1237	14	15.5	7	M4 x 10	15.5
FA51-1337	14	19.5	7	M4 x 20	20
FA51-1437	14	23	7	M4 x 20	26

Tie Rod Clamp

FA44-****

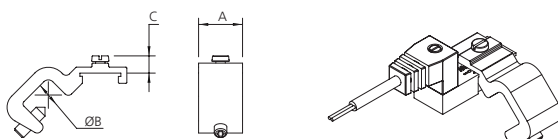

Model	A	B (min)	B (max)	C (max)
FA44-0009	14	4	9	5.5
FA44-0015	14	9	15	5.5
FA44-0020	14	15	20	5.5

Oil & Gas industries

rotork® MIDLAND

Since our founding in 1956, we have been known internationally as one of the oil & gas industries premier designers and manufacturers of 316L stainless steel control equipment. Over the years we have developed an enviable reputation for high quality products, reliability and innovation.

We have the ability to investigate problems and provide comprehensive solutions for the control of hydraulic and pneumatic actuated process control valves across a broad range of industries and markets. This, coupled with repeatedly delivering impressive results worldwide, sets us apart from our competitors.

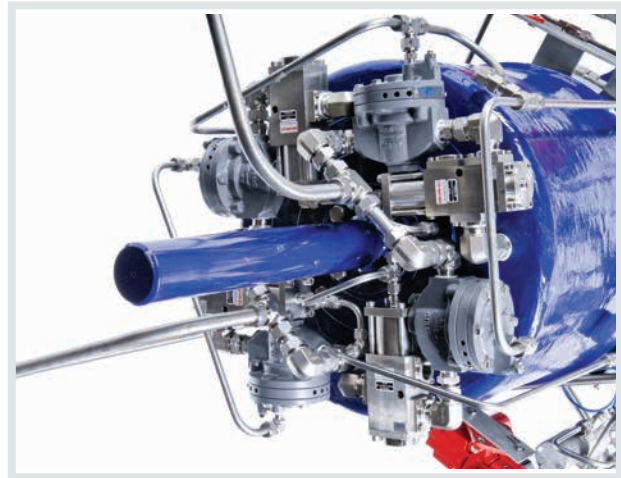

rotork® Instruments

Rotork Instruments are experts in flow control, pressure control, flow measurement and pressure measurement.

We manufacture products and components that are trusted for applications where high precision and reliability are required.

Rotork Instruments has manufacturing facilities in USA, Italy, Brazil, India, China and Singapore.

The Rotork global sales and service network supports all Rotork Instruments products. This network is the biggest global actuation support organisation in the world with direct sales offices and agents in all industrialised countries.

Customer service and field support provides quick and effective response to customer requirements.

The Rotork Site Services network is represented throughout the world and provides valuable service and assistance to all industries.

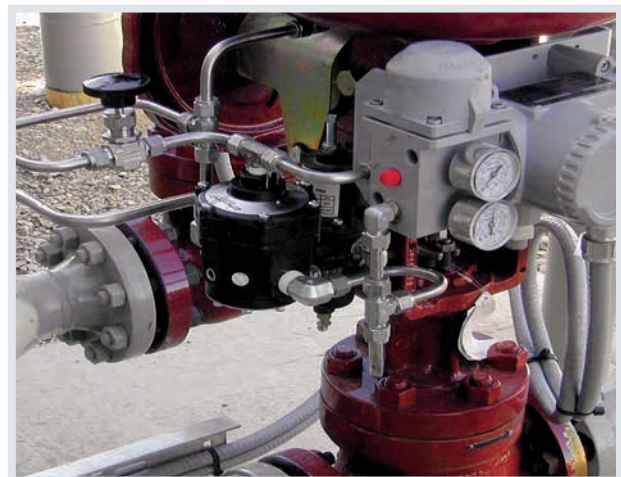

Service and Support

rotork® Site Services

In each of our divisions, Site Services staff are dedicated to providing customer service and support, carrying out new installations and delivering retrofit projects. These teams are based out of service centres around the world and are complemented by factory-trained agents.

Our expert technicians support Rotork customers, allowing us to deliver on our promise of global solutions backed by local service.

Visit www.rotork.com to identify your nearest Rotork location.



Client Support Programme

Rotork offers a premium level of product reliability and availability through the flexible Client Support Programme (CSP). Designed to facilitate the highest production demands while providing a tiered approach to maintenance, the CSP is committed to reducing maintenance downtime and costs.

Through consultation, the CSP is tuned to deliver the optimum level of maintenance through predictive maintenance algorithms.

Features of the CSP are:

- Fixed term prices for Rotork products and services
- Customisable cover based on equipment criticality to production
- Equipment performance related targets for reliability and availability
- Priority support with customisable response times
- Fully parts and labour inclusive, no additional costs or discounted labour and parts
- Fix or replace options
- Periodic equipment performance and status reports
- Built-in regular health checks on all equipment

Benefits of the CSP include but are not limited to:

- Year-on-year reduced maintenance costs
- Easy budget management
- Maximised production resulting in reduced downtime
- Year-on-year improved reliability and availability
- Optimised resource usage to accelerate in-house projects
- Reduced lifecycle costs





Keeping the World Flowing

A dark blue background featuring a stylized world map with a white grid of latitude and longitude lines.

www.rotork.com

A full listing of our worldwide sales and service network is available on our website.

Rotork Midland Ltd.
Patrick Gregory Road
Wolverhampton
WV11 3DZ, UK
tel +44 (0)1902 305 678
fax +44 (0)1902 305 676
email sales.midland@rotork.com

Rotork is a corporate member of the Institute of Asset Management



PUB117-014-00
Issue 02/16

As part of a process of on-going product development, Rotork reserves the right to amend and change specifications without prior notice. Published data may be subject to change. For the very latest version release, visit our website at www.rotork.com
The name Rotork is a registered trademark. Rotork recognises all registered trademarks. POWJB1215.
Published and produced in the UK by Rotork Controls Limited. Registered office: Rotork plc, Brassmill Lane, Bath, BA1 3JQ, UK.