

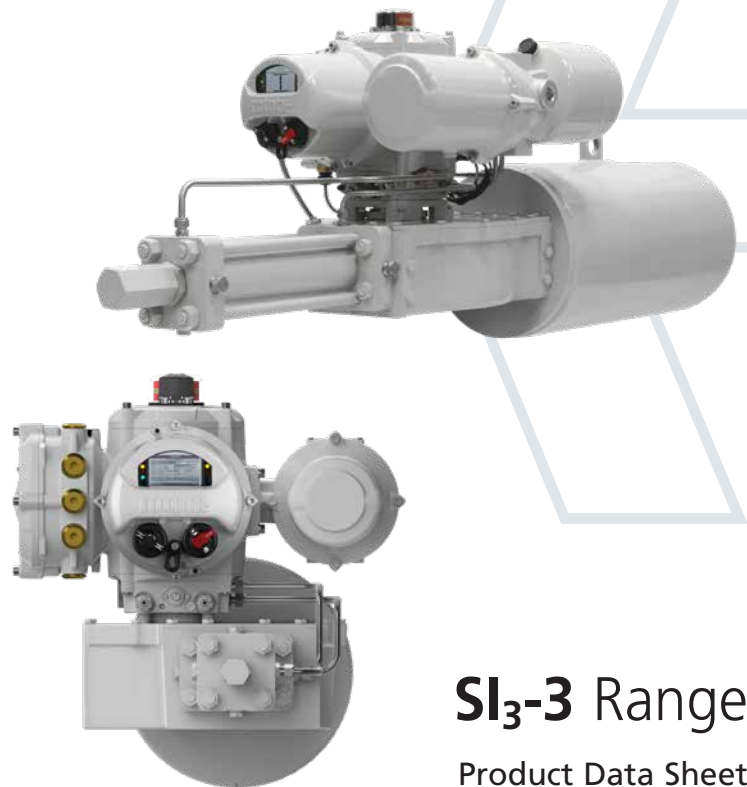

Keeping the World Flowing
for Future Generations



SI₃-3 Range

Product Data Sheet

SI₃-3 Range Actuators

With Rotork's continuous development and improvement policy and to meet new applications and customer needs. Rotork has introduced the 3rd generation of SI actuators. The SI₃ range of self-contained electro hydraulic actuators includes the addition of the SI₃-3 quarter-turn actuators, designed as spring-return with a standard range of torques from 2,000 Nm to 30,000 Nm.

Designed for Safety Instrumented Systems to safe guard life, the environment and the process plant. The SI₃ provides a reliable means of positioning a valve or damper in the safe position (fail-safe) on loss of power supply, ESD or control signal.

With over 30 years experience in manufacturing electro-hydraulic actuators, the SI₃-3 range have been specifically designed to meet today's control and safety needs for both two-position and positioning control applications. The actuators are offered with a wide range of operating speeds, ESD input options, partial stroke testing, analogue, HART and fieldbus communication capabilities to comply with all control configurations.

Typical Applications

- Oil & Gas onshore and offshore production facilities
- Remote wellhead shutdown and choke valve control
- Pipelines shutdown
- Storage facilities
- Ship & road tanker loading systems
- Ballast systems
- Metering systems
- By-pass control
- Reservoir level control
- Flood water systems

For higher spring-return torques or where accumulators are preferred as the form of stored energy Rotork offer the SI₃-4 actuator range.

The SI₃-4 Electro-hydraulic actuators available:

- Spring-return up to 154,000 Nm
- Double-acting up to 400,000 Nm double-acting



SI₃-3 Range Actuators

The Skilmatic SI₃-3 quarter-turn actuators have been designed for fail safe spring-return applications where functional safety is paramount. The actuators are suitable for use in Safety Instrumented Systems (SIS), certified to IEC 61508:2010.

The SI₃-3 can be supplied fail close, open or in last position on loss of Emergency Shutdown (ESD) signal and when selected on loss of power supply. Independent limit switches and position feedback are provided and selectable status and alarm indication with volt free relay outputs are also offered as standard.

The SI₃-3 are compact, robust and sealed to the environment watertight to IP66/68. They can be supplied certified for hazardous areas Zone 1 or Division 1.

The actuators are provided with a dual stacked LCD display, data logging, diagnostic capabilities and Bluetooth connectivity to download the historical data such as events, trends and status.

To maintain the integrity of the enclosure, Rotork non-intrusive infra-red / Bluetooth® setting tool is supplied to allow for viewing settings and to download the actuator data without the removal of any actuator covers.

Key Benefits of the SI₃ Actuators

- Fail-safe, closed, open or in last position.
- Only requires electrical power
- Hazardous area certified Ex d IIB/IIC T4 and watertight IP66/68
- ESD /PSD options including dual inputs and various solenoid configurations
- Functional Safety SIL2 & SIL3 to IEC 61508:2010
- Advanced dual stacked display presents valve and process data for asset management and data analysis
- Non-intrusive setting – no cover removal required using secure Bluetooth wireless connection
- Datalogger- capable of storing up to 3,000 events
- Partial Stroke Test (PST) based on time and position with pressure (torque) logged
- Partial Stroke Tests (PST) initiated via Bluetooth® Setting Tool, hardwired or remotely through network cards
- PST results displayed on the screen and recorded in the data logger with the last 25 PST results.
- Configurable status and alarms with optional outputs
- 4-20 mA Positioning control resolution to 0.3%
- Increased functionality over network cards including Pakscan™, Profibus®, Foundation Fieldbus® Modbus® and HART®
- Operating temperatures -50 to +70°C

3rd Generation Feature

The SI range of actuators consist of a sealed control module with the LCD dual display located behind a sealed toughened glass window. Set-up and reviewing the configuration is undertaken with the Rotork Bluetooth setting tool, making the actuators ideal for use in hazardous and harsh environments. The non-intrusive Bluetooth handheld setting tool provides access to internal hydraulic pressure settings, position limits, control, indication functions and the datalogger. The setting tool is also compatible with older models of Rotork infra-red setting tools. The 3rd generation SI range can operate using the Rotork Bluetooth® Setting Tool *Pro*, allowing access without direct line of sight over greater distances. This is achieved by pairing the setting tool and actuator in a single infra-red transaction after which Bluetooth wireless connection can take over. Configuration changes are password protected and the actuator is immune to connection by non- Rotork devices or programmes.

The 3rd generation of SI actuators benefit from further advances in human interface design. In addition to a configurable, information rich display, the actuators provide a highly intuitive menu structure for commissioning and diagnostics.

The latest version of the Rotork Insight software streamlines actuator set-up. The settings can be saved on a suitable PC and quickly downloaded to the individual actuators via the handheld Rotork Bluetooth® Setting Tool. Insight allows the operator to review settings, events and trends on a PC remote from the actuator.

Double-Sealed Terminal Compartment

The SI actuator control modules are rated to IP 66/68 watertight and dust tight. The terminal compartment is designed with a double-seal to ensure protection of all internal components by separating them from the cable glands and terminal compartment with a sealed watertight terminal block. Protection is maintained during site installation when the terminal cover is removed and is independent of cable gland sealing. The terminal compartment is available as watertight or hazardous area certified Ex d or Ex e.



SI₃ Features

Local Control and Indication

Non-intrusive selectors are provided on the actuators electrical control module cover which also includes an LCD display showing actuator position, status and alarm. The control module cover may be rotated through 360° (90° increments) to suit actuator orientation/operator access. Set-up is over a Bluetooth wireless interface using the supplied Rotork Bluetooth® Setting Tool *Pro*.

Display

The LCD dual stacked display allows large segment characters for position and pressure to be displayed down to -50 °C (-58 °F), while the matrix display provides detailed setting, status and diagnostic screens. Overall the display is 30% bigger, is backlit to provide excellent contrast even in the brightest ambient light conditions and is protected by a toughened glass window.

An optional protective clip-in cover is available where high UV levels or abrasive environments are present.

Position Indicator LED's

Within the display window position indication LEDs are supplied in duplicate on each side of the display to indicate end of travel limits (open and closed) and intermediate position.

Local Controls

The control module is complete with local lockable controls. The Local/Stop/Remote selector switch and open/close switch are non-intrusive, coupled magnetically to the designated switch, thereby maintaining the module sealed to the environment. The open/close switch can only be operated when local is selected.



Pressure and Position Monitoring

The actuator torque is measured in the form of hydraulic pressure which directly relates to the torque required to operate the valve.

The SI₃ actuator monitors the valve position and torque. The signals are used by the actuator control circuit to limit position and pressure. They also provide real time indication, alarms and record valve operating profiles to the internal datalogger with date and time stamped.

Pressure

The hydraulic pressure sensor is integral to the actuator control module and monitors the pressure generated to overcome the valve force throughout the actuator stroke.

The pressure sensor will detect obstructions in mid-travel and will alarm should a high pressure be detected. The actuator can torque seat a valve at either end of travel. When torque seating is required an option is included for the system to maintain the internal hydraulic pressure by re-starting the motor/pump automatically if the pressure drops below the required pressure.

Hysteresis adjustment for over- and under- pressure can be enabled to compensate for hydraulic expansion or contraction due to large ambient temperature changes.

Position

Reliable valve position monitoring is critical in all remote valve automation applications constantly monitoring the position throughout the valve stroke. The monitoring system needs to provide the actuator controls with continuous position information.

The SI₃ monitors the position through a high resolution non contacting Hall Effect sensor incorporated within the actuator control module. The sensor is designed for high duty cycling with minimum moving parts and is directly connected to the valve drive shaft to provide a resolution < 0.25%. The actuator display will read position as 0.0% at the closed limit and 100.0% at the open limit.

Position feedback can be provided as a 4-20 mA output signal.

The actuator is capable of setting the open and closed limits on position or hydraulic pressure (torque).

Local Mechanical Indicator

The SI₃ actuator can be provided with mechanical position indication, visible at over 10 meters from the actuators. The red and green visual indicator can be provided with either UV resistant polycarbonate or 316 stainless steel indicator.

SI₃ Features

Control

The actuator can be configured for remote control of a valve or damper in two position or positioning control applications. Available to meet the requirements of various site control systems from simple manual push-button control, remote two position control, emergency shutdown (ESD) through to positioning control using hardwired switched signals, analogue or digital "bus" network systems.

Hardwired two position control can be selected as 2 or 3 wire control – Open, Close and Maintain commands with emergency shutdown and partial stroke testing configurable as standard.

Stepping control to slow the rate of opening and / or closing over part or the full stroke of the valve can be selected to reduce pressure surges in the valve and pipeline. The stepping option is selected in the menu and the required stepping control travel, stroke time and number steps are set in the menu.

Emergency Shutdown – (ESD)

The Skilmatic SI₃-3 has been designed for fail safe applications where Functional safety is paramount. The actuators are suitable for use in Safety Instrumented Systems (SIS), certified to IEC 61508:2010. For use in SIL 2 & SIL 3 systems.

When used for a fail-safe application the SI₃ can be configured through hardware selection to accept an ESD input as part of a SIS. In this configuration the actuator will only operate when the actuator detects a safe ESD input signal and will trip on loss of the signal. The actuator can be provided to operate in the following ESD modes.

Fail-safe on Loss of Mains Supply

For applications where the loss of mains power is considered part of the Safety Instrumented System the SI₃ is offered as Fail Safe on either loss of power supply or ESD signal. This option offers a low power consumption on the ESD input (0.2 W). In this mode the solenoid valve(s) that perform the safety function are powered from the main power supply circuit, the actuator will accept an ESD input signal of 20 to 60 VDC or 60 to 120 VAC with the following functionality:

- Fail-safe on loss of ESD signal
- Fail-safe on loss of mains power supply

Fail-in-Position on Loss of Mains Supply

For applications where the mains power is unreliable and is not critical to the functional safety of the process, the SI₃ can be offered for fail-safe on loss of ESD signal and will comply with IEC 61508. In this mode the solenoid valve(s) that perform the safety function will require to be powered from a 24 VDC ESD input and will operate through a PWM circuit to reduce the power consumption. This option will provide the following functionality.

- Fail-safe on loss of ESD signal
- Fail in last position on loss of mains power supply

Additional ESD Input

The standard fail safe configuration of the SI₃ actuator will accept a single ESD input. The SI₃ offers the option of a second ESD input by using an additional ESD option card. This allows the SI₃ to operate with two shutdown systems such as emergency shutdown ESD system and a Process shutdown from a DCS system without affecting the integrity of the safety system with the following functionality:

- Two ESD signals operate common solenoid valve(s). If either ESD signal is removed the actuator will perform the safety function by operating the same final elements.
- Two ESD signals operating independent solenoid valve(s). If either ESD signal is removed then the actuator will perform the safety function by operating the associated solenoid valve.



SI₃ Features

ESD Manual Reset

When an ESD signal has tripped and the actuators has moved to the safe position, the actuator will only operate when the ESD signal is reinstated and a new command signal is provided.

As an added protection layer the SI₃ has an option, selected in the menu to manually reset the actuator before the actuator can accept a new command signal. The manual reset can be operated by the local controls on the actuator control module which will act as reset switch or by a remote reset pushbutton supplied by the customer and wired to the actuators.

Partial Stroke Testing (PST)

Partial Stroke Testing is a function used in two position safety critical applications where the safety valve is infrequently operated. PST allows the operator to test critical components in the actuator and valve for possible failure. The test can be performed without the need to physically close the valve and thereby maintain the process operational. This allows the user to identify any potential faults which could prevent the actuated valve from performing its safety function.

All final elements such as solenoids, actuator drive and the shutdown valve are tested during the Partial Stroke Test.

The SI₃ range of actuators provide partial stroke testing as a standard option on all two position configurations. When the command is given to initiate the test, the actuator will move the valve to a pre-set position and the stroke time recorded.

The advanced PST system operates by de-energising each solenoid valve in turn to allow the valve to move to the required position and then return the valve to the original position. The degree of movement required is configured by the user during the commissioning process and is adjustable from 0 to 99% of travel. The time taken will be measured and compared to the original full stroke test recorded at the commissioning stage for each solenoid and combination of solenoids.

A pass or fail will be displayed and the alarm will be activated if enabled. Internal pressure will also be measured and recorded in the datalogger.

The PST can be initiated remotely hardwired, through the network card or locally with the Rotork Bluetooth® Setting Tool *Pro*.

The SI₃ range also provide the facility to undertake a Full Stroke Test (FST) during scheduled planned maintenance. FST is selected in the actuator menu.

Positioning Control

The SI₃ actuators are suitable for positioning control applications and will position a valve or damper from an analogue mA or voltage input signal, digital pulsed or through a range of network cards or the HART interface.

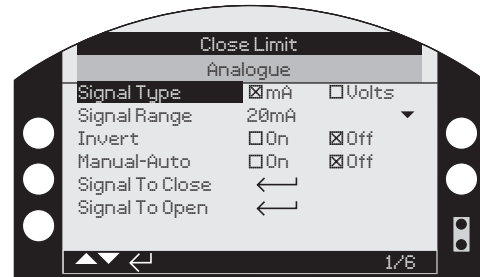

When analogue control is selected independent deadband and hysteresis adjustments are provided in the menu to optimise the control to suit the process conditions. The position against demand profile can also be tailored to suit the specific valve flow characteristics such as linear or equal percentage profile by utilising the Rotork Insight2 software.

With slowmode option selected the actuator will position the valve to a resolution <0.25% and remote position feedback is provided with the option of a 4-20 mA output signal for valve position.

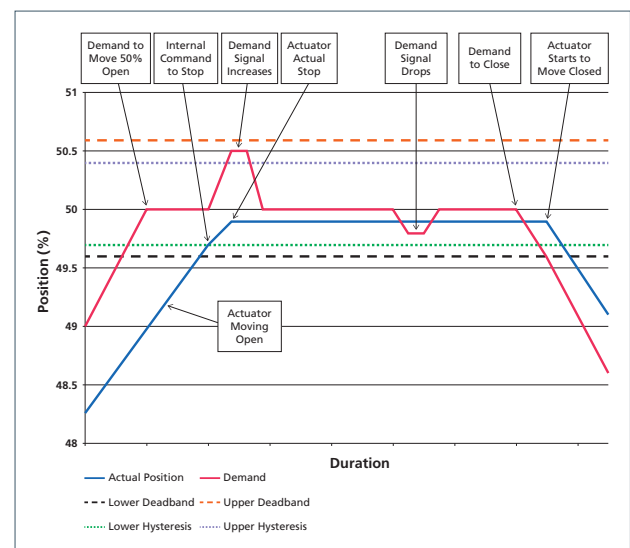
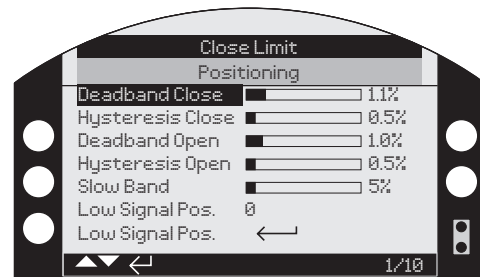

SI₃ Features

Datalogger

The internal datalogger provides data of the actuator, valve and input signals. The datalogger stores the configuration set-up, events, trends, status and alarms with up to 3,000 events held in the actuator memory. The position, hydraulic pressure and temperature are also continuously monitored and stored.

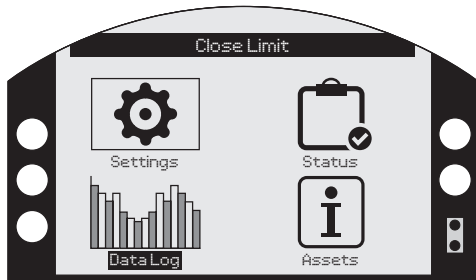

The data can be viewed locally on the dot matrix display and can display pressure and position graphs through to statistical operational data. All data held is secure and can be downloaded using the Rotork Bluetooth® setting tool for viewing on a PC with Rotork Insight2 software.

All configurations and datalogger files are stored in non-volatile EEPROM memory, which means all settings are safe when the power is removed. An internal super capacitor is provided to maintain the real time clock when the actuator is not powered for periods over two weeks should the power supply be disconnected.

The datalogger provides comprehensive data capture and analysis for planned maintenance and troubleshooting issues with the valve and processes, this includes:

- Pressure profiles
- Operational starts profiles
- Operational, vibration and temperature trend logs
- Event logs

Asset Management

Asset management data regarding the actuator and the valve can be stored within the actuator including tag numbers, actuator build data and valve information along with service information. Specific asset management information includes:

- Running time
- Average pressure
- Starts
- Life statistics

To improve asset management and providing reliable data to optimise preventative maintenance, the SI₃ includes configurable service / maintenance alarms. The alarm parameters include:

- Pressure at Open limit
- Pressure at Closed limit
- Starts/hr
- Total starts
- Service intervals

Auxiliary Supply

Auxiliary 24 VDC supply option card is offered for applications where indication relays, sensors, network cards, display, and datalogger are required to be maintained when mains power is not available. This option will also provide a log of valve movement on loss of mains supply. The fail-safe action will be recorded and remote indication will be maintained.

SI₃ Features

Network System Connectivity

With the addition of the appropriate option card, the SI₃ actuator can be incorporated in a number of different network control systems. The SI₃ actuators can be utilised within the Rotork Pakscan control system and all major open fieldbus protocols, including Profibus®, Foundation Fieldbus®, Modbus® and HART®. All control functions, position and status indication would be communicated through the chosen network. When used in a functional safety application the actuator would be supplied with hardware ESD input which will take priority over all other commands.



Modbus®



Actuator Specification

Performance Summary

Standard Torque Range

Torque Output – Spring-Return Clockwise

Model	Hydraulic Direction Torque Output (Nm)			Spring-Return Torque (Nm)		
	BTO	RTO	ETO	BTC	RTC	ETC
SI3-085S-060F/C3	3,261	1,395	1,581	3,820	1,826	2,381
SI3-085C-060F/C3	5,120	1,163	1,186	3,285	1,974	3,778
SI3-085S-070F/C6	4,419	1,968	2,349	5,036	2,448	3,259
SI3-085C-070F/C6	6,939	1,683	1,780	4,327	2,629	5,171
SI3-085S-080F/C7	5,640	2,608	3,264	6,415	3,197	4,388
SI3-085C-080F/C7	8,856	2,276	2,493	5,504	3,400	6,962
SI3-130S-080F/C1	9,255	4,420	5,760	9,496	4,713	6,439
SI3-130C-080F/C1	14,532	3,919	4,427	8,149	5,021	10,217
SI3-130S-090F/C5	10,976	5,146	6,554	12,628	6,371	8,879
SI3-130S-100F/C6	13,849	5,882	6,608	16,955	8,187	10,815
SI3-130C-100F/C6	21,634	4,831	4,889	14,513	8,771	17,036
SI3-161S-100F/C2	18,189	9,506	13,812	16,307	8,506	12,332
SI3-161S-110F/C3	21,880	11,820	17,846	18,998	10,194	15,274
SI3-161C-110F/C3	34,356	11,056	13,982	16,220	10,550	24,237
SI3-161S-125F/C4	28,345	15,344	23,224	24,385	13,094	19,635
SI3-161C-125F/C4	44,506	14,366	18,201	20,818	13,548	31,156

Torque Output – Spring-Return Anti-Clockwise

Model	Spring-Return Torque (Nm)			Hydraulic Direction Torque Output (Nm)		
	BTO	RTCO	ETO	BTC	RTC	ETC
SI3-085S-060F/O3	3,820	1,826	2,381	3,261	1,395	1,581
SI3-085C-060F/O3	6,114	1,666	1,894	2,752	1,526	2,366
SI3-085S-070F/O6	5,036	2,448	3,259	4,420	1,968	2,350
SI3-085C-070F/O6	8,053	2,246	2,593	3,729	2,125	3,550
SI3-085S-080F/O7	6,415	3,197	4,388	5,640	2,608	3,265
SI3-100C-080F/O2	12,007	3,205	3,596	6,324	3,642	6,266
SI3-130S-080F/O1	9,496	4,713	6,439	9,255	4,420	5,760
SI3-130C-080F/O1	15,167	4,356	5,124	7,808	4,667	8,827
SI3-130S-090F/O5	12,628	6,371	8,879	10,976	5,146	6,554
SI3-130S-100F/O6	16,882	8,141	10,736	13,778	5,835	6,530
SI3-130C-100F/O6	27,008	7,451	8,541	11,626	6,409	9,753
SI3-161S-100F/O2	16,357	8,538	12,388	17,875	9,384	13,466
SI3-161S-110F/O3	18,998	10,194	15,274	21,882	11,820	17,848
SI3-161C-110F/O3	30,016	9,583	12,059	18,370	11,984	27,698
SI3-161S-125F/O4	24,385	13,094	19,635	28,344	15,344	23,223
SI3-161C-125F/O4	38,745	12,398	15,624	23,914	15,633	36,294

SI₃-3 actuators can be supplied with additional torque configurations please consult your local Rotork Office

Stroke adjustment: 0 to 90°, ± 5% at each end of travel

Operating Temperature: See Temperature selection code in model code table A: F -30 to +70 °C, H -40 to +70 °C, L -50 to +40 °C

Actuator Specification

Operating Speeds

Model	Hydraulic Direction Stroke Times (secs)			Options for Spring Direction - Stroke Times (secs)										
	Speed 1 (24 VDC)	Speed 2 (VAC)	Speed 3 (VAC)	1	Fixed Orifice					Pressure Compensated Orifice Valve				
					2	3	4	5	6	7	8	9	10	
SI3-085S-060F/*3	48	21	15	0.5	2.4	7	13	20	28	39	51	66	84	
SI3-085C-060F/*3	52	23	16	0.6	2.6	7	14	21	30	42	55	71	90	
SI3-085S-070F/*6	65	29	20	0.7	3.3	9	17	27	38	53	70	90	114	
SI3-085C-070F/*6	70	31	22	0.8	3.6	10	18	29	41	56	75	96	122	
SI3-085S-080F/*7	85	38	26	1.0	4.3	12	23	35	50	69	91	118	148	
SI3-085C-080F/*7	92	40	28	1.0	5	13	24	37	54	74	98	126	159	
SI3-100C-080F/O2	107	47	33	1.2	5	15	28	44	63	86	114	148	186	
SI3-130S-080F/*1	131	58	41	1.5	7	18	35	53	76	105	139	180	227	
SI3-130C-080F/*1	139	61	43	1.6	7	20	37	57	81	112	148	191	242	
SI3-130S-090F/*5	165	73	51	1.9	8	23	44	67	97	133	176	228	287	
SI3-130S-100F/*6	205	90	63	2.3	10	29	54	83	119	165	218	281	355	
SI3-130C-100F/*6	217	96	67	2.5	11	31	57	89	127	175	231	299	377	
SI3-161S-100F/*2	251	110	78	2.9	13	35	66	102	147	202	267	345	436	
SI3-161S-110F/*3	304	134	94	3.5	15	43	80	124	177	244	323	418	527	
SI3-161C-110F/*3	325	143	101	3.7	16	46	86	132	190	261	345	446	564	
SI3-161S-125F/*4	393	173	122	4.5	20	55	104	160	229	316	418	540	682	
SI3-161C-125F/*4	419	184	130	4.8	21	59	111	171	245	337	446	576	728	

* Select C for spring-return Clockwise, O for spring-return Anti-clockwise.

Standard Specifications

Remote Control and Indication

The SI₃ range enables remote control and indication of valves or dampers. The following actuator control and indication options are available to meet the requirements of various site control systems from simple manual push-button control, emergency shutdown (ESD) in functional safety systems through to Distributed Control Systems (DCS) using hardwired switched signals, analogue or digital “bus” network systems.

Control Mode:

Two position – open, close & maintain, partial stroke test and emergency shutdown (ESD).

Positioning control – Analogue 4-20mA input & output of valve position with slowmode solenoid option.

Remote control through optional network card – with hardwired ESD when required.

Hardwired Control (Standard)

Operation	Type	Range	Comments
Open/Close/Maintain & Common	3 x opto-isolated inputs designed for pulsed or maintained contacts	20 - 60 VDC 40 - 120 VAC	Positive switched - actuator derived 24 VDC or externally supplied from the control system. Minimum pulsed duration of 300 ms

ESD circuits to be powered by an external 24V VDC ±10% on fail in position on loss of mains power supply.

Analogue Control (Optional)

Operation	Type	Range	Comments
Positioning Control	1 x opto-isolated input	0 - 5 V 0 - 10 V 4 - 20 mA	Proportional control over the whole or part of the valve stroke. Configurable for open, close or stay put on loss of analogue signal. Resolution: <0.25% of full scale Deadband and Hysteresis are adjustable to optimise control Slowmode option should be selected to provide improved resolution and reduced overshoot

Output: 4-20 or 20-4 mA, powered internally by an isolated 24 VDC supply or external customer supply.

Network Control (Optional)

The SI range is available with the following network interface cards to enable remote control and indication using digital “bus” network systems communication to the Distributed Control Systems (DCS).

Network Type	Comments
Pakscan	An internally mounted <i>Pakscan</i> field unit for remote control and status indication over a fault tolerant two wire serial link. Loop distances of up to 20 km without repeaters and host communications using Modbus protocol. System variables programmable over the Bluetooth data link. For more information please refer to PUB059-030.
Modbus	Modbus modules suitable for single or dual communication highways may be included in the IQ actuator, to provide Fieldbus communication of all the actuator control functions and feedback data. Data is carried on an RS485 data highway and the communications protocol used is Modbus RTU. System variables such as unit address and data baud rate are programmed over the Bluetooth data link. For more information please refer to PUB091-001.
Profibus	Profibus DP single or dual interface module is available to allow the actuator to be integrated into a Profibus network. Full compatibility with EN 50170 is provided and the Profibus network allows full actuator control and feedback of data to the host. For more information please refer to PUB088-001.
Foundation Fieldbus	An IEC 61158-2 compliant Foundation interface module allows the actuator to be connected to a Foundation network. The device has link scheduler capability as well as digital and analogue function block capability. Foundation Fieldbus actuators can communicate directly between themselves without the need of a host supervisory system. For more information please refer to PUB089-001.
HART	HART (Highway Addressable Remote Transducer) is a process control communication protocol. The signal consists of two parts, the analogue 4-20 mA current loop and a superimposed digital signal. Traditionally the 4-20 mA loop is used for control and the superimposed digital signal for feedback, diagnostics and configuration. Configuration and feedback using the HART digital signal can be achieved using the host connected to the actuator to select the parameters required. The majority of the user configurable settings can be made over the HART communication protocol. See PUB092-001 for further details.

Standard Specifications

Remote Indication (Standard)

Operation	Type	Range	Comments
Position, status and alarm indication	4 x configurable volt free latching contacts - S1 to S4. Single pole - single throw (SPST), configurable NO or NC	5 mA to 5 A ¹ 120 VAC 30 VDC	Independently configured using the Rotork Bluetooth Setting Tool to signal one of the following: Valve position: fully open, fully closed or intermediate positions (0-99% open) Status: Valve opening, closing, moving, local -stop, local, remote selected, Temperature trip, Partial Stroke active PST pass / failed test, Full stroke active, FST pass or fail and motor running. Control Alarms: ESD active, manual reset, Lost phase (3 phase only), and manual operation Process alarms: Over pressure tripped at limit or mid travel, valve stalled, Motor thermostat. Actuator alarms: customer 24 VDC supply lost, loss of HMI and Bluetooth General alarm – including all alarms above
Actuator availability / fault indication	Monitor relay configurable change over contact	5 mA to 5 A 120 VAC 30 VDC	The relay will be de-energies when the actuator is unavailable for remote control due to any one or more of the following conditions: Power supply or control supply lost; local control selected; local stop selected; motor thermostat tripped; detected internal failure In fault mode, as above but ignores local/stop selection
Mechanical Limit Switches	Single pole double throw (SPDT)	16 A @ 250 VAC, 0.6 A @ 125 VDC	Standard 2 x SPDT limit switches

Note 1. Maximum total combined current through all four relays not to exceed 8 A

Remote Indication (Optional)

Operation	Type	Range	Comments
Position, status and alarm indication	Up to 8 configurable volt free latching contacts. Single pole – change over (SPCO) ²	5 mA to 5 A ¹ 120 VAC 30 VDC	Independently configurable using the supplied Rotork Bluetooth® Setting Tool <i>Pro</i> as per contacts S1 to S4 above
Analogue position feedback	Current position transmitter - CPT	4-20 mA output proportional to position	Auto range to set limits. Normally internally powered, available suitable for externally 'loop' powered - will default to 4 mA when actuator is powered down.
Analogue pressure feedback	Current pressure transmitter - CTT	4-20 mA output proportional to pressure	Selected in the menu as an alternative to the analogue position feedback. Pressure can be selected as a range of 0% to 120% of rated pressure (4-20 mA).
Auxiliary power supply	Maintains power to the actuator controls on loss of mains	Nominal 24 VDC, 1 A (switching in-rush 8 A max)	Maintains backlit display, CPT analogue indication and bus network communications during actuator power outages. Customer supply is isolated from internal control power for protection
Mechanical Limit Switches	Single pole double throw (SPDT)	16 A @ 250 VAC, 0.6 A @ 125 VDC	4 x SPDT limit switches
Optional Proximity Limit Switches	Normally Open or Normally Close	Operating voltage 5-60 VDC Operating current 4 to 100 mA	2 x P & F - V3 – 2 wire switched output 4 x P & F - V3 – 2 wire switched output
	Single pole double throw (SPDT)	5 A @ 250 VAC and 28 VDC	2 x SPDT Nova V3-N1 switches 4 x SPDT Nova V3-N1 switches

Notes

- Maximum total combined current through the bank of four relays not to exceed 8 A.
- Option - Four additional relays are available to provide up to 8 output contacts

Standard Specifications

Control Features (Standard)

Feature	Comments
Set-up	Simple non-intrusive, interactive set-up procedure using supplied Rotork Bluetooth® Setting Tool <i>Pro</i> with LCD display. Settings include limits, pressure, indication contacts and control options. Settings may be password protected. Setting tools are provided on a 1 for 10 actuators basis, additional setting tools available on request.
Stepping Control	To slow the rate of closing and / or opening over 0 –100% of stroke, The stepping option is selected in the menu and the required stepping control travel, stroke time and number steps are set in the menu. This feature does not operate with loss on power supply, spring-return speed can be adjusted using the hydraulic flow control option.
Fast Remotes	Hardwired switching down to 100 ms pulses for precise positioning.
Slow-Mode	With slow mode solenoid option provided accurate positioning control will be achieved. The slow mode is selectable in the menu and the flow control valve is adjusted to suit the application.
Datalogger	Standard onboard datalogger provides hydraulic pressure, position and starts profiles, operational statistics, events log. Actuator configuration & manufacturing data is also available. Files can be downloaded directly to a PC or to the Rotork Bluetooth® Setting Tool <i>Pro</i> (IS certified) for transfer to a remote PC. Freeware Insight2 for PC is available to download at www.rotork.com Using Insight2; actuators may be configured and analysed over a Bluetooth interface.
Micro-controller	Provides all control function logic, setup programming and allied system requirements. Software is field upgradeable for future enhancements. The micro-controller is widely used in the automotive industry with a long track record and a very reliable history.
Memory	All configured settings are stored in non-volatile EEPROM memory (does not require power).

Certification

Functional Safety

The SI₃-3 range are certified by TUV Rheinland to IEC 61508:2010 for Safety Instrumented Systems, with a Systematic Capability SC-3 and suitable for use in SIL 2 & SIL 3 system. A copy of the certificate is available from Rotork with PFD and SFF data, hardware fault tolerance (HFT) according to Table 6 of IEC 61511-1 should be observed.

Non Hazardous and Hazardous areas Certification

All SI₃ actuator control modules are watertight to IP66/ IP68/NEMA Type 4 & 6. Through the use of non-intrusive commissioning, using the Rotork Bluetooth® Setting Tool *Pro*, covers do not need removing and therefore the hermetic, factory-sealed enclosure protects internal components for life. The terminal compartment is sealed from electrical and

electronic compartments by the Rotork double-seal design, maintaining watertight integrity even during site wiring.

In addition, the Rotork Bluetooth® Setting Tool *Pro* is certified Intrinsically Safe permitting power-on commissioning in hazardous areas.

Actuators are available with the following enclosure types for which the ambient working temperature ranges are stated. Where option temperatures are indicated, changes to some actuator components are required and therefore the temperature requirement must be specified. Hazardous area approvals for other country standards are available; please contact Rotork.

The SI₃ range of actuators are available in accordance with the following standards:

Standard Watertight

Standard	Rating	Standard	Option 1	Option 2	Option 3
BS EN 60529 (1992)	IP66 / IP68 (7m for 72hrs)	-15 to +70 °C (+5 to +158 °F)	-30 to +70°C (22 to +158 °F)	-40 to +70 °C (-40 to +158 °F)	-50 to +40 °C (-58 to +104 °F)
IEC 60529 (1989-11)	IP66 / IP68 (7m for 72hrs)				

Hazardous area

ATEX (European)

Code	Enclosure Code	Standard	Option 1	Option 2	Option 3
ATEX II 2G c	Ex db ① IIB T4	-15 to +70 °C (+5 to +158 °F)	-30 to +70 °C (22 to +158 °F)	-40 to +70 °C (-40 to +158 °F)	-50 to +40 °C (-58 to +104 °F)
ATEX II 2G c	Ex db ① IICT4	-15 to +70 °C (+5 to +158 °F)	-30 to +70 °C (22 to +158 °F)	-40 to +70 °C (-40 to +158 °F)	-50 to +40 °C (-58 to +104 °F)

IEC Ex (International)

Code	Enclosure Code	Standard	Option 1	Option 2	Option 3
IEC Ex	Ex db ① IIB T4	-15 to +70 °C (+5 to +158 °F)	-30 to +70 °C (-22 to +158 °F)	-40 to +70 °C (-40 to +158 °F)	-50 to +40 °C (-58 to +104 °F)
IEC Ex	Ex db ① IIC T4	-15 to +70 °C (+5 to +158 °F)	-30 to +70 °C (-22 to +158 °F)	-40 to +70 °C (-40 to +158 °F)	-50 to +40 °C (-58 to +104 °F)

cCSAus – (USA) Pending

Class	Division	Groups	Standard	Option 1	Option 2	Option 3
I	1	B & C / D	-15 to +70 °C (+5 to +158 °F)	-30 to +70 °C (-22 to +158 °F)	-40 to +70 °C (-40 to +158 °F)	
Class / Zone	Enclosure Code		Standard	Option 1	Option 2	Option 3
Class 1 / Zone 1	AEx d ① IIB T4		-15 to +70 °C (+5 to +158 °F)	-30 to +70 °C (-22 to +158 °F)	-40 to +70 °C (-40 to +158 °F)	-50 to +40 °C (-58 to +104 °F)
Class 1 / Zone 1	AEx d ① IIC T4		-15 to +70 °C (+5 to +158 °F)	-30 to +70 °C (-22 to +158 °F)	-40 to +70 °C (-40 to +158 °F)	-50 to +40 °C (-58 to +104 °F)

Certification

CSA (Canadian) Pending

Class	Division	Groups	Standard	Option 1	Option 2	Option 3
I	1	B & C / D	-15 to +70 °C (+5 to +158 °F)	-30 to +70 °C (-22 to +158 °F)	-40 to +70 °C (-40 to +158 °F)	-50 to +40 °C (-58 to +104 °F)
Directive Code	Enclosure Code		Standard	Option 1	Option 2	Option 3
	Ex d ① IIB T4		-15 to +70 °C (+5 to +158 °F)	-30 to +70 °C (22 to +158 °F)	-40 to +70 °C (-40 to +158 °F)	-50 to +40 °C (-58 to +104 °F)
x	Ex d ① IIC T4		-15 to +70 °C (+5 to +158 °F)	-30 to +70 °C (22 to +158 °F)	-40 to +70 °C (-40 to +158 °F)	-50 to +40 °C (-58 to +104 °F)

EAC (Russia) Pending

Directive Code	Enclosure Code	Standard	Option 1	Option 2	Option 3
TRTS	Ex d ① IIB T4	-15 to +70 °C (+5 to +158 °F)	-30 to +70 °C (22 to +158 °F)	-40 to +70 °C (-40 to +158 °F)	-50 to +40 °C (-58 to +104 °F)
TRTS	Ex d ① IICT4	-15 to +70 °C (+5 to +158 °F)	-30 to +70 °C (22 to +158 °F)	-40 to +70 °C (-40 to +158 °F)	-50 to +40 °C (-58 to +104 °F)

① "e" added on versions with increased safety terminal enclosure

Bluetooth Setting Tool Pro

Region	Directive/Standard	Rating	Temperature
Europe	ATEX II 1 G	Ex ia IIC T4	-30 to +50 °C (-22 to +122 °F)
International	IECEX	Ex ia IIC T4	
United States	FM3610	Intrinsically Safe - Class I, Division 1 Groups A, B, C & D: T4	
Canada	CSA C22.2 No.157-92	Intrinsically Safe - Class I, Division 1 Groups A, B, C & D: T4	

Regulatory Standards

Compliance with the following European Union Directives permits the SI₃ range of actuators to be CE marked under the provision of the Machinery Directive.

Directive	Applicable to	Reference
Electro-magnetic Compatibility (EMC)	Immunity to/emissions of electromagnetic energy	2004/108/EC
Low Voltage (LVD)	Electrical Safety	2006/95/EC
Machinery*	Product Safety	Actuators follow the provision of the Machinery Directive 2006/42/EC. The SI ₃ must not be put into service until the equipment into which it is being incorporated has been declared to be in conformity with the provisions of the European Community Machinery Directive 2006/42/EC.
Pressure Equipment (PED)	European Union	97/23/EC
Waste Electrical Equipment (WEE)	Exempt under the scope of the directive	
Federal Communications Commission	Bluetooth modules - actuator and Rotork Bluetooth® Setting Tool Pro.	Contains FCC certified transmitter module. Refer to PUB002-039 for FCC ID.

Note

*Actuators are not classified as machines within the scope of the machinery directive. Contact Rotork for a copy of our Declaration of Conformity and Incorporation

Certification

Standard Specification

Materials

Component	Material	Grade	Coating
Actuator	Carbon Steel Ductile Iron	See GH data sheet for full details	Painted
Control module	Aluminium	BS EN 1706 AC-42000- (LM25) BS EN 1706 AC-42100- (L99) ASTM B5 GRADE A360	Painted
Hydraulic manifold block	Aluminium (Standard) Stainless Steel (Optional)	BS EN 573-1 6082 T6 (3.2315) 316	Plasma-Electrolytic Oxidisation
Oil Reservoir	Carbon Steel	BS EN 10025, S275JR	Painted
Fasteners	Stainless Steel	A4-80 (316)	N/A
Fittings & Tubing	Stainless Steel	316	N/A

Hydraulic Seals & Oil

Temperature	Control Module Seals	Actuator	Hydraulic fluid
-15 to +70 °C (+5 to +158 °F)	Nitrile – Optional Viton	Nitrile – Optional Viton	Mineral Fluid CL 32 (cSt 32)
-30 to +70 °C (-22 to +158 °F)	Nitrile	Nitrile	Synthetic Fluid CO32 (cSt 32)
-40 to +70 °C (-40 to +158 °F)	HNBR	Flourosilicone	Synthetic Ester based Low temperature fluid (Food Grade) 3 cSt
-50 to +40 °C (-58 to +104 °F)	HNBR	Flourosilicone	Synthetic Ester based Low temperature fluid (Food Grade) 3 cSt

For northern hemisphere application synthetic fluid is recommended

Components

Internal Power Supplies

Type	Internal Power Supplies
AC	Transformer producing control circuits, option card supplies and supply for 24 VDC actuator fed remote control. Fuse protected.
DC	DC-DC converter isolates the DC actuator supply from internal supplies for control and 24 VDC supply for actuator fed remote control. Fuse protected. Incorporates sleep circuit for power reduction when used on solar powered derived DC supplies.

Motors

SI₃ actuators utilise purpose designed motors that are integral to the actuator. As such, these motors do not fall within the scope of IEC 60034 or MG1, however they do meet the applicable requirements, where appropriate, of motor design for actuator operation.

Voltage	Motor
Single- & Three-Phase	Class F insulated, single & three-phase squirrel cage motor incorporating thermostat protection. Low inertia design.
DC	Class F insulated, DC motor and incorporating thermostat protection.

Manual Override

On loss of power or control network, SI₃ actuators are available with the option of a hand pump manual override. The manual override consists of a hydraulic hand pump and a lockable selector valve, the manual selector valve is normally locked in the electrical operating position for normal actuator operation. When the power supply or control signal is not available the pipeline valve can be operated manually by removing the lock on the manual override selector valve and rotating the selector valve through 90° to the manual position.

The hand pump can be operated to move the actuator in the hydraulic direction. Selecting electrical operation position on the manual selector valve will return the actuator in the spring direction.

Care must be taken when using the manual override, in the manual position the actuator will not be part of a Safety Instrumented System (SIS) and will not respond to an ESD signal. The manual selector valve will detect when manual mode has been selected and prevent electrical operation until the valve has been returned to the normal electrical control

position. The local mechanical position indicator will show the position of the valve.

Should power be reinstated while the actuator is in manual mode the actuator will display a manual alarm.



Electrical

Cable Entries

The SI₃ Control module is machined with conduit/cable entries as indicated below. Alternative adapters are available.

Type	Adapter Material	Thread
Standard	N/A	4 x M25 x 1.5 P
Option 1	Nickel Plated Brass	4 x M20 x 1.5 P 4 x M32 x 1.5 P 4 x 1/2" NPT 4 x 3/4" NPT
Option 2	Stainless Steel (316)	4 x 1" NPT 4 x 1 1/4" NPT

SI actuators are dispatched with transit plugs fitted into the conduit entries. It is the responsibility of the installer to ensure the appropriate cable/conduit adapters, cable glands and/or blanking plugs are fitted in order to maintain hazardous area certification and ingress protection levels. Certified adapters and blanking plugs are available as optional extras.

Terminals

The terminal compartment for SI₃ actuators takes the form of a separately sealed compartment containing segregated metric thread M5 power and M4 control terminals. Terminal screws and washers are supplied with the actuator. Terminals are designed to accept ring tag crimped field wiring conductors up to 16 mm² for power and 4 mm² for control/ indication. Each actuator is dispatched with the applicable installation and maintenance manual, actuator wiring diagram and remote control connection schematic.

Wiring

SI₃ actuators utilise jig built wiring harnesses of individually numbered, tropical grade PVC insulated, stranded conductors. All internal control connections to the printed circuit boards use unique plugs and sockets.

Electrical

Power Supplies

SI₃ actuators are suitable for operation with the following power supplies:

Voltage Type	Voltage
Single-phase	110, 120 & 230 V - 50 Hz 110, 120 & 230 V - 60 Hz
Three-phase	380, 400, 415 & 440 V - 50 Hz 380, 400, 415, 440, 480 & 575 V - 60 Hz
DC	24 V

Voltage tolerance	±10%	Applies for rated torque performance; duty cycle and speed is not guaranteed
Frequency tolerance	±5%	Applies for rated torque performance; duty cycle and speed is not guaranteed
Maximum starting volt drop	-15%	Actuators capable of starting and running up to speed
Non-standard tolerances	Larger volt drops / frequency variations than those quoted can be catered for but may affect actuator selection & sizing. Contact Rotork.	
Uninterruptible power supply systems	For AC systems, UPS systems should conform to recognised supply standards such as EN60160 in respect of waveform, spikes, harmonics etc. The tolerances above should not be exceeded.	

Power Consumption – Mains power

Voltage	Power Consumption				
	Hydraulic direction		Hold position		Spring-return direction
	Power	Inrush current*	Fail Safe (FS) on loss of mains power**	Fail in Position (FIP) on loss of mains power**	
Single / Dual SOV					
24 VDC	230 W	12 A	7 W / 10.5 W	3.5 W	3.5 W
Single-phase 110 /120 VAC	1.12 kW	67 A	7 W / 10.5 W	3.5 W	3.5 W
Single-phase 230 VAC	1.06 kW	28 A	7 W / 10.5 W	3.5 W	3.5 W
Three-phase 380 to 575 VAC	0.96 kW	16 A	7 W / 10.5 W	3.5 W	3.5 W

*Inrush current for 300 mS

** select either Fail-safe (FS) or Fail in Position (FIP) in model code

Power Consumption – ESD Input Circuit

ESD & Solenoid (SOV) configurations	Power Consumption			
	Single SOV		Dual SOV	
	ESD 1	ESD 2	ESD 1	ESD 2
Standard (Fail safe) Single SOV	0.17 W	N/A	0.17 W	N/A
Standard (Fail-Safe) Dual SOV	0.17 W	< 0.02 W	0.17 W	< 0.02 W
Standard (Fail-Safe) Independent SOV's	0.17 W	< 0.02 W	0.17 W	< 0.02 W
Hardwired (FIP) Single SOV*	4.35 W	N/A	7.85 W	N/A
Hardwired (FIP) Dual SOV*	0.17 W	4.35 W	0.17 W	7.85 W
Hardwired (FIP) Independent SOV's*	N/A	N/A	3.5 W	4.35 W

Hardwired - Fail in Position on loss of power supply - Solenoids powered from the ESD input circuit

Actuator Dimensions

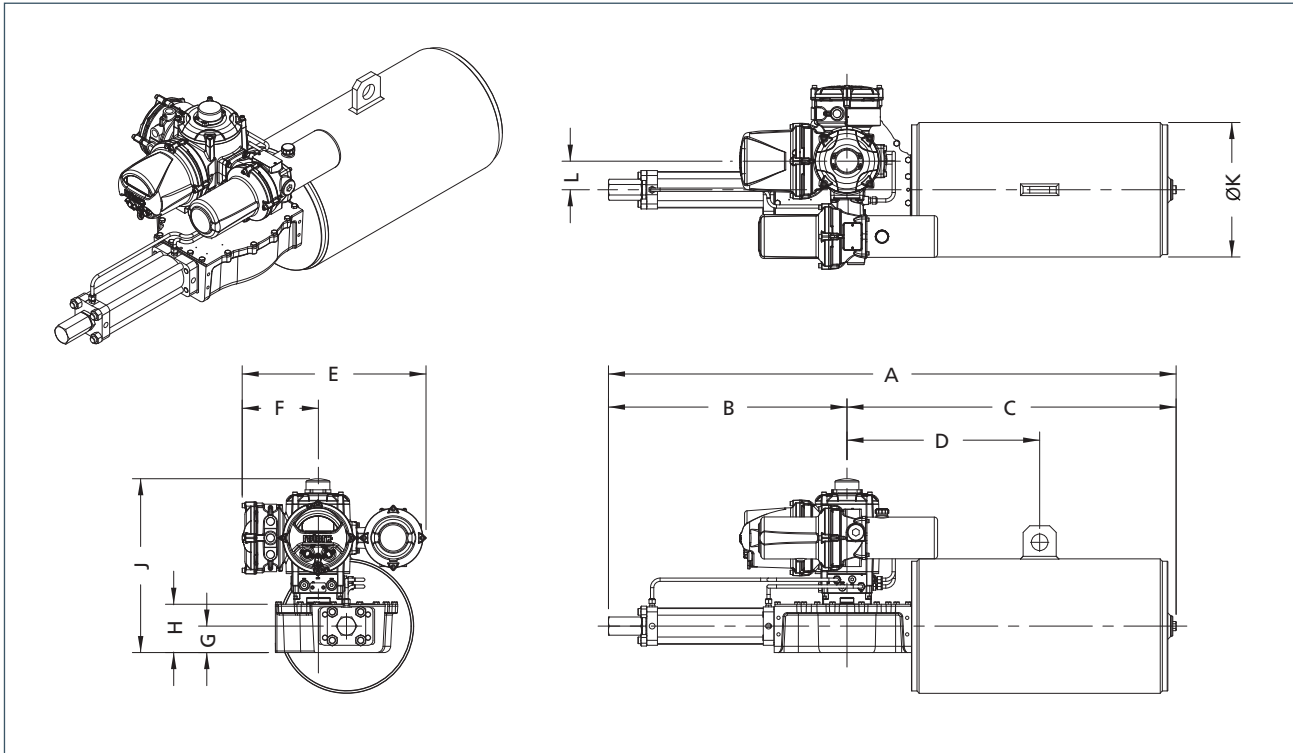

Actuator	Actuator Dimensions (mm)											Weight (kg)
Size	A	B	C	D	E	F	G	H	J	K	L	
SI ₃ -085 ¹ -060 ² / ₃₃	1599	717	882	519	556	229	80	146	522	324	85	279
SI ₃ -085 ¹ -070 ² / ₃₆	1604	722	882	496	556	229	80	146	522	324	85	307
SI ₃ -085 ¹ -080 ² / ₃₇	1703	717	986	576	556	229	80	146	522	406	85	365
SI ₃ -100C-070 ² /O2	1985	900	1085	658	556	229	93	177	549	406	100	418
SI ₃ -130 ¹ -080 ² / ₃₁	2255	980	1275	689	556	229	113	200	576	457	130	587
SI ₃ -130 ¹ -090 ² / ₃₅	2262	981	1281	760	556	229	113	200	576	508	130	817
SI ₃ -130 ¹ -100 ² / ₃₆	2262	981	1281	760	556	229	113	200	576	508	130	870
SI ₃ -161 ¹ -100 ² / ₃₂	3207	1173	2034	1181	556	229	150	232	608	610	160	1330
SI ₃ -161 ¹ -110 ² / ₃₃	3003	1139	1864	1097	556	229	150	232	608	610	160	1293
SI ₃ -161 ¹ -125 ² / ₃₄	3023	1159	1864	1097	556	229	150	232	608	610	160	1460

Notes

1. Select S for Symmetric, C for Canted yoke
2. Temperature selection F, H, L or G
3. Select C for spring-return Clockwise, O for spring-return Anti-clockwise.

Actuator Mounting

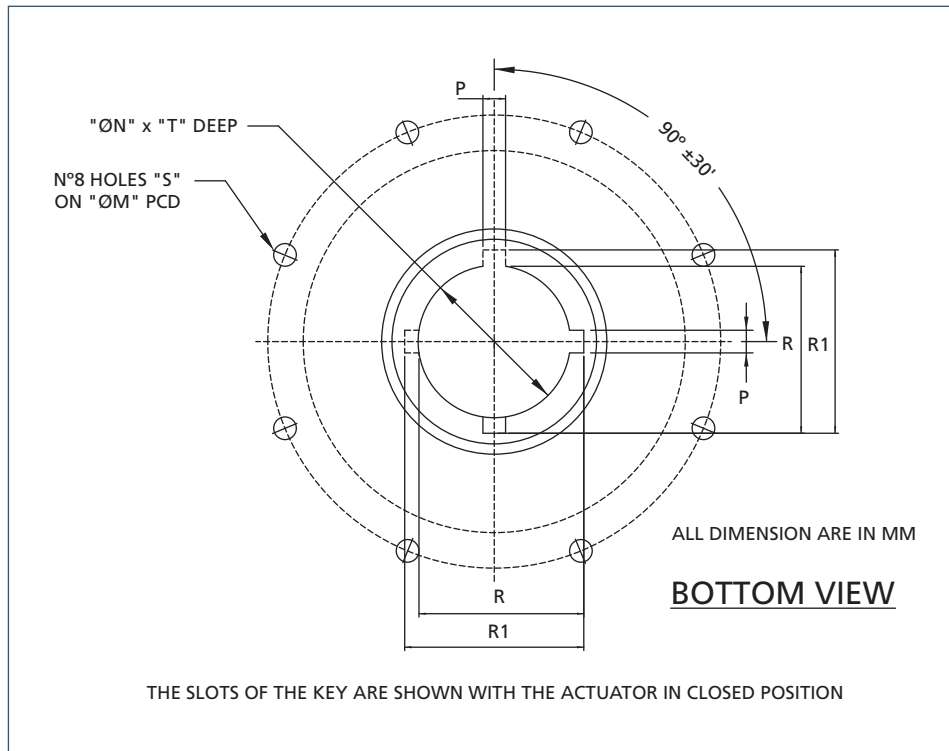

Actuator	Actuator Mounting (mm)											
Size	ISO 5211 Flange type	M	N		P		R		R1		S	T
SI ₃ -085	F25	254	65	+0.25 +0.15	18	+0.12 +0.05	69.4	+0.2 +0			M16x2 Deep 18	130
SI ₃ -100	F25	254	75	+0.25 +0.15	20	+0.149 +0.065	79.9	+0.2 +0			M16 x 2 Deep 25	140
SI ₃ -130	F30	298	110	+0.25 +0.15	28	+0.149 +0.065			122.8	+0.1 +0	M20 x 2.5 Deep 22	175
SI ₃ - 161	F35	356	150	+0.25 +0.15	40	+0.18 +0.08			168.8	+0.2 +0	M30 x 3.5 Deep 39	280

Model Code

Actuator Selection **SI₃-085S-060F/C3-1 A 0 - 0 1 1 - 0 0 1 0 - B A - 0 1 A**

BASE ACTUATOR

Table A Actuator size _____

Table B Power supply _____

Table C Failure Mode _____

ACTUATOR MANIFOLD

Table D Solenoid Valve options _____

Table E Manual Override _____

Table F Spring return stroke speed _____

ELECTRICAL/ CONTROL OPTIONS

Table G Internal limit switches _____

Table H ESD Input options _____

Table J Network cards _____

Table K Additional option cards _____

GENERAL OPTIONS

Table L Certification _____

Table M Cable Entries _____

MECHANICAL OPTIONS

Table N Position Indication _____

Table P Mounting Orientation _____

Table Q Accessories _____



Model Code

Table A – Actuator Size

Model	Description (Size CW)	Hydraulic stroke speed (sec)		
		1	2	3
SI ₃ -085S-060 ¹ /23 ³	End of Spring torque 2,381 Nm	48	21	15
SI ₃ -085C-060 ¹ /23 ³	End of Spring torque 3,778 Nm	52	23	16
SI ₃ -085S-070 ¹ /26 ³	End of Spring torque 3,259 Nm	65	29	20
SI ₃ -085C-070 ¹ /26 ³	End of Spring torque 5,171 Nm	70	31	22
SI ₃ -085S-080 ¹ /27 ³	End of Spring torque 4,388 Nm	85	38	26
SI ₃ -085C-080 ¹ /C7 ³	End of Spring torque 6,962 Nm	92	40	28
SI ₃ -100C-080 ¹ /O2 ³	End of hydraulic torque 6,266 Nm	107	47	33
SI ₃ -130S-080 ¹ /21 ³	End of Spring torque 6,439 Nm	131	58	41
SI ₃ -130C-080 ¹ /21 ³	End of Spring torque 10,217 Nm	139	61	43
SI ₃ -130S-090 ¹ /25 ³	End of Spring torque 8,879 Nm	165	73	51
SI ₃ -130S-100 ¹ /26 ³	End of Spring torque 10,815 Nm	205	90	63
SI ₃ -130C-100 ¹ /26 ³	End of Spring torque 17,036 Nm	217	96	67
SI ₃ -161S-100 ¹ /22 ³	End of Spring torque 12,332 Nm	251	110	78
SI ₃ -161S-110 ¹ /23 ³	End of Spring torque 15,274 Nm	304	134	94
SI ₃ -161C-110 ¹ /23 ³	End of Spring torque 24,237 Nm	325	143	101
SI ₃ -161S-125 ¹ /24 ³	End of Spring torque 19,635 Nm	393	173	122
SI ₃ -161C-125 ¹ /24 ³	End of Spring torque 31,156 Nm	419	184	130

Notes

- Temperature selection F -30 to +70 °C
H -40 to +70 °C
L -50 to +40 °C
G – Viton seals -15 to 70 °C
- Select C for spring-return Clockwise, O for spring-return Anti-clockwise.
- Hydraulic stroke speed select 1 - 24 VDC or Speed 2 or 3 – Single- or Three-Phase VAC

Table B – Power Supply / Frequency

Code	Description
A	24 VDC 50/60 Hz
B	110/120 VAC 50/60 Hz (single-phase)
C	220/230 VAC 50/60 Hz (single-phase)
D	380 VAC 50/60 Hz (three-phase)
E	400 VAC 50/60 Hz (three-phase)
F	415 VAC 50/60 Hz (three-phase)
G	440 VAC 50/60 Hz (three-phase)
H	480 VAC 50/60 Hz (three-phase)
J	575 VAC 50/60 Hz (three-phase)

Voltage ±10%, Frequency ± 5%

Table C – Failure Mode

Code	Description
0	Fail-Safe in direction of the spring on loss of power supply or ESD
1	Fail in Position (lock hydraulics) on loss of power supply, Fail Safe on loss of ESD signal*

*When ESD is selected

Model Code

Options

Table D – Solenoid Valve

Code	Description
0	Single Internal Close /ESD Solenoid
1	Dual Internal Solenoid Close / ESD Solenoids
2	Slowmode Solenoid - Modulating Duty

Table E – Manual Override

Code	Description
0	No Manual Override
1	Standard Hand Pump
2	316 Stainless Steel Hand Pump

Table F – Spring-Return Stroke Speed

Code	Description									
	SI-3/ 085*- 060/*3	SI-3/ 085*- 070/*6	SI-3/ 085*- 080/*7	SI-3/ 100C- 080/O2	SI-3/ 130*- 080/*1	SI-3/ 130*- 090/*5	SI-3/ 130*- 100/*6	SI-3/ 161*- 100/*2	SI-3/ 161*- 110/*3	SI-3/ 161*- 125/*4
0	0.5	0.7	1	1.2	1.5	1.9	2.3	2.9	3.5	4.5
1	2.4	3.3	4.3	5.4	7	8	10	13	15	20
2	7	9	12	15	18	23	29	35	43	55
3	13	17	23	28	35	44	54	66	80	104
4	20	27	35	44	53	67	83	102	124	160
5	28	38	50	63	76	97	119	147	177	229
6	39	53	69	86	105	133	165	202	244	316
7	51	70	91	114	139	176	218	267	323	418
8	66	90	118	148	180	228	281	345	418	540
9	84	114	148	186	227	287	355	436	527	682

* Ex d IIC certified actuators, maximum paint thickness is 200 microns, minimum temperature -20 °C. Four cable entries adaptors

Table G – Internal Limit Switch

Code	Description
0	2 x SPDT Limit Switches
1	4 x SPDT Limit Switches
2	2 x P&F Proximity Switches
3	4 x P&F Proximity Switches
4	2 x SPDT PROX V3-N1 Switches
5	4 x SPDT PROX V3-N1 Switches

Table H – ESD Input Cards

Code	Description
0	Std Single ESD inputs (for Fail-safe mode table C)
1	Std Two Independent ESD inputs (for Fail-safe mode table C)
2	Std Two Dual ESD inputs (for Fail-safe mode table C)
3	Hardwired Single ESD input (for Fail in position mode table C)
4	Hardwired two Independent ESD inputs (for Fail in position mode table C)
5	Hardwired two Dual ESD inputs (for Fail in position mode table C)
6	No ESD input (Fail in position only)

Table J – Network Cards

Code	Description
0	No Network card
1	<i>Pakscan</i>
2	Modbus Single channel
3	Modbus Dual channel
4	Profibus Single channel
5	Profibus Dual channel
6	Foundation Fieldbus
7	HART

Table K – Other Cards (Multiple-options)

Code	Description
0	No additional options card
1	Remote CPT Position or pressure Indication
2	Folomatic & CPT, Positioning Control & Indication
3	Auxiliary 24 VDC Power supply
4	Relay contact S5-S8 - 4 additional changeover relays, fully configurable

Model Code

Table L – Certification

Code	Description
A	WT – Watertight IP66/67
B	ATEX - IIB
C	ATEX - IIC
D	IECEX - IIB
E	IECEX - IIC
F	CSAUS - Group C
G	CSAUS - Group B
H	CSAC - Group C
J	CSAC - Group B
K	TR TS – IIB (Russia)
L	TR TS – IIC (Russia)
M	INMETRO – IIB (Brazil)
N	INMETRO – IIC (Brazil)

Table M – Cable Entries

Code	Description
A	Std 4 x M25 x 1.5P
B	M20 x 1.5P - Nickel plated Adaptors
C	M20 x 1.5P - Stainless Steel Adaptors
D	M32 - Nickel Plated Adaptors
E	M32 - Stainless Steel Adaptors
F	1/2" NPT - Nickel Plated Adaptors
G	1/2" NPT - Stainless Steel Adaptors
H	3/4" NPT - Nickel Plated Adaptors
J	3/4" NPT - Stainless Steel Adaptors
K	1" NPT - Nickel Plated Adaptors
L	1" NPT - Stainless Steel Adaptors
M	1 1/4" NPT - Nickel Plated Adaptors
N	1 1/4" NPT - Stainless Steel Adaptors

Table N – Position Indication

Code	Description
0	No Position Indicator
1	Standard Position Indicator
2	Stainless steel Position Indicator

Table P – Mounting Orientation

Code	Description		
	Valve Stem	Pipeline	Actuator Cylinder
1	Vertical	Horizontal	Parallel to Pipeline
2	Vertical	Horizontal	Perpendicular to Pipeline
3	Horizontal	Horizontal	Parallel to Pipeline
4	Horizontal	Horizontal	Perpendicular to Pipeline
5	Horizontal	Vertical	Perpendicular to Pipeline
6	Horizontal	Vertical	Parallel to Pipeline

Table Q – Accessories

Code	Description
A	Ex Cable Entry Plugs - Nickel Plated
B	Ex Cable Entry Plugs - Stainless Steel
C	SI ₃ -3 Power Module with Local Switchbox
D	Window Protector
E	Vandal Proof Cover
F	Solar Shield
G	Coastal - Std Colour 180 microns
H	Offshore - Std Colour 350 microns
J	Customer Specific Paint Specification
K	Non-Standard Top Coat Colour Change
L	Ex e Terminal Enclosure

A full listing of the Rotork sales and service network is available on our website.

www.rotork.com

Corporate Headquarters
Rotork plc

tel +44 (0)1225 733200
email mail@rotork.com

rotork®

Electric Actuators and Control Systems
Fluid Power Actuators and Control Systems
Gearboxes and Gear Operators
Precision Control and Indication
Projects, Services and Retrofit