

INDUSTRY LEADING FLOW CONTROL NEWS FROM THE WORLD OF ROTORK

rotalk⁴²

P⁴ Pakscan™
Superior Plant Control

**SUPERFAST SCAN
15 MBIT/SECOND**



CONTRACT NEWS

Rotork actuators support the environmental improvement programme at Aberthaw power station [p12](#)

COMPANY NEWS

Mastergear joins the Rotork Group [p20](#)

PRODUCT NEWS

Rotork Pakscan P4 introduces flexible ultra-fast network control for valve actuators [p4](#)

Rotork introduces a revolutionary wireless valve monitoring concept [p11](#)

Rotork ELB Electronic Line Break combines pipeline pressure monitoring with intelligent valve control [p16](#)

Rotork introduces IQTF actuators designed for choke and control valve applications [p17](#)

rotork®

Keeping the World Flowing

CONTENTS

INDUSTRY LEADING **FLOW CONTROL NEWS** FROM THE WORLD OF **ROTORK**

CONTRACT NEWS

- page 3**
Rotork Client Support Programme delivers smart maintenance at VTTI Vasiliko (VTTV) oil terminal
- page 6**
Gearbox packages ordered
- page 6**
Chinese pipelines select Skilmatic electro-hydraulic valve actuators for remote operated failsafe duty
- page 7**
Rotork actuators perform vital fire safety duty on the Istanbul metro
- page 7**
Rotork control valve actuation passes the glass making test
- page 9**
Efficient solution and local support secures contract
- page 9**
Valvekits' largest spool kit, built on the highest quality foundations
- page 10**
Rotork Midland assists Drax with Europe's largest decarbonisation project
- page 10**
Large Soldo order for Egyptian power generation industry
- page 12**
Rotork actuators support the environmental improvement programme at Aberthaw power station
- page 13**
Rotork Japan provides the intelligent actuation solution for the world's first seven-way control valve
- page 14**
EH actuators provide safety shut-down duties for the Korean gas corporation
- page 15**
Scottish water selects Rotork for new valve actuation framework contract

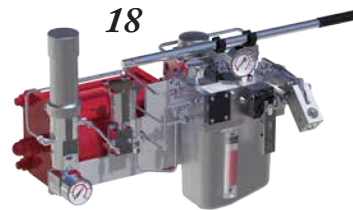

PRODUCT NEWS

- page 4/5**
Pakscan P4 introduces flexible ultra-fast network control for valve actuators
 - page 11**
Rotork introduces a revolutionary wireless valve monitoring concept
 - page 11**
Innovative gearbox with SafeOperator flexible extension enables critical subsea valve operation
 - page 16**
Rotork ELB electronic line break combines pipeline pressure monitoring with intelligent valve control
 - page 17**
Compact explosionproof part-turn electric valve actuator extends the Rotork range
 - page 17**
IQTF intelligent choke valve actuator
 - page 18**
Pressure Safe line break detection
 - page 18**
The SI electro-hydraulic 3rd generation failsafe actuator
 - page 19**
Featured products from Bifold
- ## APPLICATION NEWS
- page 8**
Rotork Schischek simplifies petrochemical sampling and analysis
- ## APPOINTMENTS
- page 20**
New Divisional Sales Director for Rotork Fluid Systems and New Business Development Director for Rotork Instruments



EDITOR'S NOTE

In this edition of Rotalk we highlight the very exciting new control and instrumentation products that we have brought to the market. The Pakscan P4 digital control system builds on 30 years of experience in the field to introduce a new Master Station with advanced features including an ultra-fast Plus Network, comprehensive datalogging, asset management, economical installation and minimum cost of ownership. Continuing the asset management theme, Rotork introduces a revolutionary concept for

wireless valve monitoring and diagnostics. This innovative solution transmits real-time position indication to the control room and enables predictive maintenance, increased safety and increased productivity. Safety is also at the heart of the Rotork ELB Electronic Line Break, a robust self-contained instrument that combines oil and gas pipeline pressure monitoring with intelligent valve control to initiate automatic emergency procedures based on user-defined parameters.

I hope that this gives you an appetite to read on; in the following pages you will also find some interesting application stories involving many of our products. ■

Carlos Elvira
Rotork Group Sales and Marketing Director

ROTORK CLIENT SUPPORT PROGRAMME DELIVERS SMART MAINTENANCE AT VTTI VASILIKO (VTTV) OIL TERMINAL

VTTI B.V., the worldwide independent provider of energy storage, has awarded a Client Support Programme (CSP) contract to Rotork for the maintenance of critical valve actuation assets at the VTTV Oil Storage Terminal in Cyprus.



APPROXIMATELY 400 ROTORK IQ3 actuators controlled by Rotork's *Pakscan* 2-wire digital networks that manage the flow of media throughout the terminal have been covered on the 'tailor-made' CSP contract. The programme exploits the functionality of intelligent IQ3 technology with remote diagnostics and monitoring via dataloggers, enabling preventative maintenance to be organised with little or no interruption to plant operations.

The Rotork CSP involves regularly monitoring the current health and

operable status of every actuator, keeping a full history of all activities performed and any parts used since the previous report.

The information is analysed to provide a breakdown of critical, medium and low priority scheduled work and any corresponding unexpected work activities. Analysis also provides trending of actuator availability and reliability against agreed target costs and historical operating data as compared to agreed key performance indicators.

Ongoing technical support further contributes to increased availability, reliability and improved performance.

The local support of Rotork's Cyprus office assisted the original commissioning of the Rotork equipment at VTT Vasiliko Ltd. and now strengthens the asset management and maintenance functions provided by the CSP. ■



A Rotork Client Support Programme (CSP) maintains critical valve actuation assets at the VTTV Oil Storage Terminal in Cyprus.

PAKSCAN P4 INTRODUCES FLEXIBLE ULTRA-FAST NETWORK CONTROL FOR VALVE ACTUATORS

Rotork's Pakscan product portfolio is well established as the market-leading digital network control system for the valve actuation environment. Around the world more than 150,000 field units are connected to Pakscan networks, delivering robust and reliable plant monitoring and control in all industry sectors. The Ultra-fast network updates at communication speeds of up to 15 Mbit/second.



The large touch screen display provides an easy to use, multilingual, user interface providing quick device setup, interrogation and issue resolution.

BUILDING ON THIRTY YEARS OF experience in the field, *Pakscan P4* now introduces a Master Station with a host of advanced new features.

Intuitive user interface

The large touch screen display provides an easy to use, multilingual, user interface providing quick device setup, interrogation and issue resolution. NAMUR standard diagnostic icons and colouring are used for easy recognition of status and alarms.

Ease of navigation around the screens is enhanced by having identical screens for both the in-built web pages and the integral touch screen, each using the same menu structure. A dedicated service Ethernet port maintains Local Area Network (LAN) separation between configuration or monitoring systems and the systems for controlling the process.

Field networks open to third-party devices

The P4 Master Station has advanced field network option capabilities including a new ultra-fast Plus Network and a Modbus network - enabling connection to third-party Modbus® field devices. Further options provide compatibility and legacy support for existing *Pakscan* wired (Classic) and wireless networks.

The fastest dedicated actuator control network

The ultra-fast Plus network operates at communication speeds of up to **15 Mbit/second** using the highly noise immune SHDSL telecoms protocol. Each Plus network can connect up to **300 field devices** with a distance between each device of up to 5 km, resulting in network lengths which can extend over hundreds of kilometres. The ultra-fast, full-duplex, network enables full modulating positional control of process valves.

P⁴ Pakscan™



High Availability Seamless Redundancy

Priority is given to process data and the built-in High Availability Seamless Redundancy (HSR) ensures instant isolation of any loop fault, without loss of data, allowing continued operation of the plant if a fault occurs. Along with single and dual configurations, the P4 Master Station can be supplied in a hot standby configuration where all interfaces are duplicated, providing the highest level of availability.

Up to four field networks on one Master Station

The modular design enables one P4 Master Station to supervise up to four networks – any combination of Plus, Classic, Wireless and Modbus – incorporating up to 300 field units including third-party devices such as mixers, pumps and transmitters.

Multiple host connectivity

With the ability to connect to multiple hosts the P4 Master Station has a fully pre-configured database providing easy integration with proven communications to all major DCS and PLC suppliers via the Modbus® TCP/ RTU protocol. The touch screen display also allows stand-alone operation in the event of unavailability of the host.

Efficient, low cost of installation and ownership

Pakscan P4 is designed for economical installation and minimum cost of ownership. The single twisted pair cable or wireless network reduces installation engineering effort and associated costs and further economy is enabled by long wired loop network lengths without external repeaters or network biasing and termination. Fast installation and commissioning without specialist software reduces downtime and contributes to improved productivity.

Asset management and datalogging

Swift access to plentiful device data optimises the scope for predictive maintenance and asset management, at the DCS/ PLC, the asset management system or at the Master Station. Available data includes operating history, status, diagnostics and alarm logs. Using the Plus network, the actuator datalogger can be extracted, with no detrimental effects on the speed of process data, and viewed using Insight2 software, enabling valve torque profiles to be analysed.

Existing Pakscan systems upgradeable to P4

The P4 Master Station in conjunction with the a Classic network is compatible with the Classic IIE and P3 wired networks for field and host connectivity and can replace existing Master Stations without further network or device changes. To fully benefit from the P4 advantages, existing Pakscan Classic networks can be upgraded to the Plus network without changing the existing cable; a change of field network card, loom and a minor wiring change at the actuator and Master Station is all it takes.

Backed by Rotork global support

Rotork and third party actuation products are supported by Pakscan P4, which itself is fully supported with documentation, on-site or in-house training and Rotork's global network of trained service engineers. ■

GEARBOX PACKAGES ORDERED

Rotork Houston recently won an order for gearbox packages comprising 242 Series gearboxes with limit switchboxes and custom made Rotork Valvekits mounting kits.

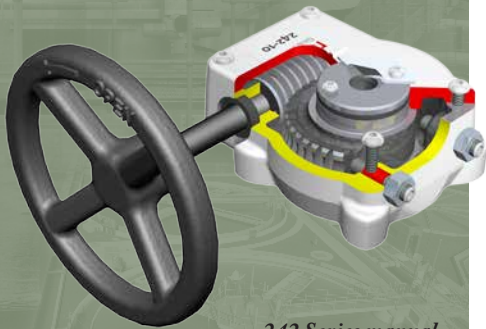

242 Series manual quarter-turn gear operators.

THE VALVES WERE FREE-ISSUED TO Houston where Rotork Site Services assisted with the mounting and testing of the limit switches for the customer's third-party witness test.

The 242 Series manual quarter-turn gear operators benefit from the latest design technologies to provide optimum robustness and durability with minimal non-structural mass and reduced overall size. They are ideally suited for low torque manual quarter-turn applications. ■



Rotork Skilmatic electro-hydraulic valve actuators are designed specifically for failsafe ESD (Emergency Shutdown) duties.

CHINESE PIPELINES SELECT SKILMATIC ELECTRO-HYDRAULIC VALVE ACTUATORS FOR REMOTE OPERATED FAILSAFE DUTY

Rotork Skilmatic electro-hydraulic valve actuators have been ordered for increased safety ESD (Emergency Shutdown) duties on two new oil pipelines in China.

OWNED BY THE CHINA NATIONAL PETROLEUM CORPORATION, the Mahui and Yunnan Pipelines are attached to the network bringing oil and gas to China from offshore fields in the Bay of Bengal.

The Skilmatic actuators will be installed in automated and unattended valve chambers at pump stations, where they will provide isolating and failsafe ESD functions. These valves, known as ROSOV (Remote Operated Shut-off Valves), are designed to isolate sections of the pipelines in the event of a potential emergency. By providing swift and accurate valve movement in one direction and very reliable mechanical spring return movement in the failsafe direction, Rotork's self-contained electro-hydraulic actuator design is successfully utilised for this type of critical application in many countries.

The Skilmatic actuator combines reliable failsafe performance with the benefits of Rotork IQ intelligent electric

actuation technology, facilitating remote supervision with a high level of asset management encompassing accurate control, monitoring and alarm signalling, operational data logging and diagnostics. The ESD function can be configured to operate on loss of mains power or control signal, with additional options including a second, independent ESD circuit and an ESD manual reset also available.

Designed for functional safety applications SIL 2 with a HFT 0 to IEC 61508:2010 the Skilmatic actuator is also offered with a partial stroke testing capability, enabling the valve to be function tested without interrupting the process - performed either locally or remotely from the control room. The actuator is available with worldwide hazardous area certification, whilst the double-sealed electric enclosure is watertight and dustproof in ratings up to IP68 (submersion at 7 metres for 72 hours). ■

CONTRACT NEWS

ROTORK ACTUATORS PERFORM VITAL FIRE SAFETY DUTY ON THE ISTANBUL METRO

High temperature specification Rotork RC200 scotch-yoke pneumatic actuators have been ordered for a vital fire safety duty in new subway tunnels under construction for the Istanbul Metro.

THE ISTANBUL SUBWAY SYSTEM in Turkey is undergoing a significant expansion programme involving 900 kilometres of new routes that are due for completion by 2023. Tunnels on the new routes are fitted with ventilation dampers in sizes up to 2 metres square. To meet stringent safety standards, the actuators operating these dampers must be able to rapidly close them and shut off the airflow in the event of a fire.

Rotork RC200 pneumatic actuators were selected for this application due to their compact design, fast operating



Rotork RC200 pneumatic actuators provide a vital fire safety duty on the expanded Istanbul Metro.

capability, long term reliability and minimum maintenance requirement. In addition, the actuators had to pass the stringent temperature and cycling tests required to meet the high level of safety demanded by the application. These included heating the actuator from -5 °C to +250 °C in only 20 seconds and then

confirming reliable operation with no air leakage for a minimum period of one hour at the maximum temperature.

Successful completion of the tests has led to the supply of several hundred actuators to the damper manufacturer in Turkey, Elektroteknik Klima Sanayi ve Ticaret A.S. ■

Following extensive testing, leading glass container manufacturers are specifying the Rotork CMA electric actuator for a critical valve control function in the glass making process.

THE VALVES ARE USED TO CONTROL the temperature and pressure in the furnaces by regulating the air and gas mixture with extreme precision. Maintaining a constant temperature and pressure is essential for energy efficient glass making. Traditionally, the industry uses a variety of actuators for the modulating and isolating valves involved, but has recognised the need for a more reliable and energy efficient universal solution for this application.

Tests have demonstrated that the CMA out-performs existing equipment, providing improved precision, reliability

ROTORK CONTROL VALVE ACTUATION PASSES THE GLASS MAKING TEST

and energy savings in a compact and easy to set product that is available in a range of sizes that suits all the various valve types encountered. In addition, the CMA's versatile ability to interface with industry-standard 4-20 mA or RIRO (Remote In Remote Out) control signals enables plants in different countries to standardise on the same product.

Furnace revamps, usually taking place after a period of ten years operation, provide the opportunity to introduce the upgrade, which typically involves up to forty valves on each furnace. Following the success of the tests, several hundred ATEX certified explosionproof CMQ250 and CMQ500 actuators have been installed during revamps around the world. ■



Rotork CMA electric control valve actuators have been installed during glass making furnace revamps around the world.

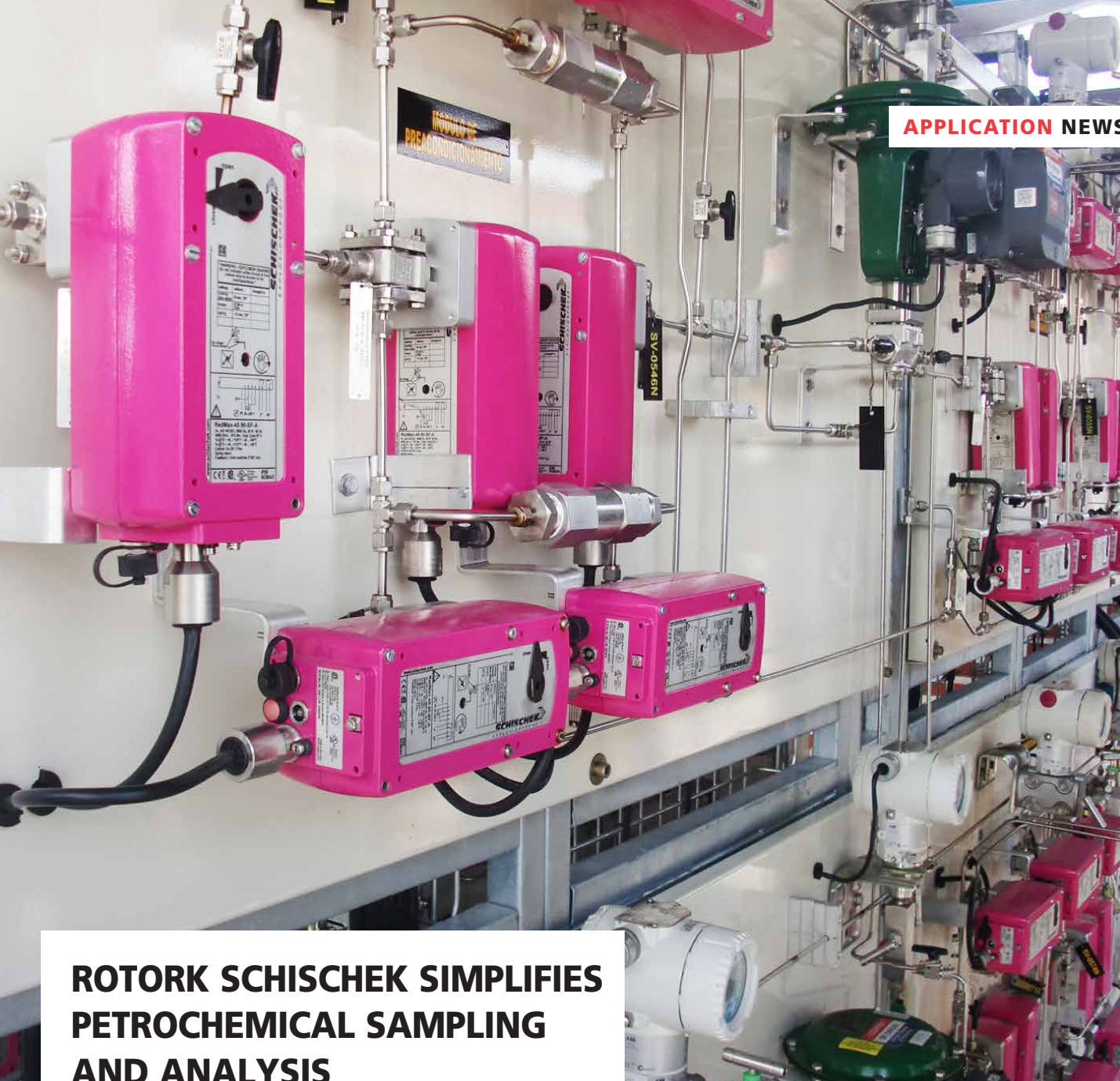

ROTORK SCHISCHEK SIMPLIFIES PETROCHEMICAL SAMPLING AND ANALYSIS

Rotork Schischek compact explosionproof valve actuators have been selected as the reliable solution for a critical petrochemical analysis process.

A wall of Schischek RedMax actuators in one area of the Ecopetrol NIR sampling and analysis plant, illustrating how their compact dimensions facilitate a neat and simplified installation.

ECOPETROL IS THE LARGEST PETROLEUM COMPANY IN Colombia, engaged in oil and gas exploration, production and refining. The company uses Near Infrared Spectroscopy (NIR) to perform quantitative sampling separation of hydrocarbons. The process separates the hydrocarbons into four chemical groups – alkanes, aromatics, resins and asphaltenes.

Central to the operation of the process, sets of small two and three-way fast acting ball valves are used to gather the samples for analysis and precisely maintain the pressure, flow and

temperature through the spectrometer. Swift valve operation (typically less than three seconds) is essential to maintain the characteristics of the media for accurate sampling. Additional application constraints involve restricted spaces around valves, the hazardous area classification and requirements for failsafe operation, end of travel indication and low power consumption.

After considering the other options, Ecopetrol concluded that the electric Schischek actuator could satisfy all these demands with a reduced maintenance requirement in the demanding operating

environment. Almost 100 Schischek RedMax actuators with associated hardware have been installed; the actuators are certified for Zones 2 and 22 hazardous area operation, environmentally protected to IP66 and equipped with self-adaptable 24 – 240 VAC / VDC power supplies.

RedMax actuators are one of a range of electrical products designed by Schischek for explosionproof and non-explosionproof applications in the worldwide industrial, HVAC and marine industries. ■

CONTRACT NEWS



The FPSO order from COSCO includes compact Rotork CP pneumatic actuators with Soldo switchboxes.

EFFICIENT SOLUTION AND LOCAL SUPPORT SECURES CONTRACT

Rotork has won the actuation contract for multiple automated valves for critical topside equipment applications on an FPSO under construction in China for a South American oil company.

THE ORDER FROM COSCO (DALIAN) SHIPYARD IS FOR 188 certified CP, GP, GH and RH range pneumatic and hydraulic actuators, for installation on gas compression modules. Five automated valve packages consist of pneumatic and hydraulic shutdown ESD ball valves, on-off ball and butterfly valves and blowdown ball valves, handling hydrocarbon gas, liquid chemicals and seawater.

Close co-ordination between Rotork offices in Brazil and China enabled the company to identify and propose a robust and efficient solution to the demands of the applications, using proven heavy-duty modular products including compact CP actuators specially designed for smaller valves.

Rotork's long term relationship with the end user and the high level of local support from Rotork that COSCO has experienced in China also made important contributions to the award of the contract. ■

VALVEKITS' LARGEST SPOOL KIT, BUILT ON THE HIGHEST QUALITY FOUNDATIONS

The largest spool kit made by Rotork Valvekits to date is manufactured from 316 grade stainless steel, and designed for the attachment of a Rotork GP350C scotch-yoke pneumatic actuator to a 56 inch, ISO Class 300, triple offset butterfly valve. By comparison, the small mounting kit shown in the photograph attaches a Rotork GT rack & pinion actuator to a ½ inch ball valve.

WHATEVER THE SIZE, VALVEKITS DESIGNS AND manufactures products in a full range of materials to meet customers' specific requirements. All designs are produced in-house by highly trained design teams, using the latest CAD facilities. Products are designed and manufactured to the exacting standards of ISO 9001 and can be supported with stress calculations and final-element analysis for customer peace of mind.

Valvekits is the only specialist valve adaption company with manufacturing facilities in the UK and the USA. At both sites manufacturing is performed using the latest CNC machinery and lathes and supported by a continuous investment plan for new machinery, keeping the company at the forefront of technology.

Swift delivery is another Valvekits service benchmark. The company's website enables customers to obtain a same-day quotation in most cases, often enabling delivery to be achieved within 48 hours. ■



Drax Group, the largest conventional power station in the UK, is converting to burning sustainable biomass in place of coal – a process which has seen the station transform from the UK's largest emitter of CO₂ to Europe's largest decarbonisation project.



ROTORK MIDLAND ASSISTS DRAX WITH EUROPE'S LARGEST DECARBONISATION PROJECT

A MAJOR PART OF THIS PROJECT IS THE INTRODUCTION OF NEW RAIL FREIGHT wagons, designed by Lloyd's Register Rail and capable of carrying over 70 tonnes of compressed wood pellets, a 30% increase over conventional wagons. Over 200 of these new wagons have been manufactured in the UK by WH Davis Ltd., each equipped with a fully automated pneumatic control system manufactured by Rotork Midland.

The Rotork Midland design enables all controls, hand valves and visual indicators to be located in one place, providing safe and convenient access. The innovative design allows any wagon in the rake (group of connected wagons) to be the arming wagon (the wagon that initiates the operation of the hopper doors). Top and bottom hopper doors are operated by a magnetic sensor valve from a lineside magnet.

The system design also allows for wagons to be separated and used in other rakes without any further configuration. ■

Rail freight wagons capable of carrying over 70 tonnes of compressed wood pellets.

"The fully automated control system allows quicker loading and unloading, requiring only supervision without manual intervention during the process."

LARGE SOLDO ORDER FOR EGYPTIAN POWER GENERATION INDUSTRY



*Soldo XA
Limit Switchbox.*

Soldo has won an order for approximately 1,600 limit switchboxes for installation at the South Helwan Power Plant in Egypt.

THE SOUTH HELWAN POWER PROJECT is designed to increase efficient power generation capacity in Egypt. The project includes a 1,950 MW supercritical steam technology power plant fuelled by natural gas as the primary fuel and by Heavy Fuel Oil (HFO) as a backup.

Egypt has experienced rapidly growing electricity demand due to population growth, the development of energy-intensive industries and the use of electrical household appliances - particularly air conditioning. The power station will contribute 10% of new electricity generation capacity which is to be added by 2018, helping to deliver a more reliable supply to the Egyptian economy.

The additional electricity generated by South Helwan will be distributed to grid-connected consumers throughout the country.

The project is part of a broader programme which aims to help the country deal with energy policy issues as well as meet the growing electricity demand in a sustainable manner. The programme includes investments in power generation, transmission and distribution, energy efficiency and subsidy reform.

The Engineering, Procurement & Construction (EPC) Contractor for the South Helwan Power Plant is Techint. AC BOILERS (formerly Ansaldo Caldaie) has been awarded the contract for 3x 650 MW supercritical gas/oil fired boilers for the project, with Alfa Valvole supplying the majority of the valves. ■



PRODUCT NEWS

ROTORK INTRODUCES A REVOLUTIONARY WIRELESS VALVE MONITORING CONCEPT

RI Wireless is a revolutionary concept for wireless valve monitoring and diagnostics in the process industry.

THE FIELD PROVEN SOLUTION transmits real-time position indication to the control room and enables predictive maintenance for actuated valves, delivering capital and operating expenditure reduction, increased safety and increased productivity.

Designed for new and existing plants in the process industries and utilities, RI Wireless products are certified as Zone 1 Intrinsically Safe for use in hazardous areas. By introducing comprehensive plant monitoring, the system enhances operational efficiencies and eliminates unnecessary shutdowns. Predictive maintenance is facilitated through the monitoring of valve opening and closing profiles and the detection of variations from reference profiles.

The system comprises of a small, battery powered Valve Monitoring Device (VMD) that is installed on existing or new valve actuators using a NAMUR interface, or on manual valves with an ISO 5211 interface. The VMD collects dynamics-of-state data from the actuator or valve and transmits it as a 64-point packet, providing the information required

for preventative maintenance. A network of Valve Device Routers (VDR) transfer the monitoring data from the VMDs on a wireless MESH network to the Tunneling VDR (TVDR), which is the 'last hop' VDR that transfers the data to the RI Wireless Gateway, an industrial computer that manages the RI Wireless system. Several TVDRs can be connected to the RI Wireless Gateway via Transmission Control Protocol (TCP) or Internet Protocol (IP) networks.

The final element in the structure is the RI Wireless Management System (WMS), a software management tool that provides operational and maintenance data in common industrial standard connections to a HMI, DCS or PLC.

The system is programmed and commissioned using a hand-held Operator Device (OD) instrument that provides one-to-one wireless communication with the VMDs. In addition to supporting installation and configuration, the primary functions of the OD are turning devices on and off and receiving real-time feedback regarding the status of individual VMDs. ■

INNOVATIVE ROTORK GEARBOX WITH SAFEOPERATOR FLEXIBLE EXTENSION ENABLES CRITICAL SUBSEA VALVE OPERATION



The innovative combination of Rotork gearboxes and SafeOperator flexible extensions has successfully and economically enabled the manual operation of critical ballast valves on an offshore platform.

A MAJOR BUILDER OF TLPs (TENSION LEG Platforms) needed to manually operate sixteen submerged ballast valves deep in the legs of the platform. Rotork Gears met the challenge with an IP68 rated submersible IS multi-turn spur gearbox combined with the SafeOperator flexible extension solution for valve operation. The combination of flexible and rigid shafts has enabled the valves to be operated from a safe platform 40 metres away. In addition to operating the valve, the system also provides clear visual indication of open or closed positions.

The Rotork IS gearbox selected for the application is rated for continuous submerged duty at a depth of 40 metres and is fitted with a simplified subsea pressure compensator relief valve. The SafeOperator is manufactured from a standard range of stainless steel components for maintenance-free operation in the harsh sub-sea environment. Fabrication was performed by Rotork Valvekits, who also manufactured the valve mounting bracket for the gearbox.

SafeOperator systems offered in combination with Rotork gearboxes are customised to suit individual requirements and enable the manual operation of valves of virtually any size that are hard to reach or in dangerous areas from a place of safety without the need to compromise on the pipe layout or build additional infrastructure. Each system is designed for easy installation and long term maintenance-free operation. ■



Aberthaw Power Station.

Rotork valve actuators are helping the RWE Aberthaw Power Station in South Wales to be maintained as one of the most efficient coal fired stations in the UK. Aberthaw can generate around 1,555 MW of electricity for the National Grid System, which is enough power to meet the needs of some 3 million households.

ROTORK ACTUATORS SUPPORT THE ENVIRONMENTAL IMPROVEMENT PROGRAMME AT ABERTHAW POWER STATION

FOLLOWING THE INTRODUCTION OF FGD (Flue Gas Desulphurisation) which has reduced sulphur emissions by up to 95%, the latest stage of Aberthaw's multi-million pound investment for the improvement of environmental performance involves the installation of Lo NOx technology, in line with the latest Industrial Emissions Directive. Aberthaw is the first UK coal fired station to go down the Lo NOx route, which will further extend its future operational life.

The system is designed to maximise NOx reduction efficiency and minimise the impact on combustion performance and operation. The first unit, including 120 Rotork IQ and IQT multi-turn and part-turn intelligent electric actuators to control the operation of valves and dampers, has been installed on one of Aberthaw's three 535 MW generating sets.

The Rotork actuators were specified for the application by the engineering staff at Aberthaw. The decision was influenced by the long history of reliability demonstrated by the Rotork actuators already installed on site, which account for over 90% of the site's total quantity of actuation assets.

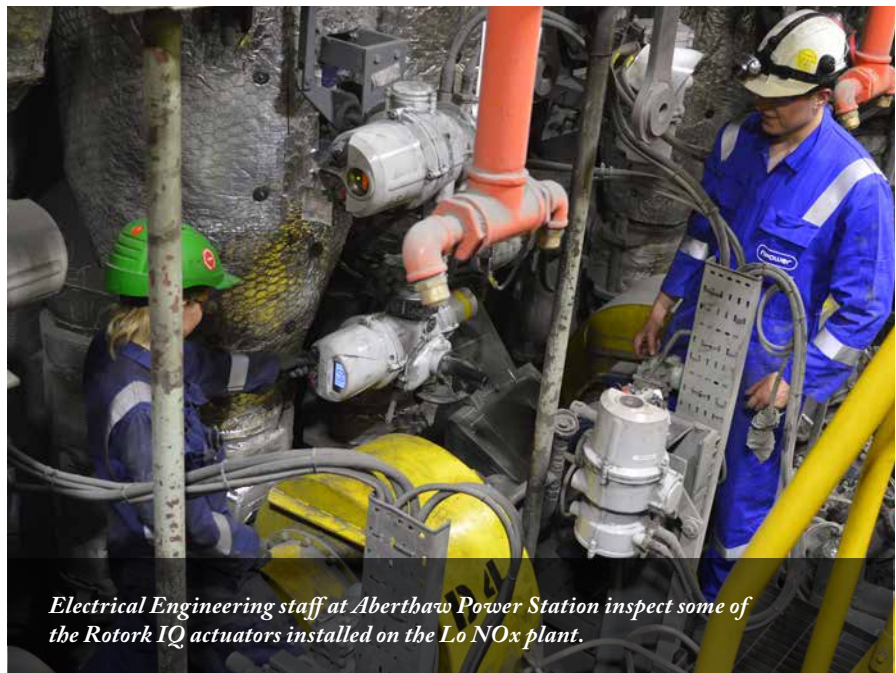

Electrical Engineering staff at Aberthaw Power Station inspect some of the Rotork IQ actuators installed on the Lo NOx plant.

Rotork double-sealed and non-intrusive actuators are designed to withstand challenging operating environments such as those often encountered in the power generation industry with minimum maintenance. In addition, IQ intelligent actuation technology incorporates comprehensive datalogging abilities, enabling operating data to be downloaded and diagnosed for the

optimisation of preventative maintenance and asset management.

The Aberthaw Lo NOx system was manufactured by Foster Wheeler, installed by Doosan and commissioned at the end of 2015. Rotork Site Services performed the actuator commissioning in a contract with the electrical sub-contractor J W Morris Ltd. ■

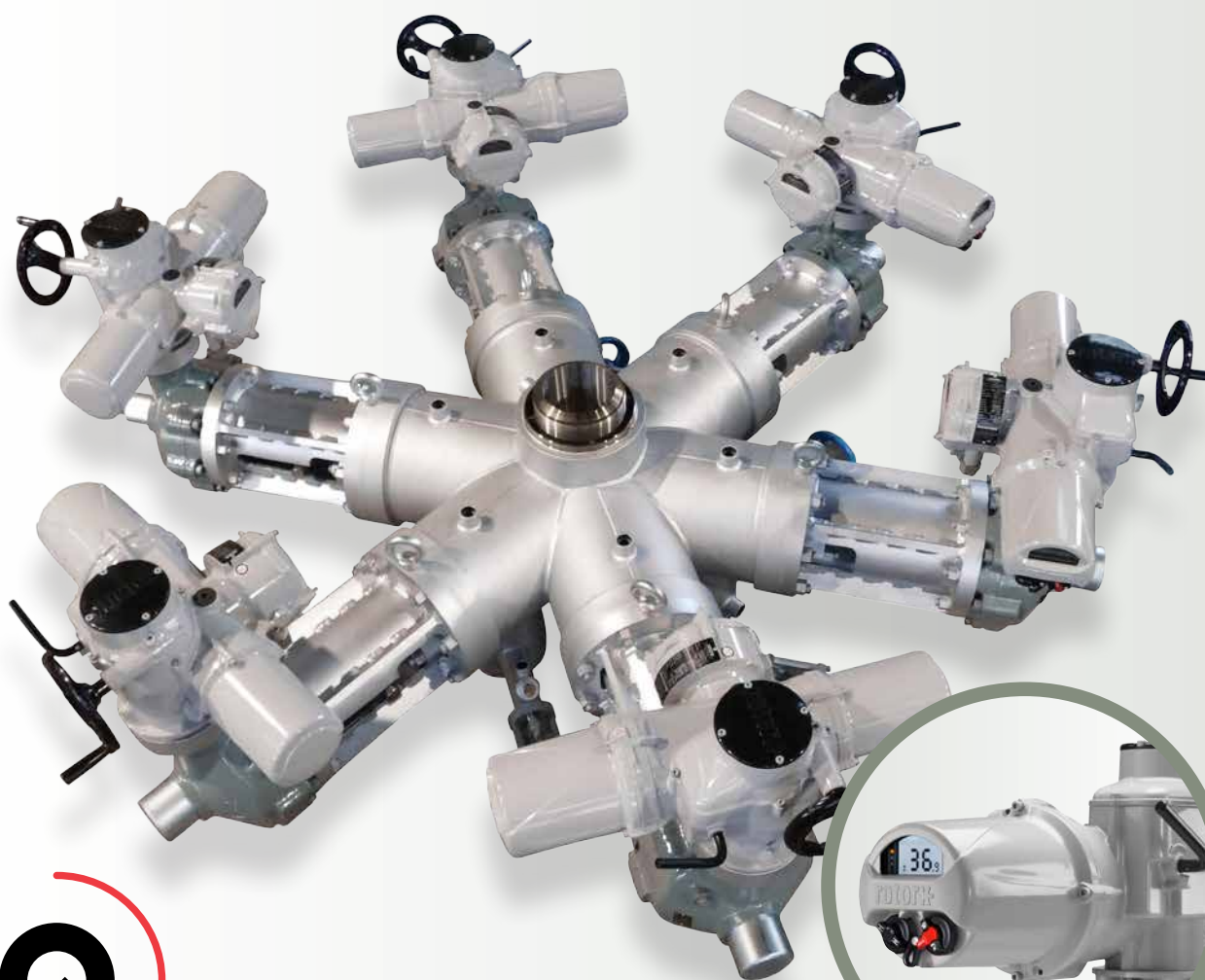

ROTORK JAPAN PROVIDES THE INTELLIGENT ACTUATION SOLUTION FOR WORLD'S FIRST SEVEN-WAY CONTROL VALVE

ROTORK JAPAN HAS SUPPLIED IQ3 intelligent valve actuators for the automation of what is said to be the world's first seven-way control valve. The innovative valve, manufactured in Japan by the Aska Corporation, operates under high pressure to control and regulate the flow of chemicals such as polymers, reducing the load on instrumentation in the downstream manufacturing processes.

The unique radial design of the valve eliminates any dead space (no flow)

areas which could erode the quality of the media. The design demands a compact actuation solution that is capable of delivering swift and precise valve movements with high operating torques. The high viscosity, temperature and pressure of the media being controlled are further factors that contribute to the challenging demands of the application.

The selection of Rotork IQ3 intelligent actuation for the automation of the valve has successfully fulfilled these challenges.

The proven long-term reliability of the IQ3 in similar harsh and high temperature hazardous area environments made an important contribution to the valvemakers decision to specify Rotork for this application. Other significant considerations included the IQ3 actuator's versatility, functionality and asset management capabilities, combined with swift and simple commissioning procedures, accessed via secure non-intrusive communication technology. ■

EH ACTUATORS PROVIDE SAFETY SHUT-DOWN DUTIES FOR THE KOREAN GAS CORPORATION

Rotork Korea has successfully delivered, installed and commissioned the first two of three specialised EH (Electro-Hydraulic) valve actuators providing vital safety shut-down duties at an LNG installation operated by the Korean Gas Corporation (KOGAS).



AS THE KOREAN NATION'S ONLY LNG SUPPLIER, KOGAS operates four LNG terminals and a nationwide pipeline network spanning over 4,240 km. The Rotork EH actuators were selected as the solution to replacing DC actuators at a pipeline valve station. The critical nature of the shut-down application demands an Uninterruptable Power Supply (UPS), for which the self-contained EH actuator has provided an economical and reliable solution.

In addition to the reduced power consumption associated with the operation of the EH actuators, the use of hydraulic accumulators to provide the UPS function has reduced the capacity, size and construction costs associated with the UPS installation. The customised Emergency Shut-Down (ESD) input enables a full close-open-close operating cycle from the stored energy source. ■



Two site photos of the Rotork EH actuator installations at the KOGAS valve station.



SCOTTISH WATER SELECTS ROTORK FOR NEW VALVE ACTUATION FRAMEWORK CONTRACT

Following a formal tender process, Scottish Water has awarded the framework agreement for new valve actuators to Rotork UK. The agreement appoints Rotork as the supplier of new actuators to Scottish Water and its business partners, valvemakers and appointed contractors for the SR15 cycle.

THE NEW FRAMEWORK COMPLEMENTS AN EXISTING agreement that provides servicing and spares for the several thousand Rotork actuators installed throughout the Scottish mainland and islands, encompassing on-site and workshop support as well as mechanical and electrical capabilities for system integration into client infrastructure.

Strategic to both frameworks' success is Rotork UK's recently opened Glasgow office, which offers Scottish Water a local centre for enhanced, faster and more economical support.

Comprehensive workshop facilities provide repair and overhaul services, stocks of spare parts and a valve automation centre

for manual valve automation, actuator replacement and the provision of new actuated valves.

Scottish Water manages over £58 billion of assets to provide 2.5 million customers with water and effluent treatment services. Around £10 billion of these assets are treatment works and pumping stations, of which about 50% have been built in the last 20 years. Many of the processes in these facilities utilise Rotork IQ intelligent multi-turn and part-turn valve actuators and Profibus control networks to assist with high levels of automation and provide diagnostic and preventative maintenance functions. ■



ROTORK ELB ELECTRONIC LINE BREAK COMBINES PIPELINE PRESSURE MONITORING WITH INTELLIGENT VALVE CONTROL

Designed for use in the oil and gas industries, the Rotork ELB is a robust, self-contained instrument that combines pipeline pressure monitoring with intelligent valve control. The ELB can also collect detailed operational data for optimising performance and enhancing pipeline safety.

THE ELB CONTINUOUSLY MONITORS UPSTREAM AND downstream pipeline pressure dynamics to provide early detection of pipeline breaks and initiate automatic valve actuator movement to an emergency position, based on user-defined parameters. Valve actuator control - selectable as fail close, fail open or stay put - is based on rate-of-drop (RoD) and rate-of-rise (RoR) as well as high and low pressure limits.

A remote process shut down (PSD) input with the option to override all functions is also available to drive the valve to the fail position. The ELB also provides an array of programmable alarm and alert indications and has an extensive range of features that can be configured to meet end users' specific requirements. These include up to six remote inputs and four

The Rotork ELB continuously monitors upstream and downstream pipeline pressure dynamics to provide early detection of pipeline breaks and initiate automatic valve actuator movement. It is shown (on the left side of the picture) attached to a Rotork Gas-over-Oil pipeline actuator.

configurable solenoid outputs, partial stroke testing (PST) and Modbus® network connectivity.

The ELB is housed in a compact, environmentally sealed and explosionproof housing that can be mounted on the actuator or remotely. Setting menus displayed on the large HMI window are the focus for non-intrusive programming and commissioning using Rotork IQ intelligent electric actuation technology. In normal mode the LCD display indicates valve position. The same window also displays visual indication of status, alarms, event, trend and operation logs and diagnostic data. Padlockable pushbuttons for local actuator operation are provided on the ELB enclosure and a vandalproof cover is available for increased security. ■

PRODUCT NEWS

COMPACT EXPLOSIONPROOF PART-TURN ELECTRIC VALVE ACTUATOR EXTENDS THE ROTORK RANGE



The new Rotork ExMax valve actuator has been introduced for the economical operation of small part-turn valves and dampers in exposed environments and hazardous locations.

DEVELOPED FROM THE WELL-ESTABLISHED ROTORK Schischek HVAC actuator design, the Rotork ExMax valve actuator delivers reliable part-turn performance in a compact, lightweight and rugged watertight package with hazardous area certification and a failsafe option.

Innovative standard features include a universal power supply, selectable between 24 and 240 VAC or VDC, a choice of five operating speeds, auto set-up and a simple, environmentally sealed flying lead electrical connection. The standard IP66/67 dust and watertight enclosure is ATEX or IECEx certified for hazardous area operation in gas and dust zones 1, 2, 21 and 22.

Spring-return failsafe operation is available in the clockwise or anti-clockwise directions. For critical duties, the speed of the failsafe stroke can be increased to give a closing time of one second. A detachable handwheel for manual operation can be specified in a range of options also including ISO or DIN standard mounting flanges, integrated auxiliary position indication switches, stainless steel enclosures and offshore marine paint finish. A non-hazardous area watertight enclosure is available when explosionproof certification is not required.

In double-acting configurations, the two models in the ExMax valve actuator range deliver an output torque range of 5 to 150 Nm. Failsafe actuators deliver up to 60 Nm (50 Nm for fast-acting failsafe versions). ■

IQTF INTELLIGENT CHOKE VALVE ACTUATOR



The IQTF non-intrusive intelligent electric actuators is designed specifically for choke and control valve applications.

THE IQTF IS ENGINEERED TO PROVIDE THE high accuracy, resolution and reliability demanded by arduous applications associated with oil & gas fields and general process control management.

The standard specification delivers up to 1,800 starts per hour with adjustable speed control, micro-step motion, 0.1% resolution and 0.3% accuracy. The compact and lightweight design is adaptable for direct mounting on rotary, rising stem and linear valves and operates with low power consumption on single- and three-phase AC or 24 VDC power supplies. Output torque ranges from 50 to 3,000 Nm (37 to 2,214 lbf.ft).

The IQTF incorporates all of the advanced functionality and asset management features for which the Rotork IQ marque is well known, including an unrivalled range of data logging capabilities. An information-rich backlit display is the focus of attention for non-intrusive wireless commissioning, communication and multi-functional indication, including user-friendly multi-lingual menus for setup and configuration. Local position indication, valve and actuator status, asset management and diagnostic operating information can be viewed directly at the actuator and downloaded. Diagnostic graphics showing the valve torque, usage profiles and service logs facilitate real-time analysis directly at the actuator or in the control room. These features enable preventative valve maintenance to be scheduled, eliminating unplanned outages and downtime at your plant.

Reliability is optimised by the IQ double-sealed IP66/IP68 (20 m for 10 days) enclosure, which permanently protects internal electrics from the ambient environment, even during site wiring with the terminal housing cover removed. Hazardous area certification is available to international standards. An advanced patented absolute encoder measures the position, so there is no loss of position even without power.

In addition to analogue and hard wired control options, IQTF actuators offer network connectivity with Foundation Fieldbus®, Profibus®, HART® and DeviceNet® open systems, as well as Rotork's own dedicated Pakscan™ wired or wireless systems. ■

PRESSURE SAFE® LINE BREAK DETECTION

The Rotork Pressure Safe® failsafe hydraulic control system introduces an economical and reliable line break detection solution for remote pipeline or wellhead valves and critical process applications where mains electricity or fluid power sources are not available or unreliable.

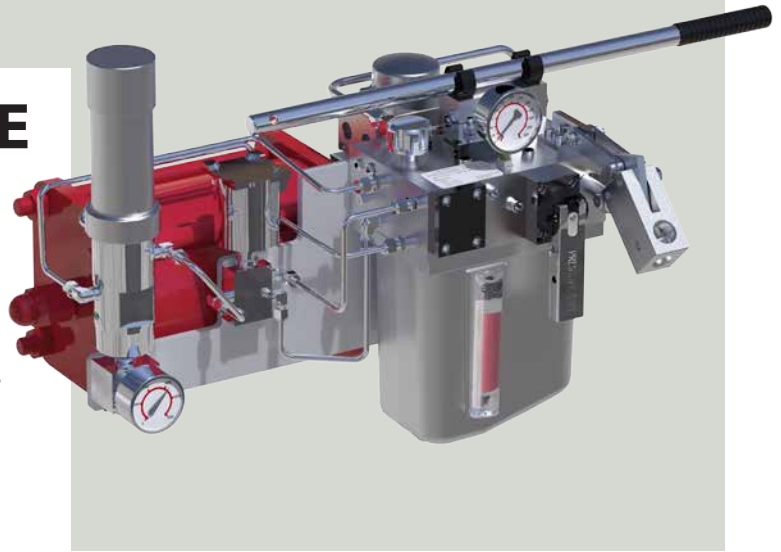

THE COMPACT, SELF-CONTAINED PRESSURE SAFE® PROVIDES Emergency Shutdown (ESD) protection by automatically exhausting spring-return actuator pressure when pipeline pressure exceeds a high or low level set-point. The failsafe actuator can be linear or quarter-turn, fail open or close, with cylinder operating pressure up to 3,000 psi. The Pressure Safe® hydraulic control system is has a 3-way high and low pressure pilot valve which will trip the control system when line pressure

is outside of the normal operating range. This is ideal for use as the final mechanical element in safety systems designed in accordance with IEC 61508 and IEC 61511. When combined with a solenoid or process sensor the control system can provide automatic process control based on one or more process variables including pressure, temperature, level, velocity and chemistry. An integral hand pump is fitted for re-pressurising the actuator and the unit's dump valve can be manually opened. ■

THE SI ELECTRO-HYDRAULIC 3rd GENERATION FAILSAFE ACTUATOR

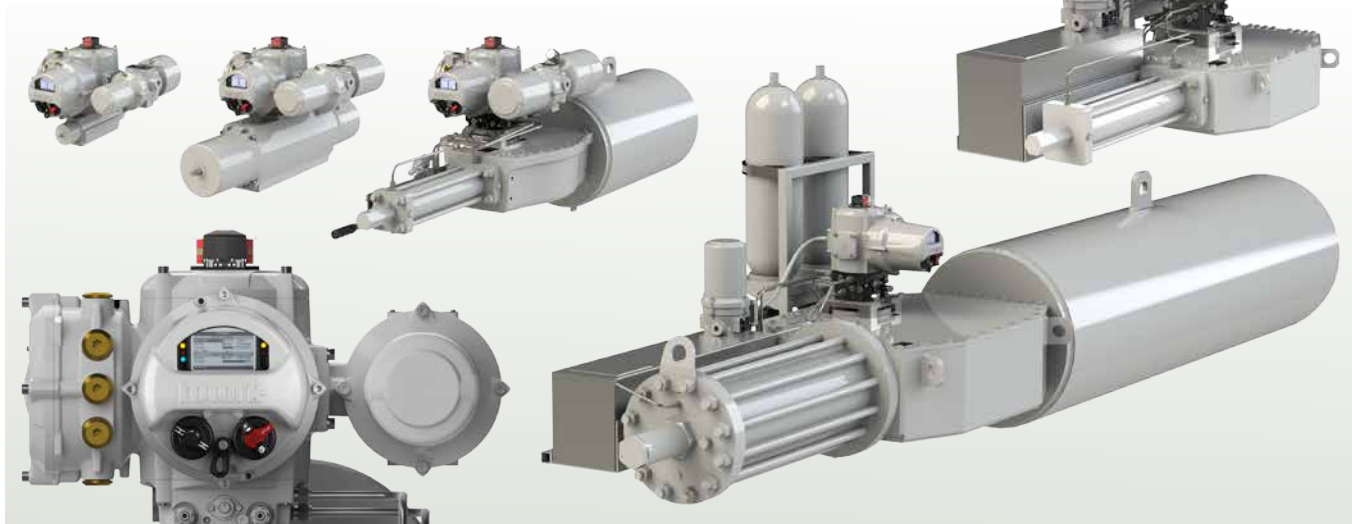

THE SI ELECTRO-HYDRAULIC 3RD GENERATION FAILSAFE actuator now consists of four models with multiple actuator sizes known as SI₃-1, SI₃-2, SI₃-3 and SI₃-4, enabling Rotork to offer quarter-turn failsafe actuation from 65 Nm up to 600,000 Nm for functional safety applications. As part of the development Rotork has enhanced the range by introducing

the new SI₃-3 standard range of spring return actuators with a torque range of 2,000 Nm to 20,000 Nm.

This new range offers a wide choice of operating speeds, additional ESD options with single or dual inputs and enhancements to partial stroking to meet a wide range of applications. ■

DOUBLE BLOCK AND BLEED VALVES

The Bifold range of Monoflange and Double Block and Bleed (DBB) products is designed for both instrumentation and process applications.

Bifold range of Monoflange and Double Block and Bleed (DBB) products.

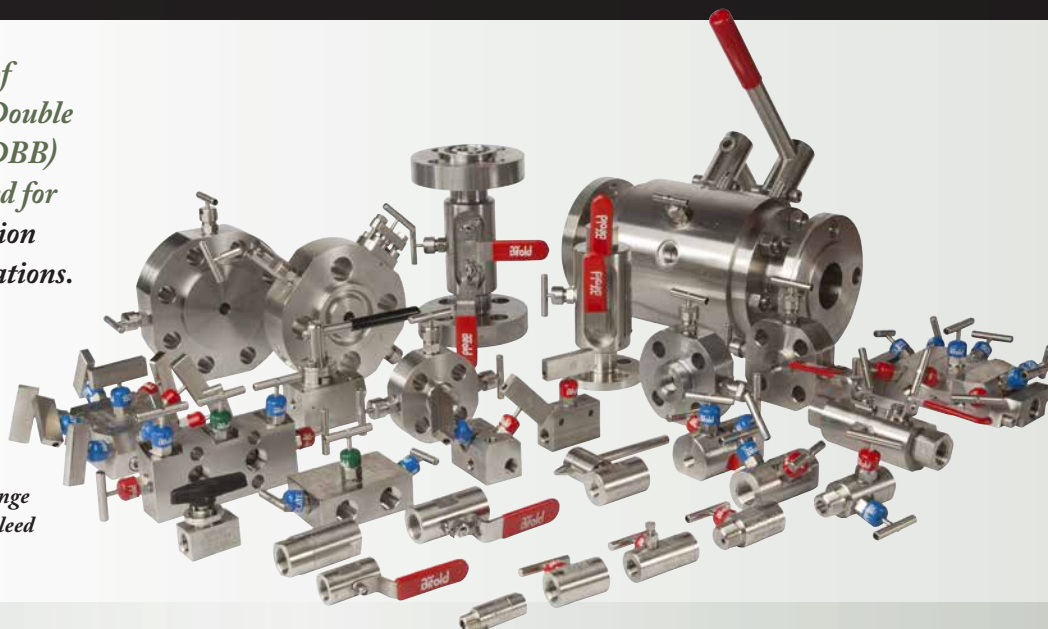

DEVELOPED TO OVERCOME THE PROBLEMS OF traditional assemblies on primary isolation and venting duties, the design combines customer specified valves into a single manifold.

The number of leak paths is reduced, resulting in a one unit solution which also offers a smaller installation envelope, reduced weight and cost saving. ■

MEDIUM PRESSURE PRODUCT RANGE

THE PRODUCT RANGE INCLUDES needle valves, ball valves, trunnion style double block and bleed manifolds, check valves, fittings and adaptors, actuated ball and needle valves, thermal and precision relief valves, electric motor driven pumps, air driven pumps, pressure intensifiers, direct and indirect acting solenoid valves, quick exhaust valves, air piloted directional control valves and pressure transmitters.

Designed with innovative features for reliable high pressure operation and incorporating many standard features from proven product lines, Bifold's medium pressure products are proving to be far superior to conventional products on the market. ■

Bifold Medium Pressure Products deliver safe, reliable operation to 20,000 psi / 1,379 bar and provide all the components required for building medium pressure testing and/or control systems from a single source.



Check valves and Medium pressure valve product range.

APPOINTMENTS

NEW DIVISIONAL SALES DIRECTOR FOR ROTORK FLUID SYSTEMS AND NEW BUSINESS DEVELOPMENT DIRECTOR FOR ROTORK INSTRUMENTS

Aitor Laso has been appointed Divisional Sales Director for Rotork Fluid Systems.



Aitor's career at Rotork began over 24 years ago and in that time he has gained in-depth sales experience with electric and fluid power actuator products in diverse market areas.

He has held the position of General Manager for Rotork Iberia and prior to his new appointment was Regional General Manager for Europe. In his new role he will direct and develop the sales of Rotork's expanding range of fluid power products and services in traditional and new markets around the world. ■

Andy Filkins is the new Divisional Business Development Director for Rotork Instruments.



Andy joined Rotork in 2014 as General Manager for Rotork Midland, where he has successfully integrated what was then a new acquisition into the Rotork Instruments division.

His previous career has included international business development responsibilities for manufacturers and distributors of control and instrumentation equipment in the power generation and flow control markets. His experience and knowledge of the marketplace stands him in good stead for recognising and exploiting new business opportunities for Rotork in worldwide industrial instrumentation industries. ■

ACQUISITIONS:

MASTERGEAR JOINS THE ROTORK GROUP



Rotork has recently acquired Mastergear, a leading manufacturer of manual and motorised gearboxes for valves focused on the oil and gas, water distribution and treatment, chemical processing and wider industrial markets. Mastergear has become part of the Rotork Gears division.

The Mastergear business has its main centres of operations in Italy and the United States, with a further operational presence in China. Since its formation in the early 1960s, Mastergear has developed a comprehensive range of gearbox products to suit a wide variety of environmental and operational specifications, ranging from general industry to buried service and subsea. Mastergear brings complementary products to the Gears division including large bevels, manual overrides and AWWA quarter turn gearboxes. ■

Commenting on the acquisition, Peter France, Rotork Chief Executive, said:

"Mastergear has a well-regarded product portfolio that will enable Rotork to offer its customers a more comprehensive range of products and services. The acquisition is in line with our strategy and strengthens our presence in the flow control sector, including the water distribution and treatment market."

rotork⁴²

UK
Rotork plc
tel +44 (0)1225 733200
fax +44 (0)1225 333467
email mail@rotork.com

USA
Rotork Controls Inc.
tel +1 (585) 247 2304
fax +1 (585) 247 2308
email info@rotork.com

For the latest news follow
Rotork on twitter @rotork

Rotalk is published and printed by
Rotork Controls Ltd. in the UK.

www.rotork.com