

rotork[®]

Keeping the World Flowing
for Future Generations

RH Range

Hydraulic Actuator
Single-Acting and Double-Acting Configuration

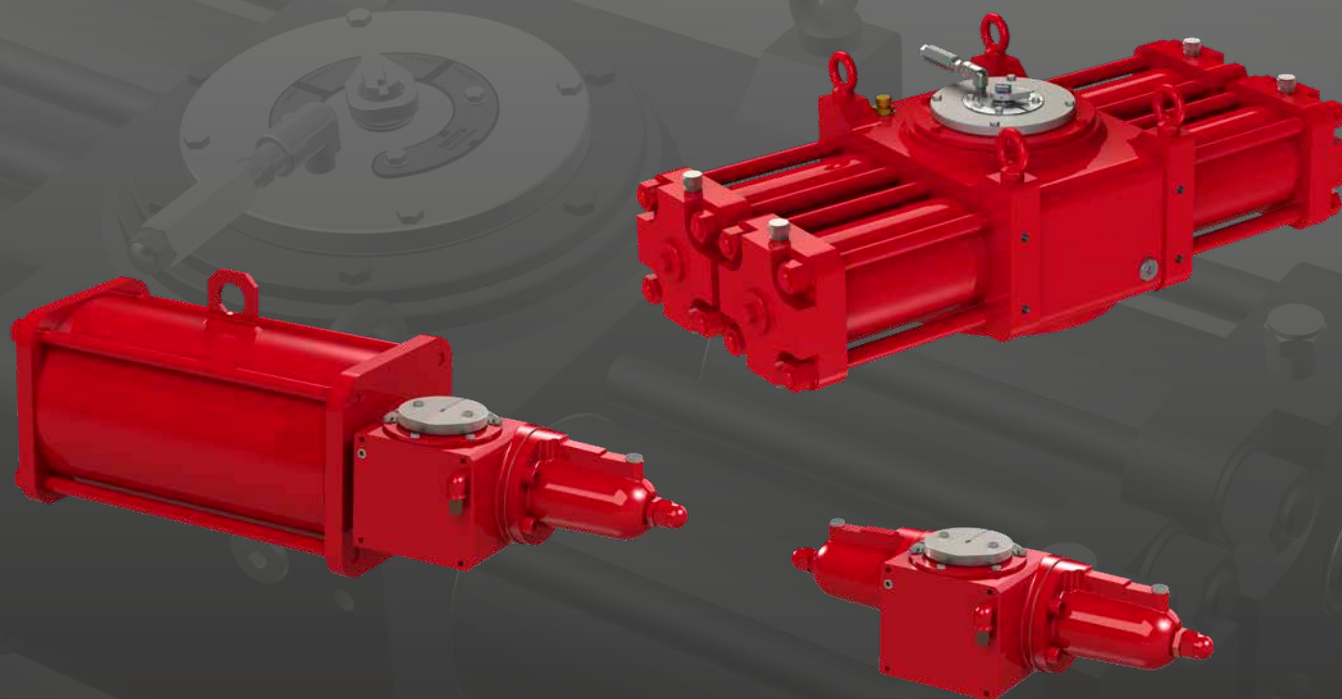

Installation, Commissioning and Maintenance Manual

Contents

Section	Page	Section	Page
1. Introduction	3	11. Removal from Valve	11
2. Standards and Regulations	3	12. Operation	12
3. General Information	4	12.1 Description	12
4. Health and Safety	4	12.2 Operating Description	14
4.1 Residual Risks	4	12.3 Actuator Code and Design	14
4.2 Thermal Risks	4	12.4 Manual Override	14
4.3 Noise	4	12.5 Angular Stroke Setting	14
4.4 Health Risks	4	12.6 Hydraulic Power Supply	18
4.5 Mechanical Risks	4	12.7 Hydraulic Connections	18
4.6 Magnetic Risks	5	12.8 Electrical Connections	19
4.7 Electrostatic Risks	5	12.9 Start Up	19
5. Labels and Nameplates	5	13. Dismantling and Disposal	20
6. Operating Limits	6	14. Rotork Sales and Service	20
6.1 Allowed Fluid Types	6	15. Troubleshooting	21
6.2 Expected Lifetime	6	16. Periodic Maintenance	22
6.3 Tightening Torque Chart	6	17. Part List	51
7. Handling and Lifting	7	18. Grease and Hydraulic Oil Specification	55
7.1 Lifting Recommendations	7	18.1 Grease	55
7.2 Lifting Instructions	7	18.2 Hydraulic Oil	56
8. Storage	9		
9. Long Term Storage	9		
10. Installation on Valve	10		
10.1 Preliminary Actions	10		
10.2 Instructions	10		



Single-acting actuator (body sizes 015, 030, 060, 120, 240)



Double-acting actuator (body sizes 015, 030, 060, 120, 240)

This manual contains important safety information. Please ensure it is thoroughly read and understood before installing, operating or maintaining the equipment.

Rotork reserves the right to modify, amend and improve this manual without notice.

Due to wide variation in the terminal numbering of actuator products, actual wiring of the device must follow the print supplied with the unit.

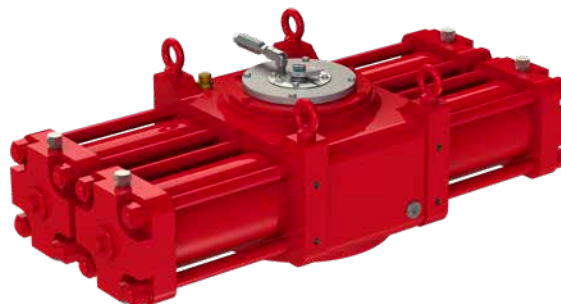

Double-acting actuator (body sizes 090, 105, 125, 145, 155, 185, 225, 250, 280)

1. Introduction

This manual covers maintenance aspects and instructions specific to the RH range of actuators. General information on Rotork actuators are described in the User Manual, delivered separately.

In this manual, warning indications are represented by icons, per ISO 7010 Safety Signs:



Generic danger



Hand crush/pinch point



Electrocution



Explosive material

2. Standards and Regulations

Actuators destined for European member states have been designed, built and tested per the Quality Control System, in compliance with the EN ISO 9001:2015 standard and with the following regulations/directive.

- 2006/42/EC: Machinery Directive
- 2014/68/EU: Pressure Equipment Directive (PED)
- 2014/34/EU: Directive for safety equipment and systems to be used in potentially explosive atmospheres (ATEX)
- 2014/30/UE: Electromagnetic Compatibility Directive
- EN ISO 12100: Machinery Safety Directive
- EN 60079-14: Explosive atmospheres - Part 14: Electrical installations design, selection and erection
- ISO 80079-36: Non-electrical equipment for explosive atmospheres - Basic method and requirements
- EN 1127-1: Explosive atmospheres – Explosion prevention and protection
- ISO 80079-37: Non-electrical equipment for explosive atmospheres - Non-electrical type of protection construction safety "c", control of ignition sources "b", liquid immersion "k"
- UNI EN ISO 7010: Safety Signals
- EN13445: Unfired Pressure Vessels

Customer Service

For technical assistance, please contact Rotork customer service:

E-mail: rfs.international@rotork.com

Rotork, Via Padre Jacques Hamel, 138B, Porcari, Lucca, 55016, IT. Tel: +39 0583-222-1

Rotork plc, Brassmill Lane, Bath, UK. Tel +44 (0)1225 733200

3. General Information

This manual is produced to enable a competent user to install, operate and maintain Rotork RH single and double-acting actuators.

The mechanical installation must be carried out as outlined in this manual and in accordance with any relevant national standard codes of practice.

Maintenance and operation must be carried out in accordance with the National Legislation and Statutory Provisions relating to the safe use of this equipment, applicable to the site of installation.

Any inspection or repair in a Hazardous Area must not be undertaken unless it conforms to National Legislation and Statutory Provisions relating to the specific Hazardous Area.

Only Rotork approved replacement parts should be used. Under no circumstances should any modification or alteration be carried out on the equipment, as this could invalidate the conditions under which certification was granted.

Only trained and experienced operators can install, maintain and repair Rotork Actuators. Work undertaken must be carried out in accordance with instructions in this manual. The user and those persons working on this equipment must be familiar with their responsibilities under any statutory provisions relating to the Health and Safety of their workplace.

Operators must always wear appropriate Personal Protection Equipment (PPE) in line with the existing plant regulations.

Appropriate usage

Rotork RH range actuators have been specifically developed to motorise ¼ turn valves, such as ball valves, butterfly valves or plug valves installed on pipelines for oil & gas transport and distribution.

⚠ Improper use can damage the equipment or cause dangerous situations for health and safety. Rotork declines any responsibility for damage to people and/or objects resulting from the use of the equipment for applications different from those described in the present manual.

4. Health and Safety

Before installing the equipment, verify it is suitable for the intended application. If unsure consult Rotork.

4.1 Residual Risks

Residual risks resulting from equipment risk evaluation performed by Rotork.

4.2 Thermal Risks

Risk Hot/Cold surface during normal operation.

Preventive measures Operators should wear protective gloves.

Risk In the presence of dust, equipment surface temperature must not exceed 2/3 of the ignition temperature of the dust. Dust ignition temperature is reduced by 75 °C if a 5 mm thick coating builds up.

Preventive measures Keep equipment surfaces clean by planning regular cleaning maintenance using a suitable wet anti-static cloth.

4.3 Noise

Risk Noise >85 dB during operation.

Preventive measures Operators must wear ear protections. Operators must not stand near the equipment during operation.

4.4 Health Risks

Risk Pressurised fluid ejection during normal operation.

Preventive measures All fittings must be properly sealed. All fixing clamps must be correctly tightened and sealed.

Risk Risk of intoxication (per the type of medium utilised).

Preventive measures Operators must use P.P.D.s and any other equipment (breathing apparatus) based on the type of supply medium.

4.5 Mechanical Risks

Risk Uncontrolled movement (remote operation). (This risk is applicable only for actuators provided with control panel).

Preventive measures Assure that the actuator cannot be operated remotely. Prior to starting, remove Hydraulic supply, vent all pressure vessels, and remove electrical power.

Risk Presence of moving parts (centre body, valve adapter).

Preventive measures Do not perform start-up or test the actuator if the cylinder tube is removed.

4. Health and Safety

Risk	Loss of stability with possible parts projection.
Preventive measures	Do not disassemble the actuator in case of malfunctioning. Follow instructions in the present manual and contact Rotork.
Preventive measures	Foresee periodic maintenance procedure to verify tightening.
Risk	Presence of potential energy during dismantling.
Preventive measures	Do not disassemble the actuator during dismantling. Follow instructions in the present manual and contact Rotork.

4.6 Magnetic Risks

Risk	Risk of magnetic field/disturbance and exothermic reactions.
Preventive measures	The End User shall assure that actuator and its components are installed far from magnetic field, electro-magnetic field, radioactive source, electroacoustic transducer which could modify its behaviour. (This mitigation is applicable only for actuators provided with control panel) Avoid maintenance operations with acid/basic solutions.

4.7 Electrostatic Risks

Risk	Non-conductive parts of the equipment can build an electrostatic charge which is dangerous in hazardous areas.
Preventive measure	Do not polish/rub surfaces with a dry cloth. Only clean equipment surfaces with a suitable wet anti-static cloth. Operators must wear suitable anti-static clothing and use tools that will not generate a static charge. The user must ensure the operating environment and any materials surrounding the actuator cannot lead to a reduction in the safe use of, or the protection afforded by, the actuator.

5. Labels and Nameplates

The following label is applied externally to the actuator:

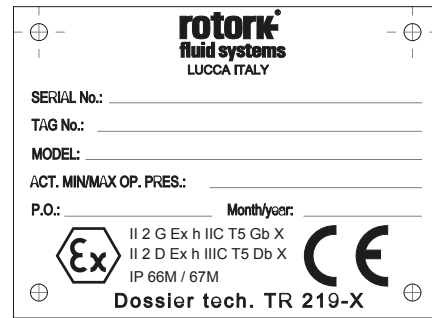

Fig 5.1 Actuator label

ATEX Type of Protection: constructional safety "c".

T5 temperature class is provided even if actuator has no internal heat source. Maximum actuator temperature is the environmental or exercise fluid temperature, whichever is the greater. Normal operating temperature range is -30 to +100 °C (-22 to +212 °F). Temperature range must be specified within the project specific technical documentation. Special applications beyond the standard temperature range are available upon request.

ATEX plate does not indicate the maximum environmental and/or exercise fluid temperature; this information is reported within the project specific technical documentation.

For CE (PED) marked actuator the following label is also used:

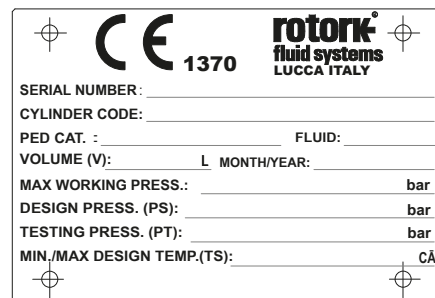

Fig 5.2 Actuator PED label

Label removal is not allowed.

6. Operating Limits

Temperature: -30 to +100 °C (-22 to +212 °F) for standard applications
-20 to +100 °C (-4 to +212 °F) for PED applications
-40 to +100 °C (-40 to +212 °F) for low temperatures
-60 to +100 °C (-76 to +212 °F) for ultra-low temperatures

Design pressure: up to 250 Barg, refer to job documentation.

Operating pressure: refer to job documentation.

⚠ Do not use the equipment outside its operating limits. Verify operating limits on the nameplate.

Prevent external surface temperature to reach the ignition point in potentially explosive environments.

The actuator surface temperature is strictly dependent on the temperature of the process fluid used and by the irradiation's conditions. The end-user must check the surface temperature of the assembly, so that this cannot go over the minimum gas ignition's temperature, which classifies the area with the explosion's risk.

Dust and debris accumulated on the actuator will slow down its cooling and contribute to the increase of its external temperature.

6.1 Allowed Fluid Types

RH actuators are designed to be operated with hydraulic oil ISO 4406 class 16/14/11.

⚠ Do not use the actuator in presence of naked flames.

6.2 Expected Lifetime

Expected Lifetime greater than 25 years, in normal service conditions and with planned maintenance.

6.3 Tightening Torque Chart

RECOMMENDED TIGHTENING TORQUE (Class 8.8 bolts)		
Bolt Size	Nm	Ft. Lbs
M6	8.5	6
M8	20	15
M10	40	30
M12	55	40
M14	110	81
M16	220	162
M20	430	317
M22	425	313
M24	585	431
M27	785	579
M30	1250	921
M33	1400	1030
M36	1750	1290
M48	5000	3688
M64	9200	6786

7. Handling and Lifting

⚠ Only trained and experienced personnel should handle/lift the actuator.

The actuator is supplied packed on pallets suitable for normal handling.

⚠ Handle the actuator with care. Never stack pallets.

7.1 Lifting Recommendations

- The lifting device and the sling must be suitably rated for the actuator weight and dimensions
- Do not use damaged sling(s)
- The sling must not be shortened with knots or bolts or any other makeshift device
- For lifting purposes, use only suitable lifting tools
- Do not drill holes, weld eye bolts or add any other type of lifting device on the actuator external surface
- Do not lift the actuator and valve combination with the actuator lifting lugs
- Every assembly must be estimated separately for a safe and correct lifting
- Avoid pulls or abrupt movements during lifting. Avoid pushing the load
- During lifting operations, do not handle the slings and/or the actuator

⚠ Do not step underneath suspended load.

7.2 Lifting Instructions

Note: Indication of Weight, Centre of gravity, lifting points are reported within specific project documentation.

For non-horizontal actuator orientation, please consult project specific documentation before lifting.

- Prior to lifting the actuator, remove electrical power and vent all pressure vessels (if present).
- For single-acting actuators, use slings as shown in Fig 7.1.
- For double-acting actuators, hook a double chain sling on the lifting lug on the Hydraulic cylinder and a textile sling on the centre body closure flange as shown in Fig 7.2.

⚠ The actuator must remain horizontal; balance the load.

- Angle β must be between 0° and 45° as shown below.

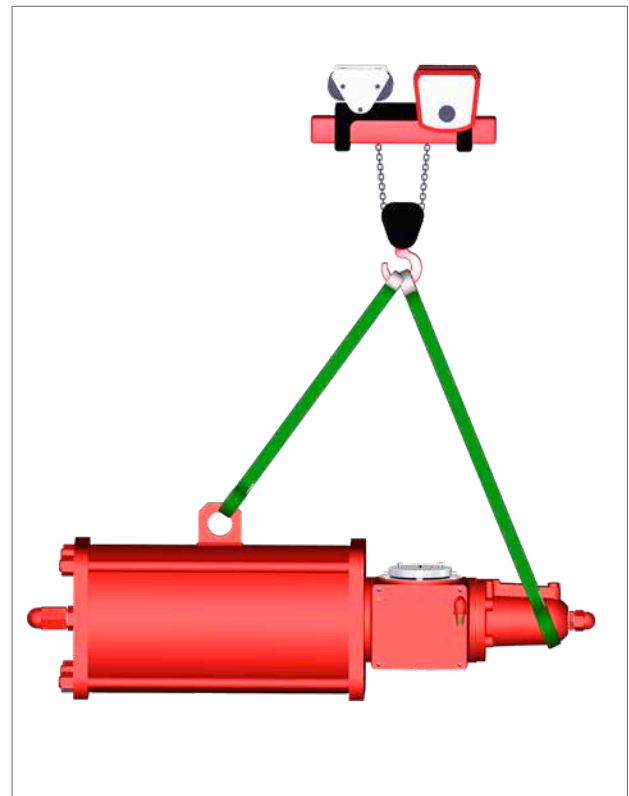
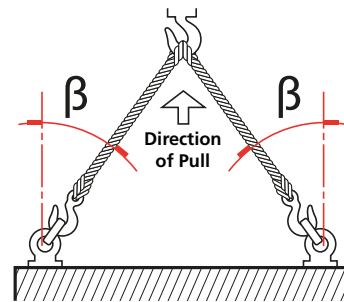

Fig 7.1 Lifting single-acting RH body sizes 015, 030, 060, 120, 240.

7. Handling and Lifting



Fig 7.2 Lifting double-acting RH body sizes 015, 030, 060, 120, 240.



Fig 7.3 Lifting double-acting RH body sizes 090, 105, 125, 145, 155, 185, 225, 250, 280.

8. Storage

Rotork actuators have been fully tested before leaving the factory.

Actuators must be kept in good condition until installation. Follow the measures below:

- Check presence and assembling of dust plugs
- Keep the actuator on shipping pallet until installation

Never put the actuator directly on the ground.

- Actuator must be positioned with the centre body cover upwards
- Protect the valve coupling area (adapter flange and coupling joint, etc.) with rust preventive oil e.g. Mobilarma LT or equivalent
- Protect against weather, cover the actuators with appropriate polyethylene sheets
- Check the actuator condition every 6 months and verify the above protection measures remain in place

Remove package only at the installation time.

Actuator vent ports must be protected with polyethylene sheet to prevent water ingress during storage.

9. Long Term Storage

If long term storage is necessary, further operations must be carried out to maintain the actuator in a good working condition:

- Replace the plastic plugs with metal plugs
- Stroke the actuator every 12-months
- Cycle the actuator with a hydraulic supply to the working pressure indicated on the name plate
 - Cycle the actuator with all the existing controls (i.e. two complete strokes - one open, one closed) at least 5 times
 - Cycle the actuator fitted with hydraulic manual override by means of the override for 4 complete strokes
 - Disconnect the hydraulic and electric (if present) supply from the actuator, and carefully close all the threaded connections of the actuator
- Remove electrical components covers (if present) to ensure control terminals are clean and free from oxidation and humidity. Reassemble the covers
- In case of storage for over 12 months prior to installation, it is recommended to operate the actuator to verify correct operation

10. Installation on Valve

Before proceeding, read and understand the Health and Safety information.

Note: Prior to performing the following operations, the valve must be properly secured per Valve Manufacturer instructions.

⚠️ Prior to performing any operations check the operating drawings and TAG numbers.

Consult Rotork for any additional information.

10.1 Preliminary Actions

⚠️ Verify the ATEX classification of the actuator is compatible with the plant zoning. Refer to actuator nameplate.

- The centreline of the cylinder is usually aligned to the centreline of the associated pipe work
- Ensure all fasteners are adequately tightened, to avoid loosening during operation, considering the vibrations induced by the dynamics of the pipeline
- Piping used to provide power to the actuator must be free from contaminants and debris. Ensure tubing runs are adequately fastened and supported to minimise repetitive stress induced the dynamics of the pipeline. Ensure there are no leaks from any gas connections. Tighten as required

10.2 Instructions

The actuator assembly on valve can be performed by:

- Mounting directly using the actuator housing flange with threaded holes
- Using an adapter and a coupling joint between the actuator and the valve

The assembly position of the actuator must be in accordance with the actuator design, plant requirements and the valve model.

To assemble the actuator onto the valve, proceed as follows:

- Verify the coupling dimensions of the valve flange and stem; they must meet the actuator coupling dimensions (See document pub019-001)
- Actuator is supplied in the fail position (for single-acting). Set the valve in the right position per the actuator fail position. Check the position of the actuator by means of the position indicator on the centre body or on the limit switch box (if present)
- Clean the coupling flange of the valve and remove anything that might prevent adherence to the actuator flange. Grease shall be completely removed
- Inspect, clean and apply grease on the coupling hole (valve side of coupling joint)

- Lubricate the valve stem with oil or grease, to facilitate assembling
- Lift the actuator according to Handling and Lifting instructions (section 7)
- If possible, place the valve stem in a vertical position to facilitate assembling - in this case the actuator must be lifted while the coupling flange is kept in the horizontal position
- If the assembly is done using an adapter and a coupling joint, assemble the coupling joint onto the valve stem before proceeding with the assembly of the actuator
- Do not exert any force while lowering the actuator onto the valve

Installation must be performed by qualified personnel.

⚠️ Keep hands away from the coupling area.

- Secure the actuator to the valve by means of threaded fixings (bolts, stud bolts and nuts)
- Tighten bolts or nuts of the connecting stud bolts to the correct torque, in accordance with the size and material characteristics of the bolts installed

⚠️ Support the actuator until fully installed and fixing bolts are correctly tightened.

⚠️ Attention: Do not pressurise the actuator/valve adapter.

- Check for possible damage to the paint-work and repair if necessary, per painting specification

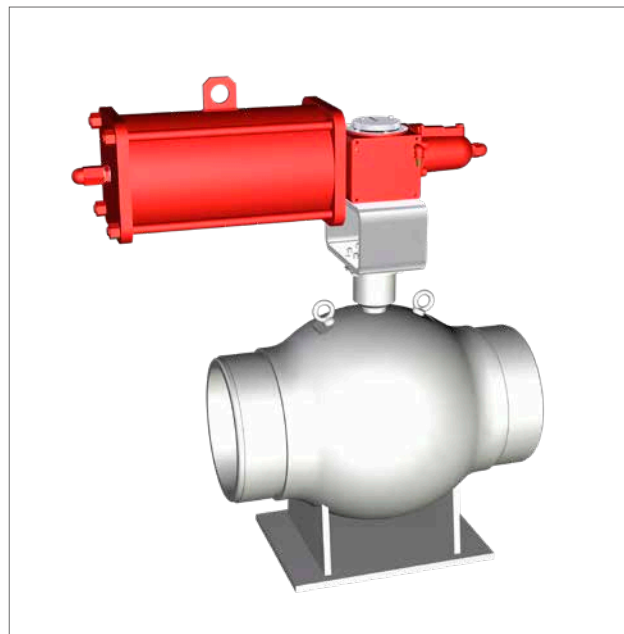

Fig 10.4 Actuator and valve assembly

10. Installation on Valve



Fig 10.5 Actuator and valve assembly



Fig 10.6 Actuator and valve assembly

11. Removal from Valve

The End user oversees removing the actuator from the valve.

⚠ Removal shall be performed only by qualified staff, wearing/using appropriate personal protection equipment.

⚠ Do not remove the actuator if the valve is blocked in the intermediate position. Contact Rotork customer service.

To disassemble the actuator from the valve, proceed as follows:

- Isolate electrical power supply
- Isolate hydraulic supply
- Release any pressure from the control group
- Remove the supply pipes from the actuator
- Remove control and signal lines from electric components (if any)
- Sling the actuator in line with Handling and Lifting instructions (section 7)
- Unscrew fixings between the actuator and the valve
- Lift and remove the actuator from the valve

12. Operation

The following instructions must be integrated into the user safety program when installing and using Rotork products. Read and save all instructions prior to installing, operating and servicing this product.

Follow all warnings, cautions and instructions marked on and supplied with the product.

Install equipment as specified in Rotork installation instructions and as per applicable local and national codes of practice. Connect all products to the proper pipeline gas sources.

When replacement parts are required, ensure that the qualified service technician uses only replacement parts specified by Rotork.

Substitutions will invalidate any hazardous area certification and may result in fire, electrical shock, other hazards or improper operation.

12.1 Description

RH/S actuators are hydraulic single-acting – spring return actuators specifically designed to provide efficiency and reliability in heavy duty services.

RH/S actuators can be assembled in a ‘spring to open’ or ‘spring to close’ configuration and can include an emergency manual override suitable to operate the actuator in the event of fluid supply failure.

Main components of an **RH/S actuator** (body sizes 015, 030, 060, 120, 240) are:

- A **Rack and pinion mechanism** (single rack), which transforms the linear movement of the hydraulic cylinder into a rotary movement suitable for operating quarter turn valves, such as ball valves, butterfly valves or plug valves.
The rack and pinion mechanism is situated in a perfectly sealed cast iron housing, providing protection against corrosion and ensuring safety of personnel during operation.
- A **hydraulic cylinder**, made of Ductile Iron.
The dynamic floating piston seal reduces friction and avoids stick-slip effect even after prolonged periods without operation. The PTFE sliding ring guides the piston in the cylinder and ensures a good radial loading capacity.
- The **spring cartridge** (single-acting actuators), consisting of a container for assembled spring package that prohibits over extension of the spring.
- Two mechanical **stop bolts** to enable adjustment of valve angular stroke.
- A **mechanical visual position indicator** directly connected to the valve stem that shows position of the valve through full actuator stroke.

Upon request, RH/S actuators can be equipped with additional accessories (limit switches box, positioner, position transmitter, control panel, etc.).

Use only control devices supplied by Rotork.

⚠ Installation of any accessory on the bare actuator must preserve the actuator Ingress Protection level.

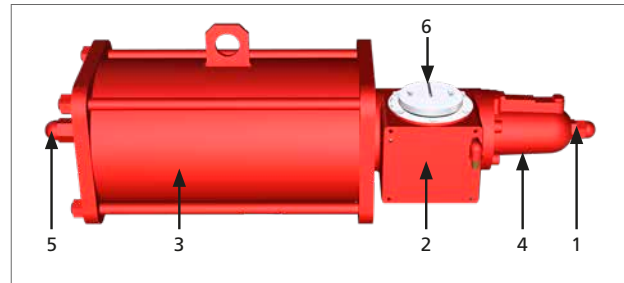

Fig 12.7 RH/S single-acting (body sizes 015, 030, 060, 120, 240) main components

Table 1: RH single-acting Parts list

IT	DESCRIPTION	QTY
1	Mechanical stop bolt	1
2	Centre body	1
3	Spring cartridge	1
4	Hydraulic cylinder	1
5	Mechanical stop bolt	1
6	Mechanical Visual Indicator	1

RH/D actuators are hydraulic double-acting actuators specifically designed to provide efficiency and reliability in heavy duty services:

- RH/D2 (body sizes 015, 030, 060, 120, 240) have two hydraulic cylinders
- RH/D4 (body sizes 090, 105, 125, 145, 155, 185, 225, 250, 280) have four hydraulic cylinders for extremely high torque output

Actuator general features are the same as the single-acting version, except the spring canister is replaced by the centre body closure group.

Main components of an RH/D2 (body sizes 015, 030, 060, 120, 240) actuator are:

- A **Rack and pinion mechanism** (single rack), which transforms the linear movement of the hydraulic cylinder into a rotary movement suitable for operating quarter turn valves, such as ball valves, butterfly valves or plug valves.

The rack and pinion mechanism is situated in a perfectly sealed cast iron housing, providing protection against corrosion and ensuring safety of personnel during operation.

12. Operation

- Two **hydraulic cylinders**, made of Ductile Iron.
The dynamic floating piston seal reduces friction and avoids stick-slip effect even after prolonged periods without operation. The PTFE sliding ring guides the piston in the cylinder and ensure a good radial loading capacity.
- Two mechanical **stop bolts** to enable adjustment of valve angular stroke.
- A **mechanical visual position indicator** directly connected to the valve stem that shows position of the valve through full actuator stroke.

Upon request, RH/D2 actuators can be equipped with additional accessories (limit switches box, positioner, position transmitter, control panel, etc.).

Only use control devices supplied by Rotork.

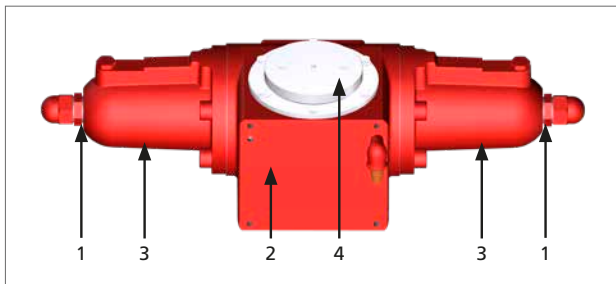

Fig 12.8 RH/D2 double-acting (body sizes 015, 030, 060, 120, 240) main components

Table 2: RH double-acting (2 cylinders) parts list

IT	DESCRIPTION	QTY
1	Mechanical stop bolt	2
2	Centre body	1
3	Hydraulic cylinder	2
4	Mechanical Visual Indicator	1

Main components of a RH/D4 (body sizes 090, 105, 125, 145, 155, 185, 225, 250, 280) actuator are:

- A **Rack and pinion mechanism** (double rack), which transforms the linear movement of the hydraulic cylinder into a rotary movement suitable for operating quarter turn valves, such as ball valves, butterfly valves or plug valves.

The rack and pinion mechanism is situated in a perfectly sealed carbon steel housing, providing protection against corrosion and ensuring safety of personnel during operation.

- Four **hydraulic cylinders**, made of carbon steel.
The dynamic floating piston seal reduces friction and avoids stick-slip effect even after prolonged periods without operation. The PTFE sliding ring guides the piston in the cylinder and ensure a good radial loading capacity.
- Four mechanical **stop bolts** to enable the adjustment of valve angular stroke.

- A **mechanical visual position indicator** directly connected to the valve stem that shows the position of the valve through full actuator stroke.

Upon request, RH/D4 actuators can be equipped with additional accessories (limit switches box, positioner, position transmitter, control panel, etc.).

Only use control devices supplied by Rotork.

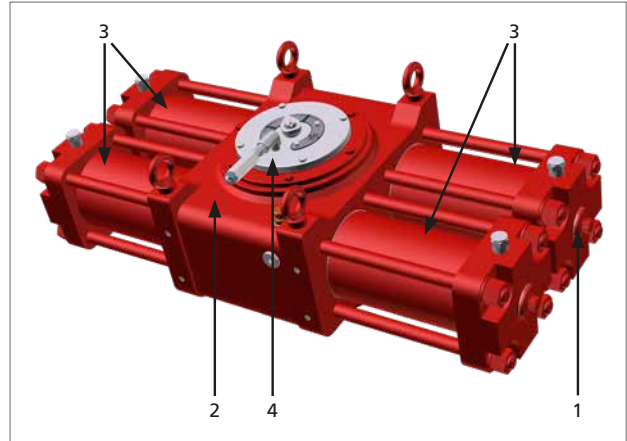

Fig 12.9 RH/D4 double-acting (body sizes 090, 105, 125, 145, 155, 185, 225, 250, 280) main components

Table 3: RH double-acting (4 cylinders) parts list

IT	DESCRIPTION	QTY
1	Mechanical stop bolt	4
2	Centre body	1
3	Hydraulic cylinder	4
4	Mechanical Visual Indicator	1

12. Operation

12.2 Operating Description

Please refer to the Operating Diagram supplied for the specific actuator.

Where RH actuators are used in SIL applications the System Integrator must fulfil all requirements reported in par. 11.2.11 of standard IEC61511-1.

⚠ Do not use the actuator beyond 85° - 95° operating range.

12.3 Actuator Code and Design

Actuator build code shown below:

Example Model Number	R	H	- 060 -	045	F /	C1 -	HPB
ACTUATOR TYPE R = Rack and Pinion							
SUPPLY TYPE H = Hydraulic							
CENTRE BODY SIZE 015, 030, 060, 090, 105, 120, 125, 145, 155, 185, 225, 240, 250, 280							
CYLINDER SIZE							
TEMPERATURE F = Standard G = High H = Low L = Extreme low							
CYLINDER / SPRING CANISTER CONFIGURATION C0 ÷ C9 = Spring-Return Fail Close - Spring set # 0-9 O0 ÷ O9 = Spring-Return Fail Open - Spring set # 0-9 D2 = Double-Acting - Two Cylinders D4 = Double-Acting - Four Cylinders (only with body sizes 090, 105, 125, 145, 155, 185, 225, 250, 280)							
MANUAL OVERRIDE TYPE HPB, HPC (not applicable for D4)							

Body sizes 015, 030, 060, 120, 240 are available in both single and double-acting configuration, max torque 3,400 Nm (2,508 lbf.ft).

Body sizes 090, 105, 125, 145, 155, 185, 225, 250, 280 are available in double-acting configuration only, max torque 700,000 Nm (516,293 lbf.ft).

12.4 Manual Override

RH/S and RH/D2 (body sizes 015, 030, 060, 120, 240) can be fitted with an emergency manual override to operate the actuator in the event of fluid supply failure.

This device is of hydraulic type, using a hydraulic hand pump.

⚠ A maximum operating time of the manual override of 24 hours, for maintenance or testing, is recommended.

Note: The use of manual override is not recommended in SIL applications. If it is necessary, strictly follow instructions reported in the following paragraphs.

⚠ Before operating the manual override, ensure that the cylinder is not pressurised and that the actuator is in the fail position.

For installation and operation procedures for the hydraulic manual override, refer to PUB016-004-00.

For RH/S with hydraulic HPB override, refer to section 5 of PUB016-004-00.

For RH/D with hydraulic HPC override, refer to section 4 of PUB016-004-00.

The drawings shown in this manual refer to a single hydraulic cylinder supplied from both the left and right side of the piston. A RH/D has two independent cylinders/pistons, one supplied to the right side, the other supplied to left side.

⚠ After each use, verify that the manual override is disengaged.

Due to the extremely high torque output, no manual override is available for RH/D4.

12.5 Angular Stroke Setting

⚠ Certain valves incorporate their own travel stops. Rotork recommend the actuator stop bolt positions match the valve stop positions.

Contact the valve manufacturer to adjust the valve mechanical stops.

⚠ An incorrect setting of angular stroke could cause damage to the actuator, valve and/or personnel.

12. Operation

12.5.1 Single-acting actuator RH/S (body sizes 015, 030, 060, 120, 240), cylinder stop bolt setting

Set the cylinder stop bolt first. Where shown, tools may be required.

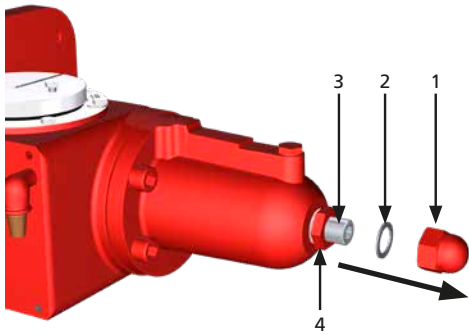

Adjust the stop bolt in the end flange of the cylinder as follows:

- A. Verify the absence of pressure
- B. Remove cap nut (1) and seal washer (2)
- C. Loosen stop nut (4)
- D. Slowly pressurise the cylinder to detach the stop bolt (3) from the piston

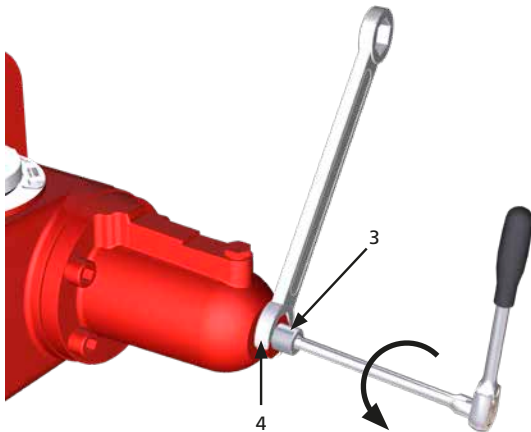

- E. Hold the stop nut (4)
- F. Rotate the stop bolt (3) to adjust stroke. Clockwise will decrease angular stroke, anti-clockwise will increase angular stroke
- G. Depressurise the cylinder
- H. Verify the new position with one operating stroke
- I. Repeat operations D to G, until the desired angle is obtained

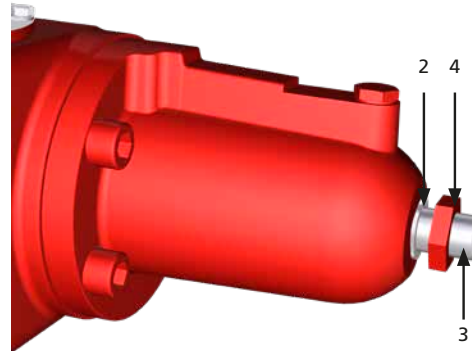

- J. Re-position the seal washer (2) between the cylinder and the stop nut (4)

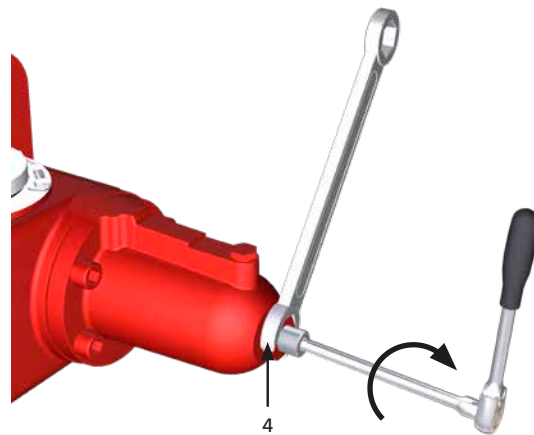

- K. Hold the stop bolt (3) and carefully tighten the stop nut (4)

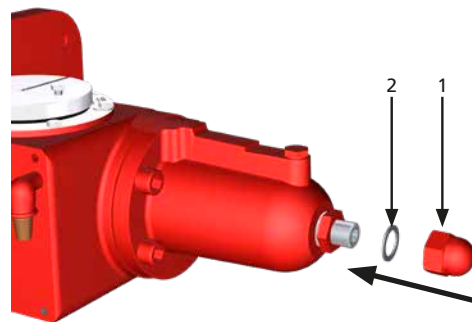

- L. Reinstall the seal washer (2) and cap nut (1)

12. Operation

12.5.2 Single-acting actuator RH/S (body sizes 015, 030, 060, 120, 240), spring cartridge stop bolt setting

Where shown, tools may be required.

Adjust the stop bolt in the spring cartridge as follows:

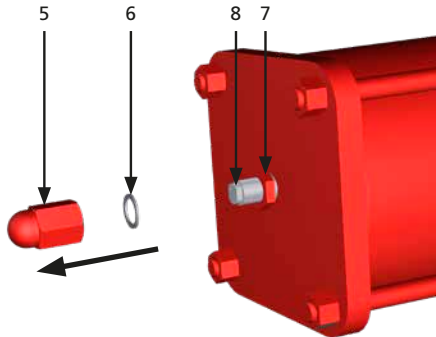

- A. Pressurise the cylinder to the open/close position and verify the actuator stroke stop
- B. Depressurise the cylinder to adjust the angular stroke setting

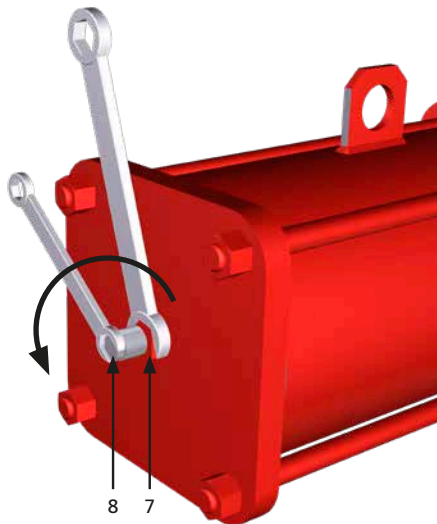

- C. Remove protection plug (5) and seal washer (6)
- D. Hold stop bolt (8) and loosen stop nut (7)
- E. Hold the stop nut (7)
- F. Rotate the stop bolt (8) to adjust stroke. Clockwise will decrease angular stroke, anti-clockwise will increase angular stroke
- G. Verify the new position with one operating stroke
- H. Repeat operations E to G until the desired angle is obtained

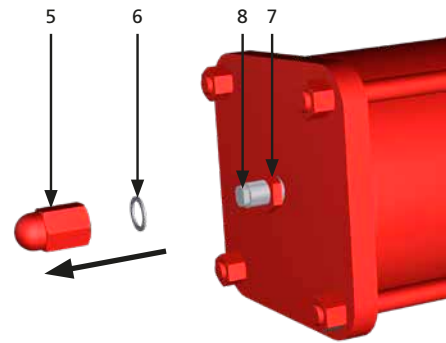

- I. Hold the stop bolt (8) and carefully tighten the stop nut (7)
- J. Reinstall the seal washer (6) and protection plug (5)

12.5.3 Double-acting actuator RH/D2 (body sizes 015, 030, 060, 120, 240), cylinder stop bolt setting

Set the cylinder stop bolt first.

Instructions assume operating direction is in accordance with conventions detailed in ISO 5211. Clockwise to close and anticlockwise to open.

Set stop bolts of cylinder X1 for the close position. Set stop bolts of cylinder X2 for the open position.

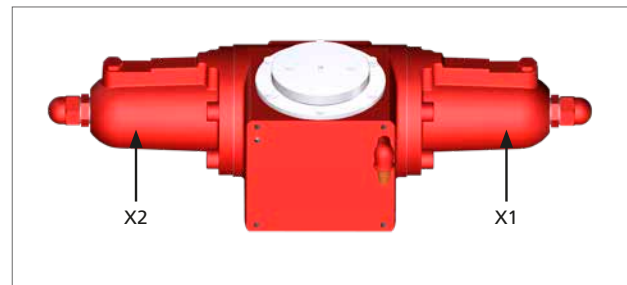

Fig 12.10 RH/D2 (body sizes 015, 030, 060, 120, 240) cylinder identification.

Adjustment of the stop bolts on cylinder X1 and cylinder X2 is the same as adjusting the stop bolts on a single-acting actuator RH/S. Refer to the single-acting actuator RH/S cylinder stop bolt procedure described earlier in this manual.

12. Operation

12.5.4 Double-acting actuator RH/D4 (body sizes 090, 105, 125, 145, 155, 185, 225, 250, 280), cylinder stop bolt setting

Set the cylinder stop bolts first.

Instructions assume operating direction is in accordance with conventions detailed in ISO 5211. Clockwise to close and anticlockwise to open.

Set stop bolts of cylinder X1 and cylinder X3 for the close position.

Set stop bolts of cylinder X2 and cylinder X4 for the open position.

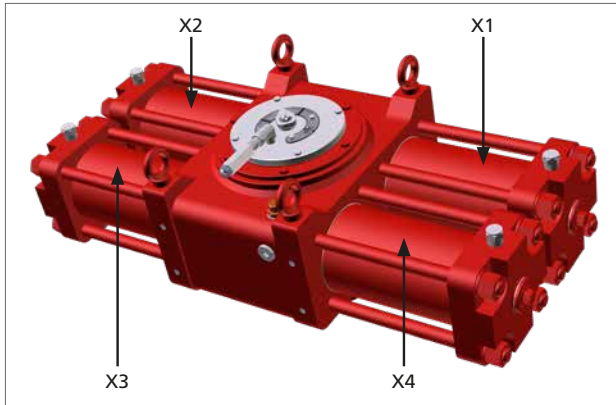
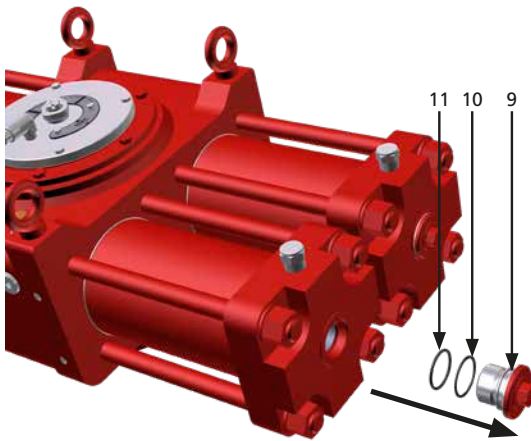
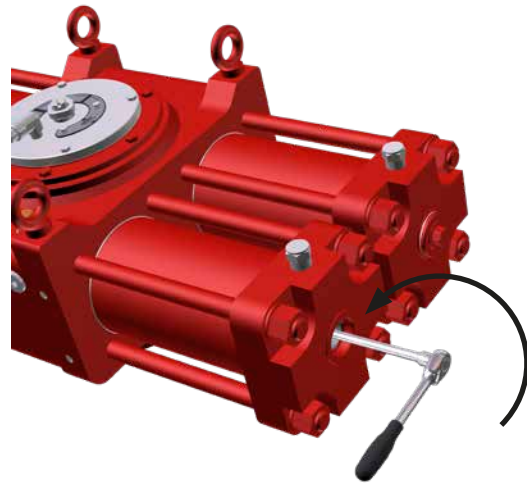

Fig 12.11 RH/D4 (body sizes 090, 105, 125, 145, 155, 185, 225, 250, 280) cylinder identification.

Adjust the stop bolts located in the end flange of each cylinder:



- Verify the absence of pressure
- Remove cap nut (9) and O-rings (10 and 11)
- Slowly pressurise the cylinder to detach the stop bolt (12) from the piston



- Rotate the stop bolt (12) to adjust stroke. Clockwise will decrease angular stroke, anti-clockwise will increase angular stroke
- Depressurise the cylinders
- Verify the new position with one operating stroke
- Repeat operations D to F, until the desired angle is obtained

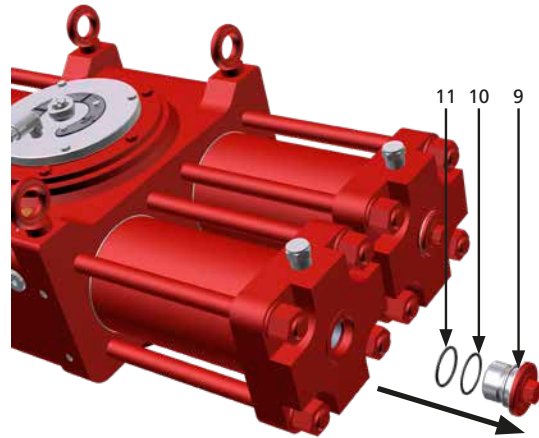

- Replace the O-rings (10, 11) and the cap nut (9)

All four cylinders must be set before operating the actuator in normal service conditions. Always adjust the close (X1 and X3) or open (X2 and X4) stop bolts together to ensure contact is equal on both stop bolts.

12. Operation

12.6 Hydraulic Power Supply

Check the supply pressure range on actuator label.

⚠️ Verify medium composition. Contact Rotork to check the compatibility with the supply medium.

12.7 Hydraulic Connections

Preliminary Operations

- Confirm the size of pipes and fittings per applicable plant specifications
- Clean the inside of the connection pipes by washing them with a suitable detergent and blowing air into them
- The connecting pipes must be properly shaped and secured to prevent stress or loosening of threaded connections

Note: For tapered-thread fluid connections, apply a thin layer of thread sealing product (Loctite 577 or equivalent) to ensure a good seal.

⚠️ Connect the Hydraulic power source in accordance to the applicable operating diagram, refer to specific job for details.

⚠️ Hydraulically powered actuators may exhaust the power supply gas into the atmosphere during normal operation. This may present an unacceptable hazard.

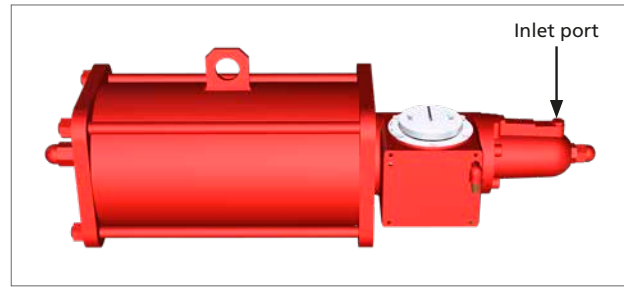

Fig 12.12 Inlet port for single-acting actuator RHIS (body sizes 015, 030, 060, 120, 240)

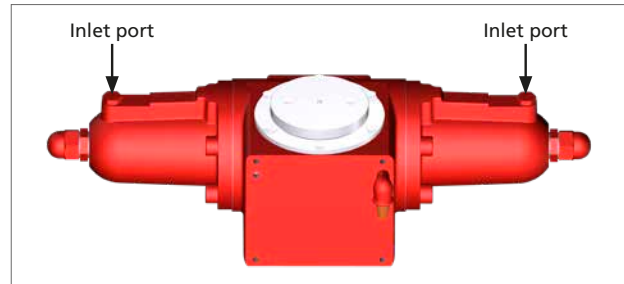

Fig 12.13 Inlet port for double-acting actuator RHID2 (body sizes 015, 030, 060, 120, 240)

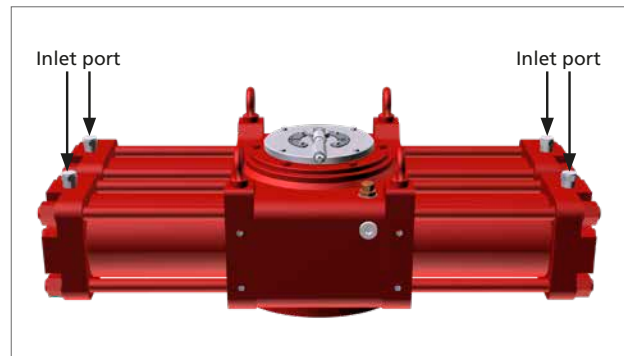



Fig 12.14 Inlet port for double-acting actuator RHID4 (body sizes 090, 105, 125, 145, 155, 185, 225, 250, 280)

12. Operation

12.8 Electrical Connections

 **Check supply voltage of electrical components.**

 **Access to live electrical conductors is forbidden in hazardous areas unless done under a special permit. All power must be isolated and the unit moved to a non-hazardous area for repair.**

 **Prevent electrostatic charges in potentially explosive areas.**

Electrical connection can be performed as follows:

- Isolate the power supply
- Remove plastic cable entry protection plugs
- Only use appropriately certified reduction fittings, cable glands, fittings and explosion-proof cables
- The cable glands must be tightened in the threaded inlets, to guarantee the waterproof and explosion proof protection
- O-rings must be correctly installed on the cable glands to prevent water and debris infiltration inside electric components
- The size of the electric supply cable must be suitable for the electric power demand
- Insert the connection cables through cable glands and perform assembly per the cable gland manufacturer's instructions
- Connect the cable wires to the terminal block as per the applicable wiring diagram
- Electric connections must be made by using rigid conduits and trailing cables to prevent mechanical stresses in the cable entries
- Any unused conduit entries must have the plastic plugs replaced with approved metal plugs to comply with explosion safety protection codes
- Assemble electric enclosure covers with appropriate seals
- Always check electrical component functionality after commissioning

 **The actuator and electrical components must be protected from electrical sparks, lightning, magnetic or electro-magnetic fields.**

12.9 Start Up

Check the following during start-up of the actuator:

- Medium supply pressure is correct
- The supply voltage for electrical components (solenoid valves coils, limit switches, pressure switches etc.) is correct
- All actuator controls (remote control, local control, emergency control, etc.) work correctly
- Remote signals are correct
- The control unit meets plant requirements
- Hydraulic connections show no leakage
- The painted parts have not been damaged during transport, assembly or storage. Repair the damaged parts following applicable painting specifications
- Actuator and connected parts work as expected
- Operating time meets requirements

 **The user must provide appropriate grounding and ensure equal voltage potential between the valve and actuator. The user shall indicate and maintain grounding connections on the actuator.**

13. Dismantling and Disposal

The actuator and all connected components must be depressurised before dismantling can begin.

For single-acting actuators.

 The spring cartridge module contains a compressed spring. After removing the spring cartridge from the centre body, the spring cartridge must be returned to Rotork.

 Grease and oil must be disposed of safely in accordance with local environmental laws and regulations.

- Dismount the actuator and separate the various parts per the type of material
- Dispose of the pieces of steel, cast iron and aluminium alloys as metal scraps
- Dispose of the rubber, PVC, resins etc. separately, in accordance with existing national and regional regulations
- Electric components are to be separately disposed of on specialised disposal sites

14. Rotork Sales and Service

Should you require technical assistance or spares, Rotork guarantees the best service in the world. Contact your local Rotork representative or the factory direct at the address on the nameplate, quoting the actuator type and serial number. Some actuators have a special spare parts list. Refer to the project specific documentation for further details.

15. Troubleshooting

ID	FAILURE	POSSIBLE CAUSES	CORRECTIVE MEASURES
1	Incorrect valve position	<ul style="list-style-type: none"> Fault of pipeline valve 	<ul style="list-style-type: none"> Consult the valve manufacturer's documentation
2	Incorrect indication of valve position	<ul style="list-style-type: none"> Incorrect signal from limit switches 	<ul style="list-style-type: none"> Check limit switches position (according instructions reported in the job specific documentation)
3	Incorrect movement	<ul style="list-style-type: none"> Irregular supply of operating medium 	<ul style="list-style-type: none"> Verify the supply pressure and adjust as necessary
		<ul style="list-style-type: none"> Worn parts 	<ul style="list-style-type: none"> Contact Rotork customer service
		<ul style="list-style-type: none"> Fault in control panel equipment (if present) 	<ul style="list-style-type: none"> Contact Rotork customer service
		<ul style="list-style-type: none"> Fault of pipeline valve 	<ul style="list-style-type: none"> Consult the valve manufacturer's documentation
4	Valve stroke not fully completed	<ul style="list-style-type: none"> Insufficient fluid flow 	<ul style="list-style-type: none"> Increase fluid supply flow
		<ul style="list-style-type: none"> Incorrect assembly between actuator and valve 	<ul style="list-style-type: none"> Perform assembly according to Installation on Valve (section 10)
		<ul style="list-style-type: none"> Valve blocked 	<ul style="list-style-type: none"> Consult the valve manufacturer's documentation
		<ul style="list-style-type: none"> Stop bolts wrong setting 	<ul style="list-style-type: none"> Adjust stop bolt setting following instructions in Angular Stroke Setting (section 12.5)
5	Leakages	<ul style="list-style-type: none"> Stop bolts wrong setting 	<ul style="list-style-type: none"> Adjust stop bolt setting following instructions in Angular Stroke Setting (section 12.5)
		<ul style="list-style-type: none"> Worn seals 	<ul style="list-style-type: none"> Replace seals per instructions PM-RH-006 or PM-RH-007 (section 16)
6	Actuator moves too fast	<ul style="list-style-type: none"> No pressure on pipeline 	<ul style="list-style-type: none"> Restore pipeline pressure
		<ul style="list-style-type: none"> Supply pressure greater than allowed range values 	<ul style="list-style-type: none"> Verify the supply pressure and adjust as necessary
7	Actuator moves too slow	<ul style="list-style-type: none"> Fault on pipeline valve (valve hardened) 	<ul style="list-style-type: none"> Consult the valve manufacturer's documentation
		<ul style="list-style-type: none"> Supply pressure lower than allowed range values 	<ul style="list-style-type: none"> Verify the supply pressure and adjust as necessary
		<ul style="list-style-type: none"> Possible internal undue friction 	<ul style="list-style-type: none"> Contact Rotork customer service
8	Loss of power	<ul style="list-style-type: none"> Inadequate supply pressure 	<ul style="list-style-type: none"> Ensure that the supply pressure is above the minimum operating pressure of the actuator and that the output torque produced at supply pressure exceeds the required valve torque.
		<ul style="list-style-type: none"> Leakage from cylinder 	<ul style="list-style-type: none"> Replace seals according instructions reported in PM-RH-006 or PM-RH-007 (section 16)

For other problems, please contact Rotork.

16. Periodic Maintenance

Rotork recommends performing the following checks to help comply with the rules and regulations of the country of final installation:

⚠ Remove pressure before proceeding with maintenance operations, discharge any accumulators or tanks (if present), except where otherwise indicated.

Periodic Maintenance Schedule



MAINTENANCE ACTIVITY	PERIODICITY		REFERENCE
	Months	Years	
Visual check of external components and control groups	6*	*	
Verify welding. In case of anomalies contact Rotork	6*	*	
Breather cleaning	6*	*	
Check Hydraulic connections for leaks. Tighten pipe fittings as required	-	1*	
Cleaning	-	1*	PM-RH-001
Visual check of painting. Verify absence of damages. Repair if necessary per painting specification	-	1*	
Functional test	-	1*	PM-RH-002
Functional Manual Override test	-	1*	PM-RH-003
Check electrical components (if present) and grounding connections	-	1*	PM-RH-004
Check threaded connections (bolts, studs and nuts) to the valve. Tighten to the recommended torque, in accordance with the size and the characteristics of the fastener material installed		1*	
Single-acting actuator RH/S hand pump oil replacement	-	5*	PM-RH-005a
Double-acting RH/D2 actuator hand pump oil replacement	-	5*	PM-RH-005b
Hydraulic Cylinder and centre body seal replacement RH/S and RH/D2 Actuator	-	5*	PM-RH-006
Hydraulic Cylinder and centre body seal replacement RH/D4 Actuator	-	5*	PM-RH-007

(*) The time between maintenance tasks will vary depending on the operating medium and service conditions. Refer to End User Plant Preventive Maintenance Program (if available from the end user) for specific task frequency.

For Functional Safety applications refer to Safety Manual (available upon request).

Specific maintenance may be necessary for specific applications. Refer to job documentation for applicable additional maintenance tasks.



16. Periodic Maintenance

PM-RH-001		Page: 1/1
Component: Single-acting actuator Double-acting actuator	Task: Cleaning	
Equipment, Tools, Materials: Air compressor Project documentation (Design and Operating pressure values) Damp Cloth	Warnings: 	
Preliminary Operations:		
Description:  Remove hydraulic power supply and electric power supply (if present) before proceeding. 1. Remove dust from actuator external surface with a damp cloth and pressurised air from an air compressor  Do not polish/rub non-metal surfaces with a dry cloth. The tools and cleaning procedures must not produce sparks or create adverse conditions in the environment during maintenance operations, to prevent potential explosion hazards. Prevent electrostatic charges in potentially explosive areas.		



16. Periodic Maintenance

		PM-RH-002	Page: 1/1
Component: Single-acting actuator Double-acting actuator		Task: Functional test	
Equipment, Tools, Materials: Chronometer Project documentation (required stroke times)		Warnings: 	
Preliminary Operations:			
Description:			
NOTE: Actuator must be connected to the hydraulic supply to perform the following test.			
<ol style="list-style-type: none"> 1. Operate the actuator 2. Perform a stroke several times by local and remote (if applicable) control 3. Verify actuator is correctly operating 4. Note the stroke time(s) 5. Verify stroke time(s) are as required 			
If stroke time is beyond the required range refer to Troubleshooting ID 4, 5 (section 15)			



16. Periodic Maintenance

PM-RH-003		Page: 1/1
Component: Mechanical Manual Override for RH/S and RH/D2 - body sizes 015, 030, 060, 120, 240	Task: Manual override functional test	
Equipment, Tools, Materials: Project documentation	Warnings: 	
Preliminary Operations:		
Description:		
Opening operation		
<ol style="list-style-type: none">1. Verify the absence of pressure2. Verify the actuator is in its fail position, spring relaxed (for single-acting actuator)3. Move the mechanical manual override per instructions in this manual to stroke the actuator4. Verify the actuator reaches the desired position		
 Before re-starting the actuator with hydraulic supply, disengage the manual override to set the actuator to its original position. After each use, verify the manual override has been disengaged before returning to remote operation.		

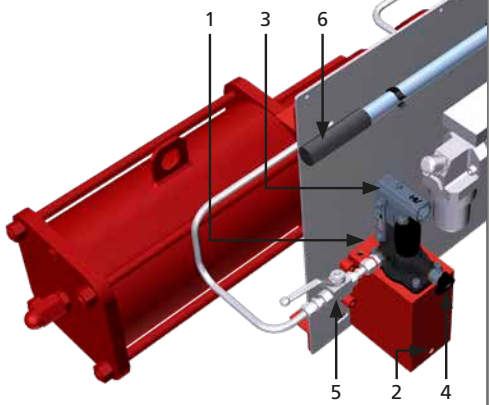

16. Periodic Maintenance

PM-RH-004		Page: 1/1
Component: Electrical components (if present)	Task: Check electrical components (if present) and grounding connections	
Equipment, Tools, Materials: Project documentation	Warnings: 	
Preliminary Operations:		
Description:		
<p> Isolate electric power supply before working on electrical devices. Read and follow the safety precautions in the component manufacturer's maintenance manual. Risk of temporary modification to component protection.</p> <p>Use only antistatic clothes.</p> <ol style="list-style-type: none"> 1. Remove cover from electric components 2. Check condition of electric device components 3. Verify tightness of terminal blocks 4. Verify absence of humidity and oxidation 5. Check cable gland seals 6. Verify grounding connection and restore if necessary 		

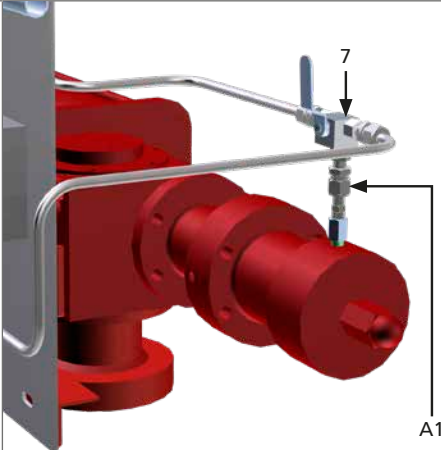

16. Periodic Maintenance

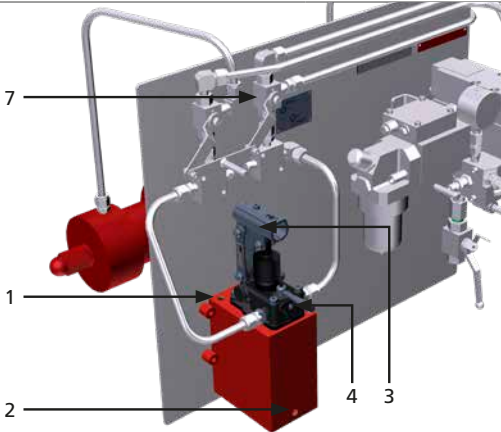
PM-RH-005a		Page: 1/1
Component: Hydraulic manual override for single-acting actuator RH/S – body sizes 015, 030, 060, 120, 240		Task: Single-acting actuator RH/S hand pump hydraulic oil replacement
Equipment, Tools, Materials: Project documentation Wrench		Warnings: 
Preliminary Operations:		
Description: Tasks must be executed with the tank in the vertical position and the actuator in the fail position. Verify the absence of Hydraulic pressure. The correct oil level is approximately 25 mm (1") below the fill/breather port.		
Drain procedure		
<ol style="list-style-type: none"> 1. Remove breather/plug (1) 2. Place containers under drain port (2) to collect the fluid 3. Remove plug (2) 4. Drain the oil 5. Tighten breather/plug (2) back in its seat with a wrench 		
 Used hydraulic fluid must be disposed of safely.		
Filling procedure		
<ol style="list-style-type: none"> 6. Fill with oil from the fill/breather port (1) up to 25 mm (1") below the port 7. Unfasten fitting (A1) 8. Close stop valve (4) and verify stop valve (5) is open 9. Switch local/remote selector (7) to the local position 10. Install the pump lever (6) and operate pump (3) until oil is bled from port A1 11. Tighten fitting (A1) with a wrench 12. Continue operating the pump to fully compress the actuator spring 13. Ensure the oil level in the tank does not drop below the intake tube 14. Keep the cylinder pressurised for 3 to 5 minutes, to settle the oil level 15. Slowly open stop valve (4) to allow the actuator the return to the fail position 16. Repeat the pump operation procedure 2 or 3 times. 17. Check the oil level. If necessary, fill in from the fill/breather port (1) 18. Reinstall the tank breather (1) and return the lever (6) to the storage holder 		

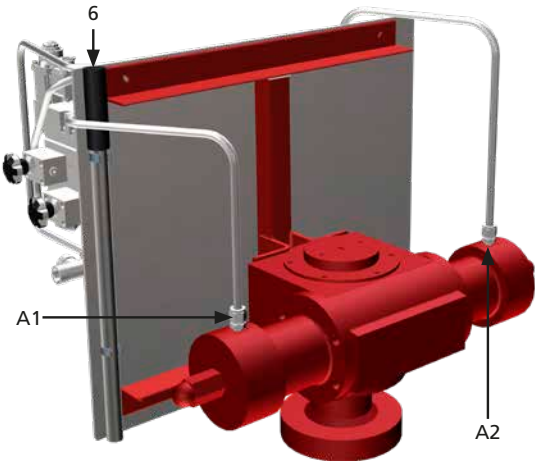
16. Periodic Maintenance

PM-RH-005b		Page: 1/1
Component: Hydraulic manual override for double-acting actuator RH/D2 – body sizes 015, 030, 060, 120, 240		Task: Double-acting actuator RH/D2 hand pump hydraulic oil replacement
Equipment, Tools, Materials: Project documentation Wrench		Warnings: 
Preliminary Operations:		
Description: Tasks must be executed with the tank in the vertical position and the actuator in the fail position. Verify the absence of hydraulic pressure. The correct oil level is approximately 25 mm (1") below the fill/breather port.		
Drain procedure		
<ol style="list-style-type: none"> 1. Remove breather/plug (1) 2. Place containers under drain port (2) to collect the fluid 3. Remove plug (2) 4. Drain the oil 5. Tighten breather/plug (2) back in its seat with a wrench 		
 Used hydraulic fluid must be disposed of safely.		
Filling procedure		
<ol style="list-style-type: none"> 6. Fill with oil from the fill/breather port (1) up to 25 mm (1") below the port 7. Switch local/remote selector (7) to local position 8. Unfasten fitting (A1) 9. Move the open/close selector (4) to the right 10. Install the pump lever (6) and operate pump (3) until oil is bled from port A1 11. Tighten fitting (A1) with a wrench 12. Continue operating the pump to the end of the actuator stroke 13. Ensure the oil level in the tank does not drop below the intake tube 14. Keep the cylinder pressurised for 3 to 5 minutes, to settle the oil level 15. Unfasten fitting (A2) 16. Move the open/close selector (4) to the left 17. Install the pump lever (6) and operate pump (3) until oil is bled from port A2 18. Tighten fitting (A2) with a wrench 19. Continue operating the pump to the end of the actuator stroke 20. Ensure the oil level in the tank does not drop below the intake tube 21. Keep the cylinder pressurised for 3 to 5 minutes, to settle the oil level 22. Repeat the pump operation procedure 2 or 3 times 23. Check the oil level. If necessary, fill in from the fill/breather port (1) 24. Reinstall the tank breather (1) and return the lever (6) to the storage holder 		

16. Periodic Maintenance

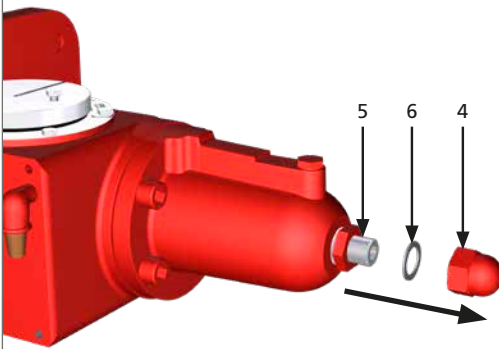
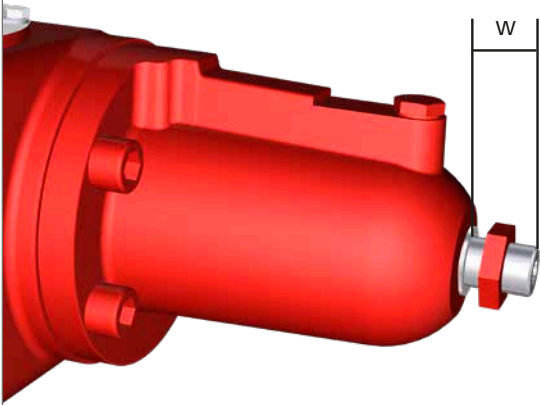
		PM-RH-006	Page: 1/10
Component: Single-acting actuator RH/S and double-acting actuator RH/D2 – body sizes 015, 030, 060, 120, 240		Task: Hydraulic cylinder and centre body seal replacement	
Equipment, Tools, Materials: Spare seals Wrench Lifting tools Project documentation		Warnings: 	
Preliminary Operations: Removal from Valve			
Description:  Isolate the hydraulic power supply and electric power supply (if present) before performing any operations. Adequate lifting devices suitable for the weight must be applied by skilled personnel.			
Preliminary actions			
<ol style="list-style-type: none"> 1. Verify actuator is in the fail position (single-acting) and not pressurised 2. Remove actuator from the valve 3. Position the actuator on a workbench (if possible) or in a stable position and in a clean and closed area 4. Remove any control equipment (if present). Refer to the project specific documentation 5. Remove hydraulic pipes 		<ol style="list-style-type: none"> 6. Hold stop nut (5) with a wrench, unscrew and remove cap nut (4) with seal washer (6) 	
<ol style="list-style-type: none"> 7. Measure length (W) 			

16. Periodic Maintenance

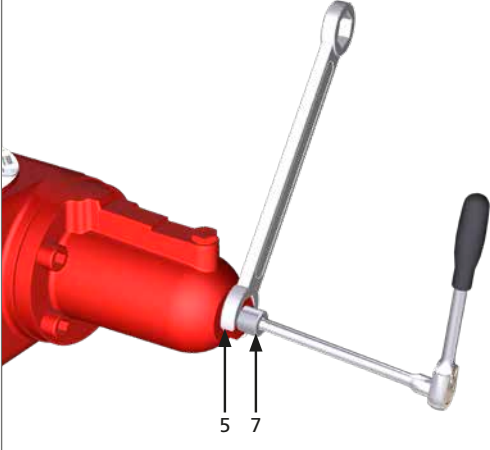
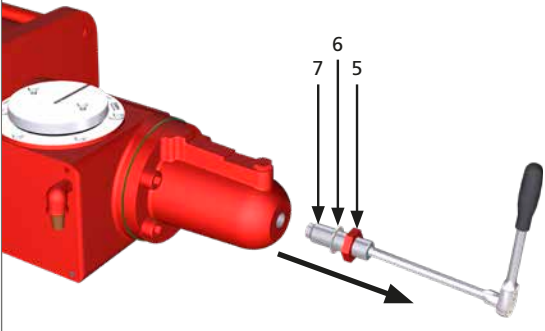
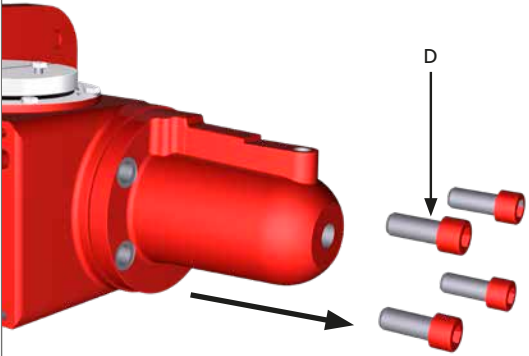
PM-RH-006		Page: 2/10
Component: Single-acting actuator RH/S and double-acting actuator RH/D2 – body sizes 015, 030, 060, 120, 240	Task: Hydraulic cylinder and centre body seal replacement	
Equipment, Tools, Materials: Spare seals Wrench Lifting tools Project documentation	Warnings: 	
Preliminary Operations: Removal from Valve		
8. Hold stop bolt (7) with an Allen (Hex.) Key and loosen stop nut (5)		
9. Fully unscrew stop bolt (7) 10. Remove seal washer (6) and stop nut (5) ⚠ Do not unscrew the stop bolt completely while the cylinder is pressurised		
11. Unscrew fixings (D) gradually, all at the same time to release the spring energy ⚠ The spring cartridge module can exert a thrust against the centre body.		

16. Periodic Maintenance

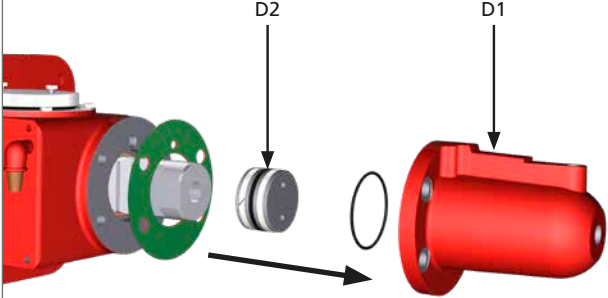
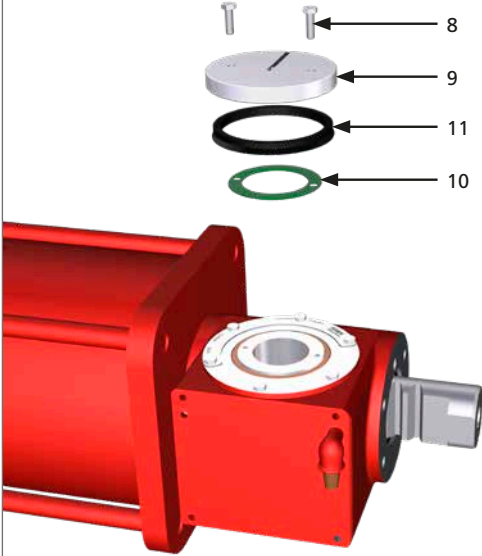
PM-RH-006		Page: 3/10
<p>Component: Single-acting actuator RH/S and double-acting actuator RH/D2 – body sizes 015, 030, 060, 120, 240</p>	<p>Task: Hydraulic cylinder and centre body seal replacement</p>	
<p>Equipment, Tools, Materials: Spare seals Wrench Lifting tools Project documentation</p>	<p>Warnings:</p> 	
<p>Preliminary Operations: Removal from Valve</p>		
<p>12. Remove cylinder (D1). 13. Remove gasket and O-ring (see specific part list) between spring container and centre body. 14. Remove piston from cylinder (D2)</p>		
<p>15. Unfasten screws (8) 16. Remove top flange (9) with gasket (10) and seal (11)</p>		

16. Periodic Maintenance

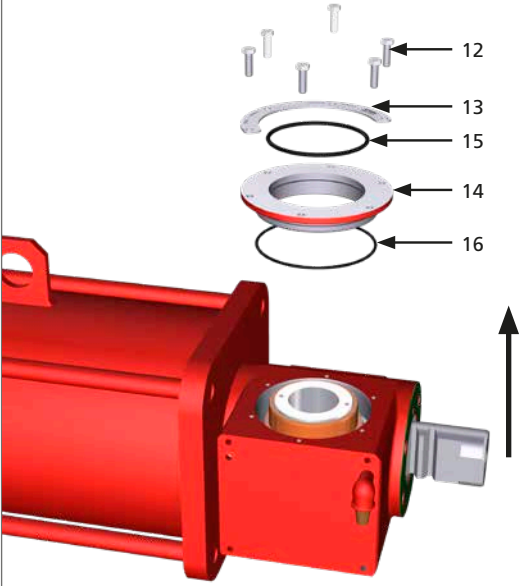
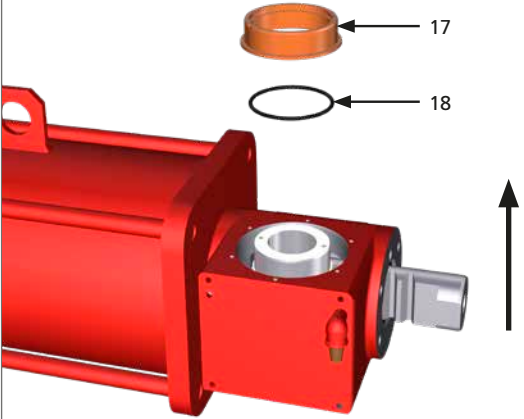
PM-RH-006		Page: 4/10
Component: Single-acting actuator RH/S and double-acting actuator RH/D2 – body sizes 015, 030, 060, 120, 240	Task: Hydraulic cylinder and centre body seal replacement	
Equipment, Tools, Materials: Spare seals Wrench Lifting tools Project documentation	Warnings: 	
Preliminary Operations: Removal from Valve		
17. Unfasten screws (12) 18. Remove plate (13) 19. Remove flange (14), O-rings (15) and (16)		
20. Remove upper brass bushing (17) and O-Ring (18)		

16. Periodic Maintenance

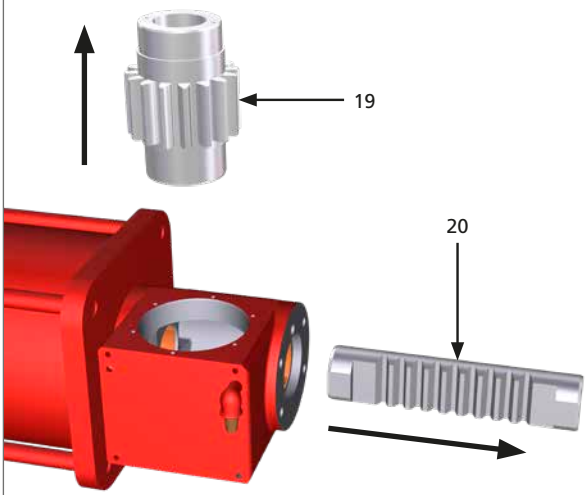
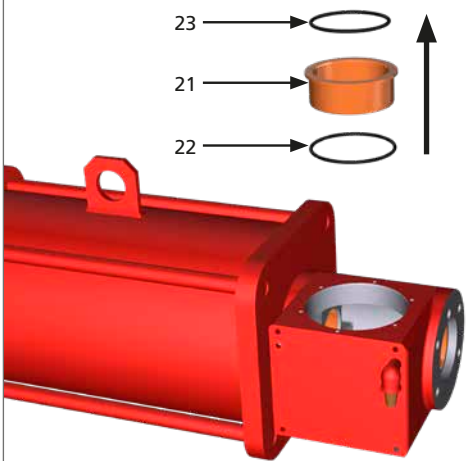
PM-RH-006		Page: 5/10
Component: Single-acting actuator RH/S and double-acting actuator RH/D2 – body sizes 015, 030, 060, 120, 240	Task: Hydraulic cylinder and centre body seal replacement	
Equipment, Tools, Materials: Spare seals Wrench Lifting tools Project documentation	Warnings: 	
Preliminary Operations: Removal from Valve		
21. Remove pinion (19) and rack (20)		
22. Remove lower brass bushing (21) and O-Rings (22, 23)		

16. Periodic Maintenance

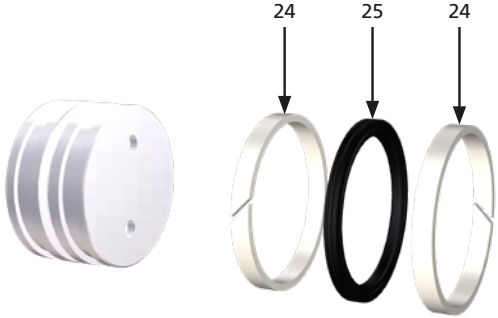
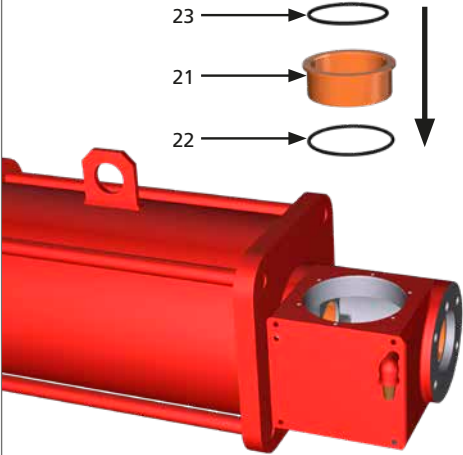
PM-RH-006		Page: 6/10
Component: Single-acting actuator RH/S and double-acting actuator RH/D2 – body sizes 015, 030, 060, 120, 240	Task: Hydraulic cylinder and centre body seal replacement	
Equipment, Tools, Materials: Spare seals Wrench Lifting tools Project documentation	Warnings: 	
Preliminary Operations: Removal from Valve		
23. Remove and replace the sliding rings (24) and seal (25) on piston		
24. Reinstall lower brass bushing (21) and replace O-Rings (22, 23)		

16. Periodic Maintenance

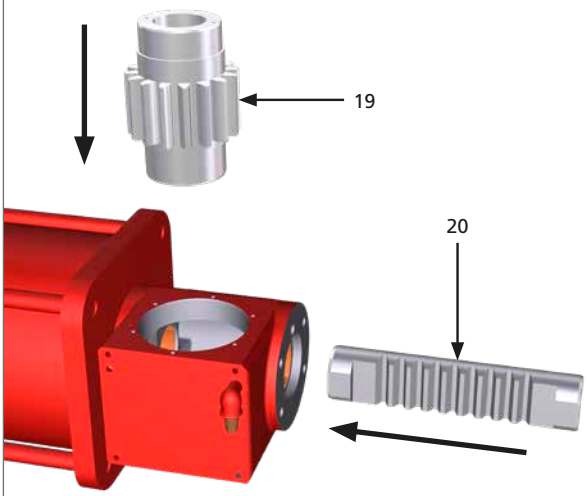
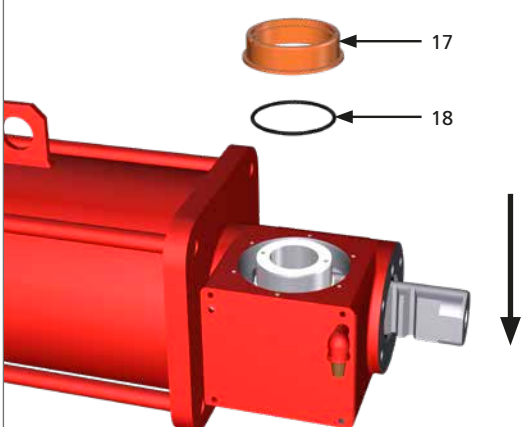
PM-RH-006		Page: 7/10
Component: Single-acting actuator RH/S and double-acting actuator RH/D2 – body sizes 015, 030, 060, 120, 240	Task: Hydraulic cylinder and centre body seal replacement	
Equipment, Tools, Materials: Spare seals Wrench Lifting tools Project documentation	Warnings: 	
Preliminary Operations: Removal from Valve		
25. Reinstall pinion (19) and rack (20). Insert the rack first to ensure pinion teeth align with the rack		
26. Reinstall upper brass bushing (17) and replace O-Ring (18)		

16. Periodic Maintenance

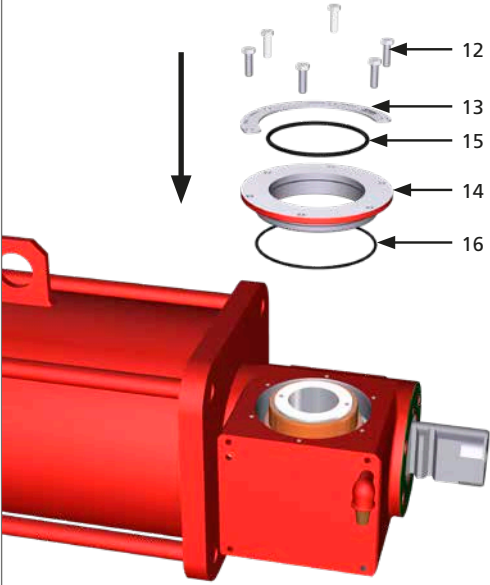
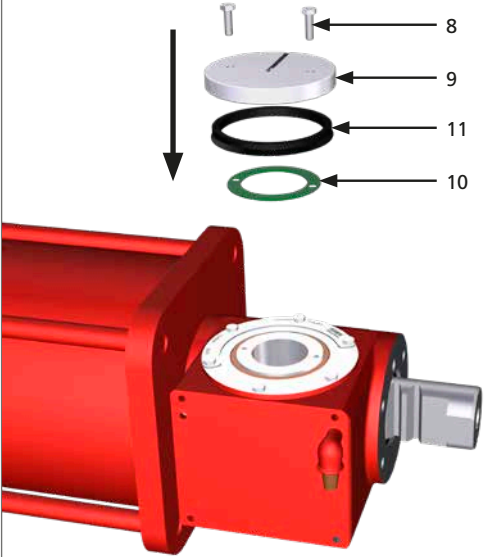
PM-RH-006		Page: 8/10
Component: Single-acting actuator RH/S and double-acting actuator RH/D2 – body sizes 015, 030, 060, 120, 240	Task: Hydraulic cylinder and centre body seal replacement	
Equipment, Tools, Materials: Spare seals Wrench Lifting tools Project documentation	Warnings: 	
Preliminary Operations: Removal from Valve		
<p>27. Reinstall flange (14) and replace O-rings (15, 16)</p> <p>28. Reinstall plate (13)</p> <p>29. Fasten screws (12)</p>		
<p>30. Reinstall top flange (9) with replacement gasket (10) and seal (11)</p> <p>31. Fasten screws (8)</p>		

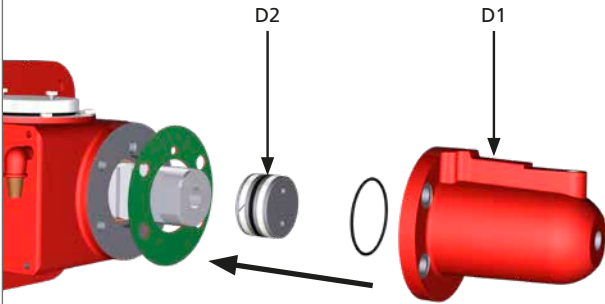
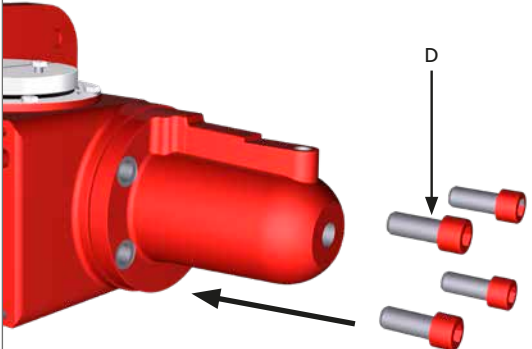
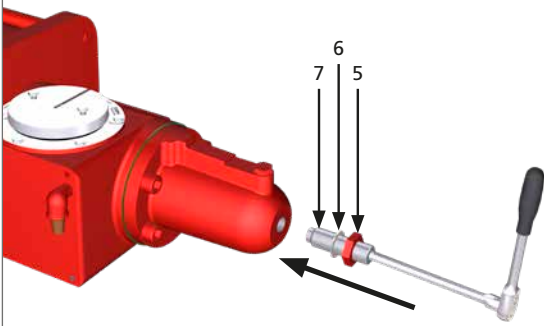

16. Periodic Maintenance

	PM-RH-006	Page: 9/10
<p>Component: Single-acting actuator RH/S and double-acting actuator RH/D2 – body sizes 015, 030, 060, 120, 240</p>	<p>Task: Hydraulic cylinder and centre body seal replacement</p>	
<p>Equipment, Tools, Materials: Spare seals Wrench Lifting tools Project documentation</p>	<p>Warnings:</p> 	
<p>Preliminary Operations: Removal from Valve</p>		
<p>32. Replace gasket and O-ring (see specific part list) between spring container and centre body 33. Reinstall piston (D2) into cylinder (D1) 34. Install cylinder (D1) to centre body</p>		
<p>35. Fasten screws (D) back into seats</p> <p>⚠ The spring cartridge module can exert a thrust against the centre body.</p>		
<p>36. Reinstall seal washer (6) and stop nut (5) 37. Screw stop bolt (7) into the cylinder</p>		

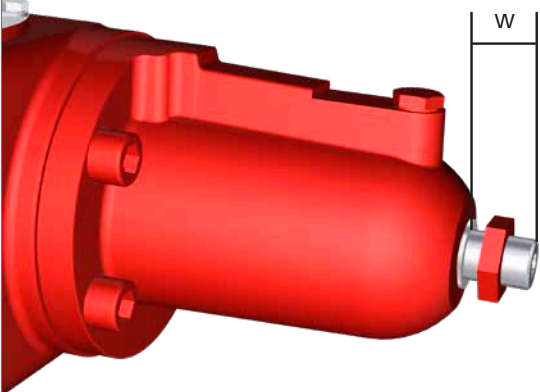
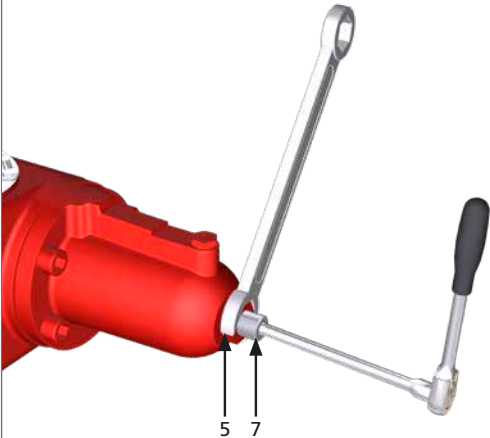
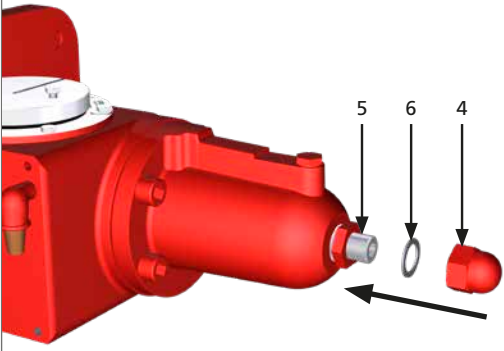
16. Periodic Maintenance

	PM-RH-006	Page: 10/10
<p>Component: Single-acting actuator RH/S and double-acting actuator RH/D2 – body sizes 015, 030, 060, 120, 240</p>	<p>Task: Hydraulic cylinder and centre body seal replacement</p>	
<p>Equipment, Tools, Materials: Spare seals Wrench Lifting tools Project documentation</p>	<p>Warnings:</p> 	
<p>Preliminary Operations: Removal from Valve</p>		
<p>38. Fasten stop bolt (7) until you measure length (W)</p>		
<p>39. Hold stop bolt (7) with an Allen (Hex.) Key and tighten the stop nut (5)</p>		
<p>40. Hold stop nut (5) with a wrench, fasten cap nut (4) with seal washer (6)</p>		
<p>41. Re-install pipes (if present)</p>		

16. Periodic Maintenance

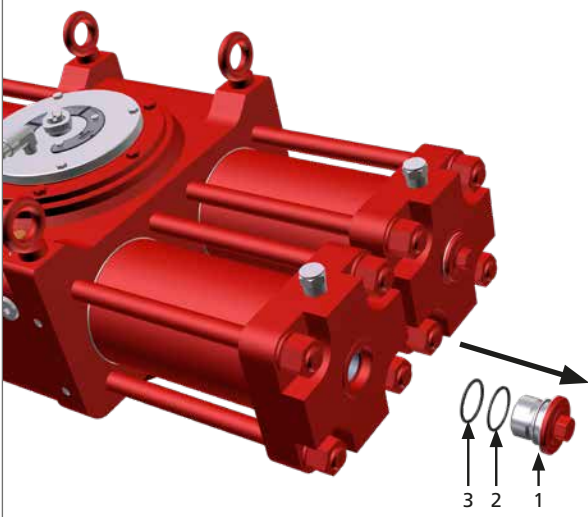
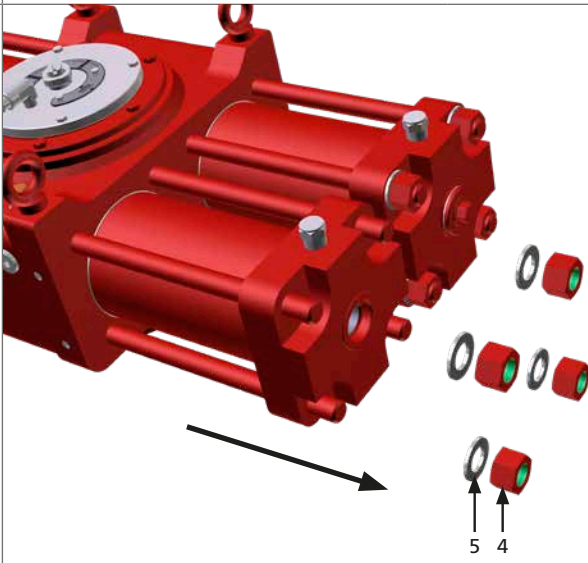
		PM-RH-007	Page: 1/12
Component: Double-acting actuator RH/D4 – body sizes 090, 105, 125, 145, 155, 185, 225, 250, 280		Task: Hydraulic cylinder and centre body seal replacement	
Equipment, Tools, Materials: Spare seals Wrench Lifting tools Project documentation		Warnings: 	
Preliminary Operations: Removal from Valve			
Description:  Isolate the hydraulic power supply and electric power supply (if present) before performing any operations. Adequate lifting devices suitable for the weight must be applied by skilled personnel.			
Preliminary actions			
<ol style="list-style-type: none"> 1. Verify actuator is in the fail position (single-acting) and not pressurised 2. Remove actuator from valve 3. Position the actuator on a workbench (if possible) or in a stable position and in a clean and closed area 4. Remove any control equipment (if present). Refer to the project specific documentation 5. Remove hydraulic pipes 			
<ol style="list-style-type: none"> 6. Remove the cap nut (1) with a wrench 7. Remove O-rings (2, 3) 			
<ol style="list-style-type: none"> 8. Unscrew nuts (4) 9. Remove washers (5) 			

16. Periodic Maintenance

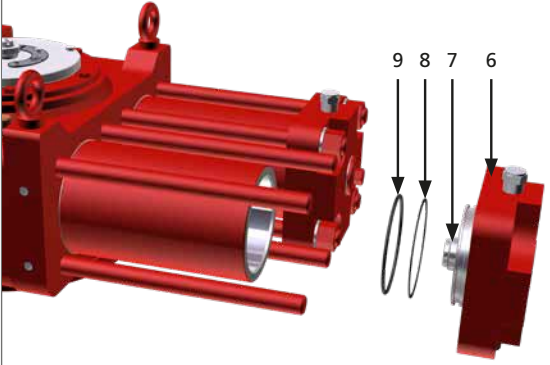
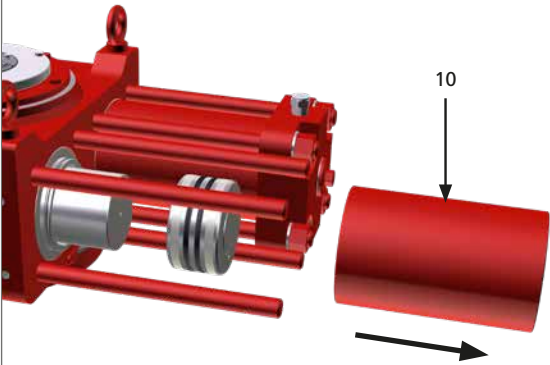
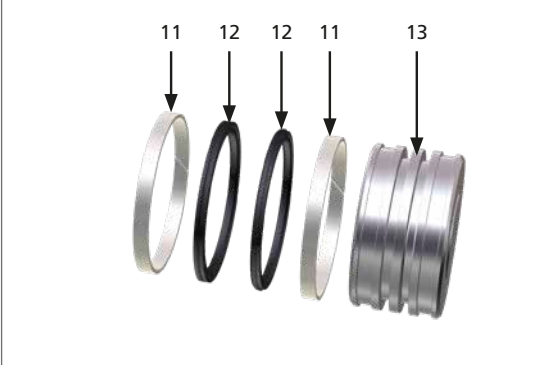
PM-RH-007		Page: 2/12
Component: Double-acting actuator RH/D4 – body sizes 090, 105, 125, 145, 155, 185, 225, 250, 280		Task: Hydraulic cylinder and centre body seal replacement
Equipment, Tools, Materials: Spare seals Wrench Lifting tools Project documentation		Warnings: 
Preliminary Operations: Removal from Valve		
10. Remove flange (6) with stop bolt (7) 11. Remove O-rings (8, 9)		
12. Remove cylinder (10) and piston (13)		
13. Remove sliding rings (11) and O-rings (12) from the piston (13)		

16. Periodic Maintenance

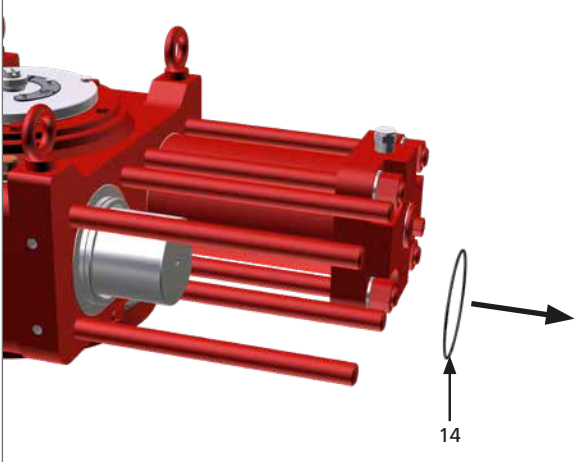
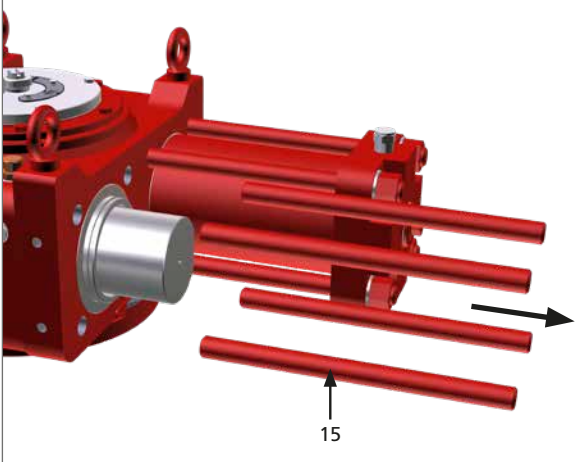
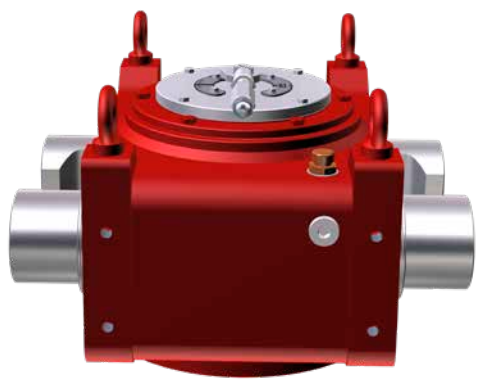
		PM-RH-007	Page: 3/12
Component: Double-acting actuator RH/D4 – body sizes 090, 105, 125, 145, 155, 185, 225, 250, 280		Task: Hydraulic cylinder and centre body seal replacement	
Equipment, Tools, Materials: Spare seals Wrench Lifting tools Project documentation		Warnings: 	
Preliminary Operations: Removal from Valve			
14. Remove O-ring (14)			
15. Remove tie rods (15)			
16. Repeat steps 6 to 15 for the other three cylinders			

16. Periodic Maintenance

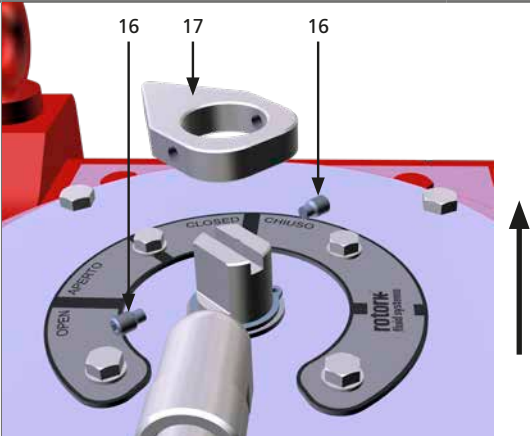
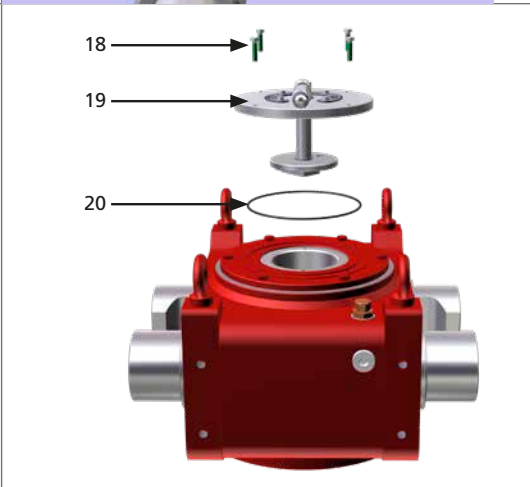
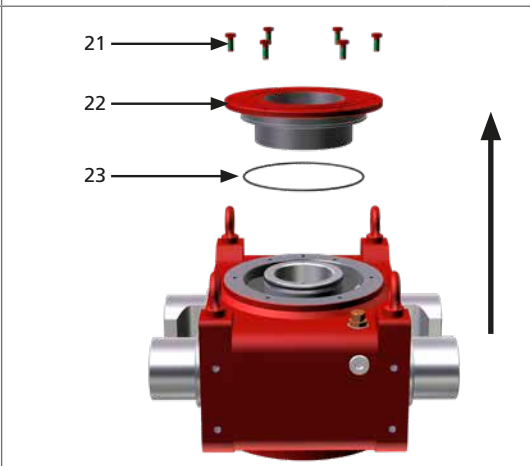
PM-RH-007		Page: 4/12
<p>Component: Double-acting actuator RH/D4 – body sizes 090, 105, 125, 145, 155, 185, 225, 250, 280</p>	<p>Task: Hydraulic cylinder and centre body seal replacement</p>	
<p>Equipment, Tools, Materials: Spare seals Wrench Lifting tools Project documentation</p>	<p>Warnings:</p> 	
<p>Preliminary Operations: Removal from Valve</p>		
<p>17. Remove grub screws (16) and position indicator (17)</p>		
<p>18. Unfasten screws (18) 19. Remove position indication subassembly (19) and O-ring (20)</p>		
<p>20. Unfasten screws (21) 21. Remove flange (22) and O-ring (23)</p>		

16. Periodic Maintenance

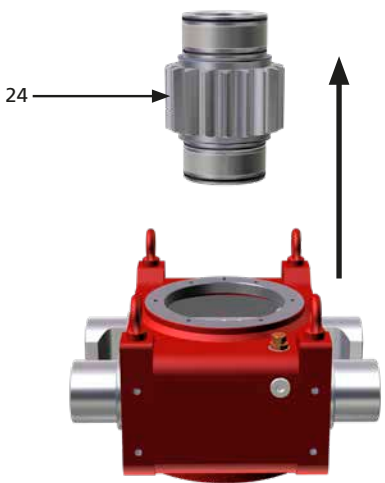
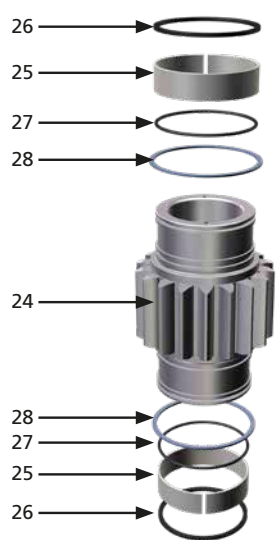
		PM-RH-007	Page: 5/12
Component: Double-acting actuator RH/D4 – body sizes 090, 105, 125, 145, 155, 185, 225, 250, 280		Task: Hydraulic cylinder and centre body seal replacement	
Equipment, Tools, Materials: Spare seals Wrench Lifting tools Project documentation		Warnings: 	
Preliminary Operations: Removal from Valve			
22. With the help of suitable lifting equipment, remove pinion (24)			
23. Remove bushings (25), O-rings (26), seals (27) and washers (28) from the pinion (24)			

16. Periodic Maintenance

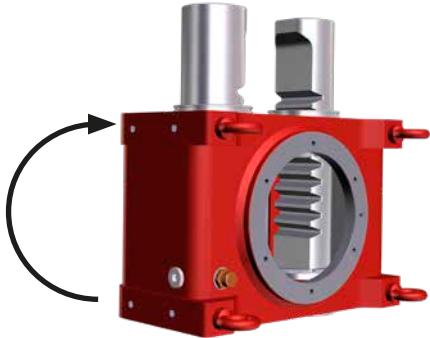
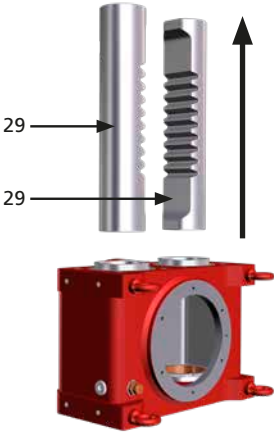
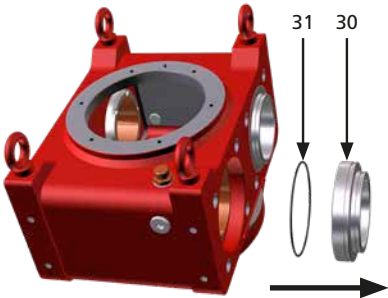
		PM-RH-007	Page: 6/12
Component: Double-acting actuator RH/D4 – body sizes 090, 105, 125, 145, 155, 185, 225, 250, 280		Task: Hydraulic cylinder and centre body seal replacement	
Equipment, Tools, Materials: Spare seals Wrench Lifting tools Project documentation		Warnings: 	
Preliminary Operations: Removal from Valve			
24. With the help of suitable lifting equipment, rotate the centre body to a vertical position			
25. Remove the racks (29)			
26. With the help of suitable lifting equipment, rotate the centre body to a horizontal position 27. Remove flange (30) and O-ring (31)			
28. Repeat step 27 for the other three rack seats			

16. Periodic Maintenance

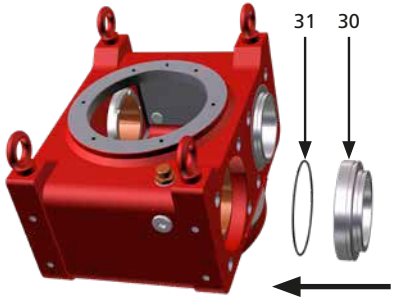
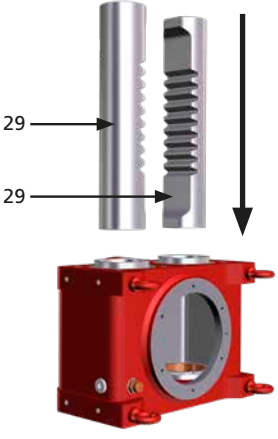
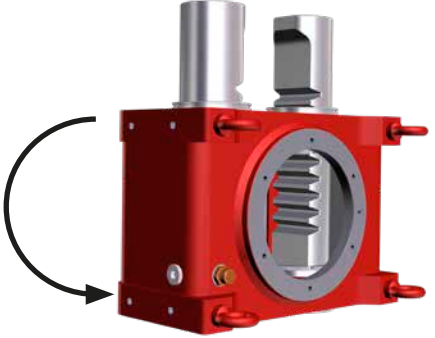
		PM-RH-007	Page: 7/12
Component: Double-acting actuator RH/D4 – body sizes 090, 105, 125, 145, 155, 185, 225, 250, 280		Task: Hydraulic cylinder and centre body seal replacement	
Equipment, Tools, Materials: Spare seals Wrench Lifting tools Project documentation		Warnings: 	
Preliminary Operations: Removal from Valve			
<p>29. Dispose of old seals and check new seals 30. Replace O-ring (31) and reinstall flange (30) 31. Repeat step 30 for the other three rack seats</p>			
32. Reinstall racks (29)			
33. With the help of suitable lifting equipment, rotate the centre body to a horizontal position			

16. Periodic Maintenance

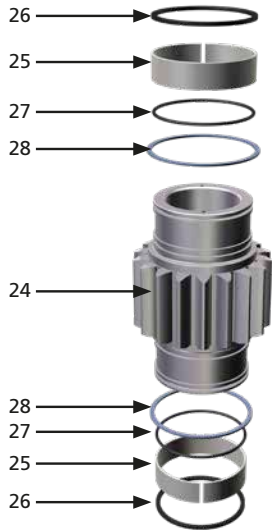
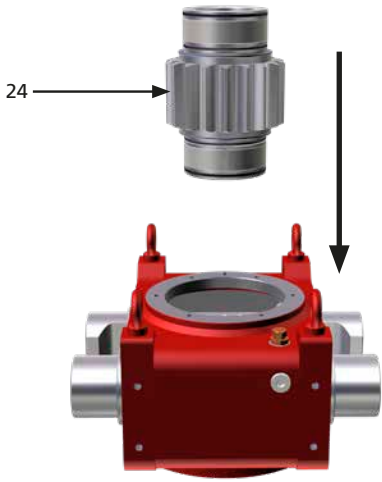
PM-RH-007		Page: 8/12
<p>Component: Double-acting actuator RH/D4 – body sizes 090, 105, 125, 145, 155, 185, 225, 250, 280</p>	<p>Task: Hydraulic cylinder and centre body seal replacement</p>	
<p>Equipment, Tools, Materials: Spare seals Wrench Lifting tools Project documentation</p>	<p>Warnings:</p> 	
Preliminary Operations: Removal from Valve		
<p>34. Replace bushings (25), O-rings (26), seals (27) and washers (28) on the pinion (24)</p>		
<p>35. With the help of suitable lifting equipment, insert the pinion (24) into the centre body</p>		

16. Periodic Maintenance

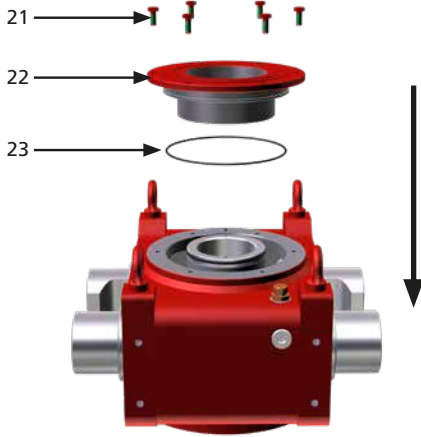
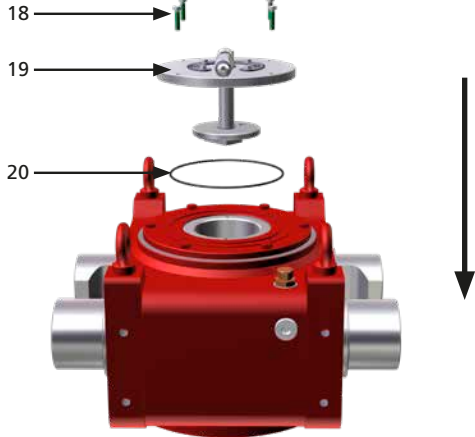
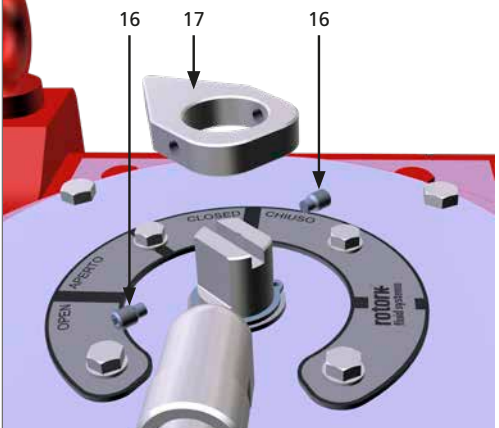
		PM-RH-007	Page: 9/12
Component: Double-acting actuator RH/D4 – body sizes 090, 105, 125, 145, 155, 185, 225, 250, 280		Task: Hydraulic cylinder and centre body seal replacement	
Equipment, Tools, Materials: Spare seals Wrench Lifting tools Project documentation		Warnings: 	
Preliminary Operations: Removal from Valve			
36. Replace O-ring (23) and reinstall flange (22) 37. Fasten screws (21)			
38. Replace O-ring (20) and reinstall the position indication subassembly (19) 39. Fasten screws (18)			
40. Reinstall position indicator (17) and grub screws (16)			

16. Periodic Maintenance

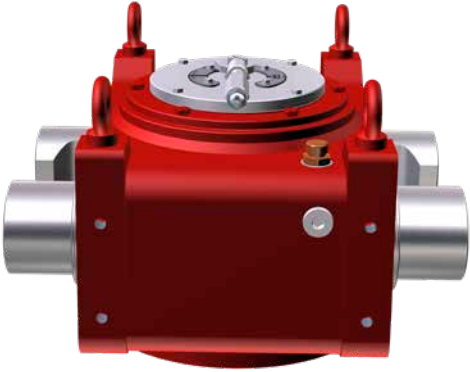
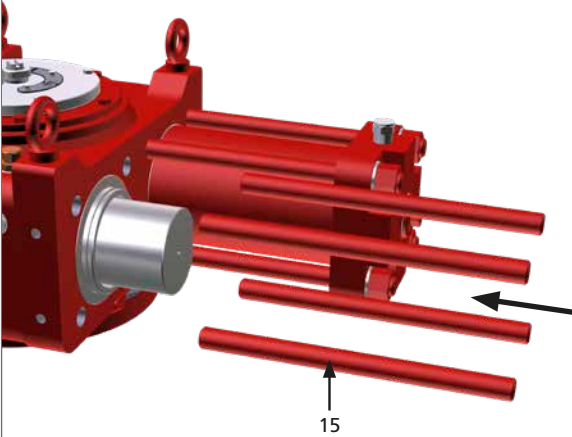
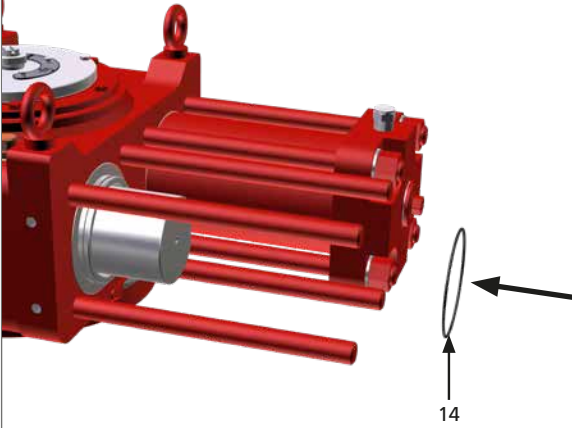
PM-RH-007		Page: 10/12
Component: Double-acting actuator RH/D4 – body sizes 090, 105, 125, 145, 155, 185, 225, 250, 280	Task: Hydraulic cylinder and centre body seal replacement	
Equipment, Tools, Materials: Spare seals Wrench Lifting tools Project documentation	Warnings: 	
Preliminary Operations: Removal from Valve		
41. Reinstall the cylinder subassemblies in the centre body as described in the following steps		
42. Reinstall tie rods (15)		
43. Replace O-ring (14)		

16. Periodic Maintenance

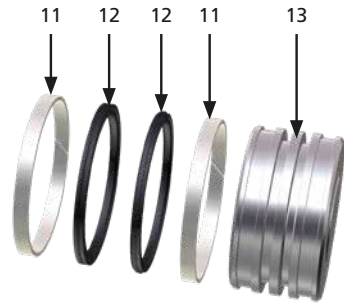
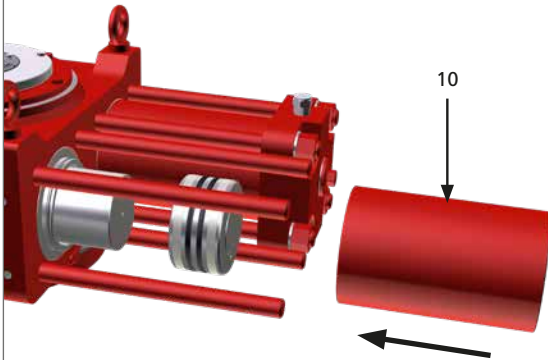
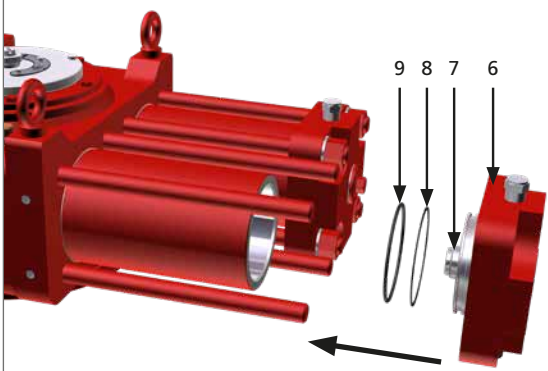
		PM-RH-007	Page: 11/12
Component: Double-acting actuator RH/D4 – body sizes 090, 105, 125, 145, 155, 185, 225, 250, 280		Task: Hydraulic cylinder and centre body seal replacement	
Equipment, Tools, Materials: Spare seals Wrench Lifting tools Project documentation		Warnings: 	
Preliminary Operations: Removal from Valve			
44. Replace sliding rings (11) and O-rings (12) on the piston (13)			
45. Reinstall piston (13) and cylinder (10)			
46. Replace O-rings (8, 9) on the flange (6) 47. Reinstall flange (6) with stop bolt (7) to the cylinder (10)			

16. Periodic Maintenance

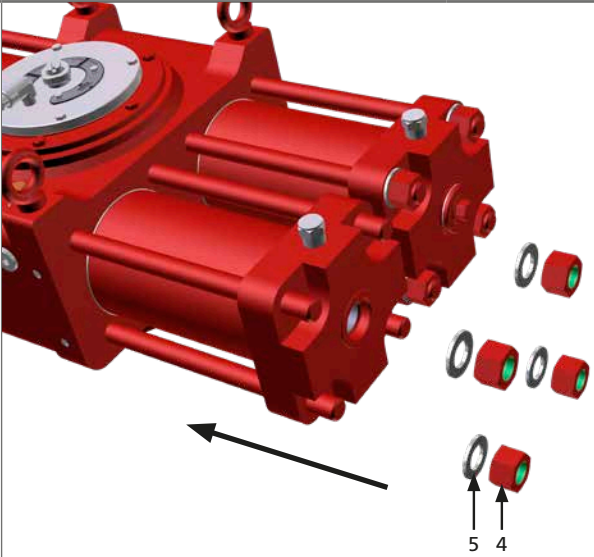
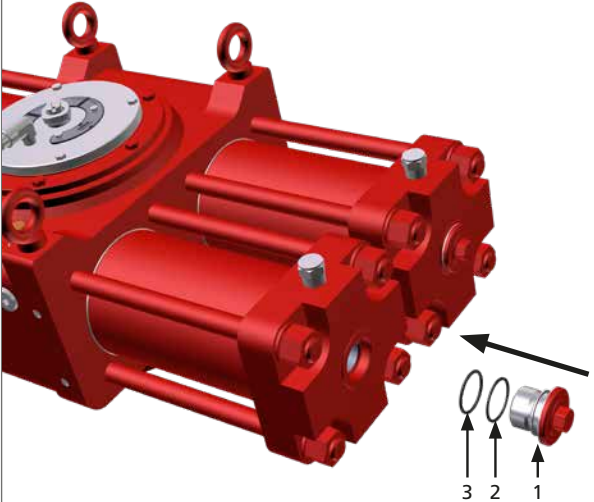
PM-RH-007		Page: 12/12
Component: Double-acting actuator RH/D4 – body sizes 090, 105, 125, 145, 155, 185, 225, 250, 280	Task: Hydraulic cylinder and centre body seal replacement	
Equipment, Tools, Materials: Spare seals Wrench Lifting tools Project documentation	Warnings: 	
Preliminary Operations: Removal from Valve		
<p>48. Reinstall washers (5) 49. Fasten nuts (4)</p>		
<p>50. Replace O-rings (2, 3) on the cap nut (1) 51. Reinstall the cap nut (1) with a wrench</p>		
<p>52. Repeat steps 42 to 51 for the other three cylinders</p>		

17. Part List

RH/S ACTUATOR– center body sizes 015, 030, 060, 120, 240

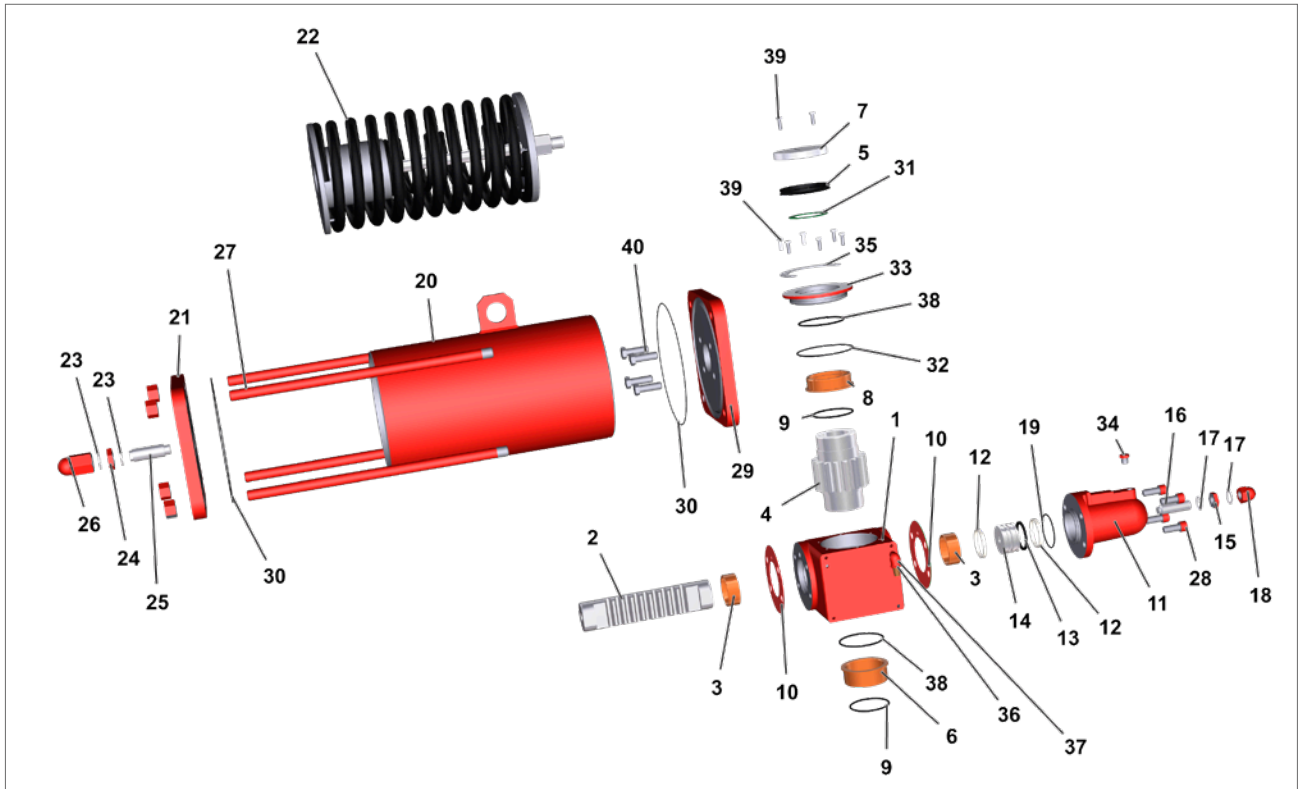

Fig 17.1 RH Single-acting actuator

ITEM	DESCRIPTION		QTY
1	Centre body	●	1
2	Rack		2
3	Rack bushing		2
4	Pinion		1
5	Position indicator seal	●	1
6	Lower bushing		1
7	Position indicator		2
8	Upper bushing		1
9	O-ring	●	2
10	Cylinder gasket	●	2
11	Cylinder		1
12	Sliding ring		2
13	O-Ring	●	1
14	Piston		1
15	Stop nut		1
16	Stop bolt	●	1
17	Seal washer		2
18	Blind nut		1
19	O-Ring	●	1
20	Spring container		1

ITEM	DESCRIPTION		QTY
21	Spring container end flange		1
22	Spring cartridge		1
23	Seal washer		4
24	Stop nut		2
25	Stop bolt		1
26	Blind nut		1
27	Tie rod		4
28	Screw		4
29	Spring container tail flange		1
30	O-Ring	●	2
31	Position indicator gasket	●	1
32	Position indicator O-ring	●	1
33	Pinion retaining flange		1
34	Plug		1
35	Position indication plate		1
36	Silencer		1
37	Elbow		1
38	O-Ring	●	1
39	Screw		8
40	Spring container screws		4

● Recommended spare part

17. Part List

RH/D2 ACTUATOR – Center body sizes 015, 030, 060, 120, 240

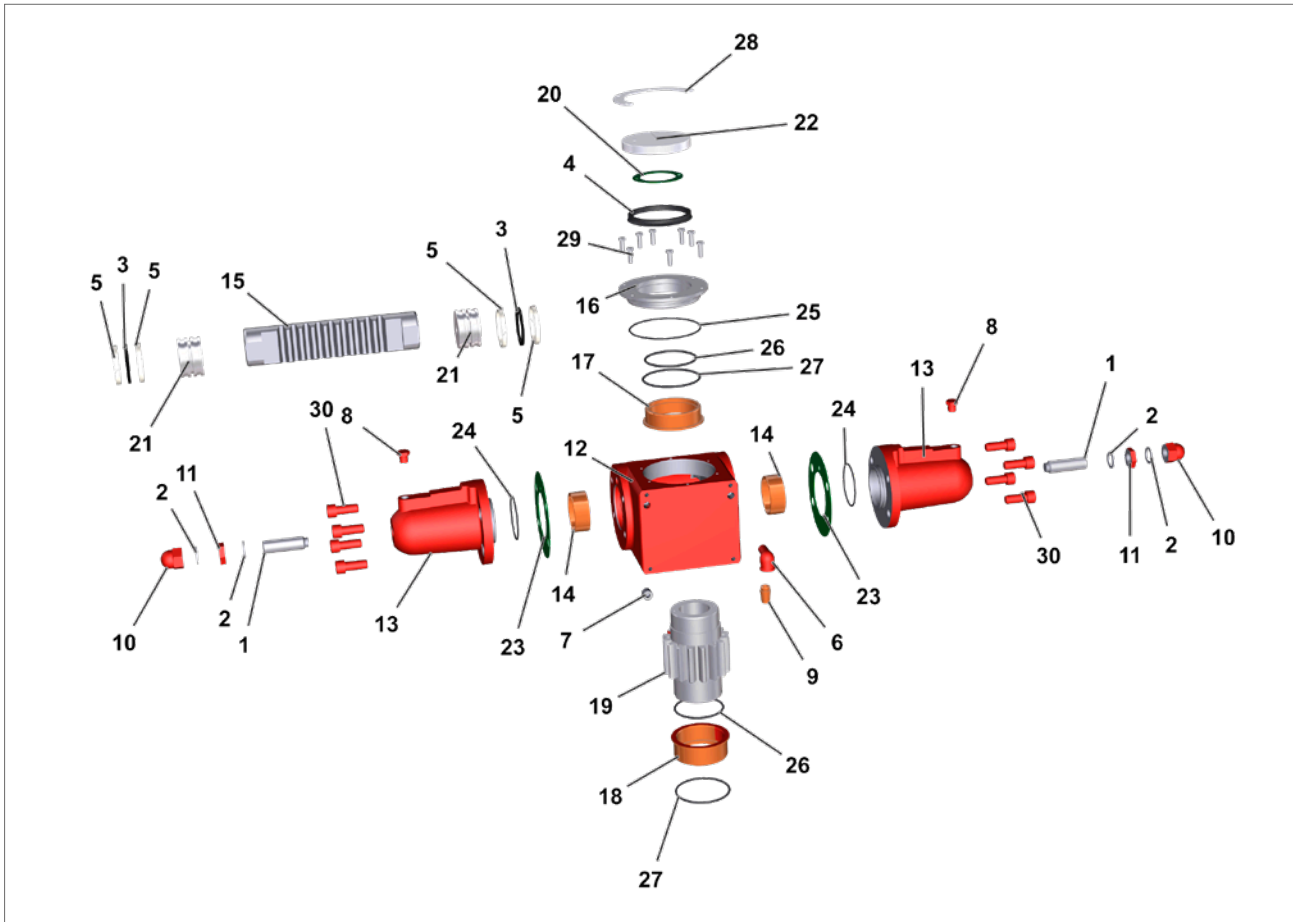

Fig 17.2 RH/D2 double-acting (2 cylinders) actuator

ITEM	DESCRIPTION	QTY
1	Stop bolt	2
2	Seal washer	2
3	O-ring	● 2
4	Position indicator seal	● 1
5	Sliding ring	4
6	Elbow	1
7	Plug	1
8	Cylinder plug	2
9	Silencer	1
10	Blind nut	2
11	Nut	2
12	Centre body	1
13	Cylinder	2
14	Rack bushing	2
15	Rack	1

ITEM	DESCRIPTION	QTY
16	Pinion retaining flange	1
17	Upper bushing	1
18	Lower bushing	1
19	Pinion	1
20	Position indicator gasket	● 1
21	Piston	2
22	Position indicator	1
23	Cylinder gasket	2
24	O-Ring	● 2
25	O-Ring	● 4
26	O-Ring	● 1
27	Position indicator O-ring	● 1
28	Position indication plate	1
29	Screws	8
30	Cylinder screw	8

● Recommended spare part

17. Part List

RH/D4 ACTUATOR – Center body sizes 090, 105, 125, 145, 155, 185, 225, 250, 280

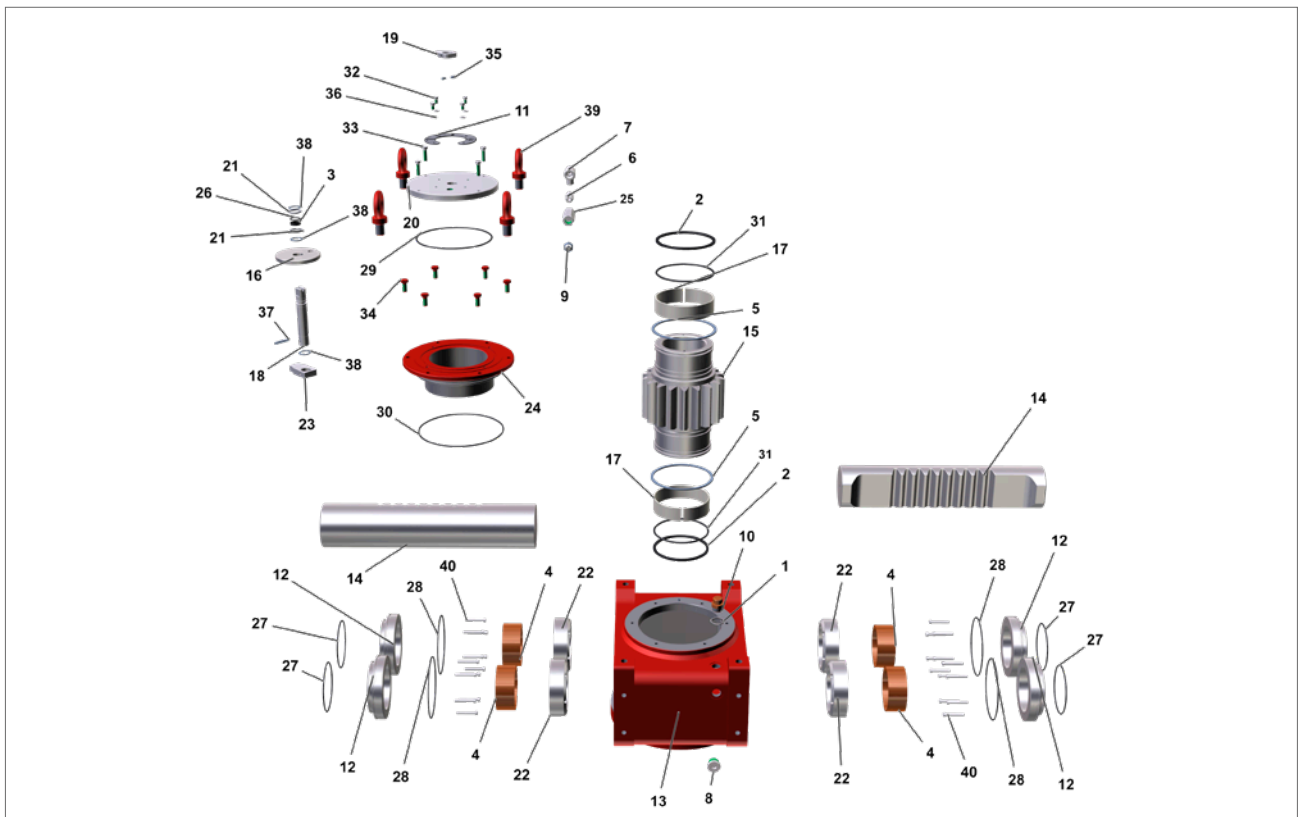

Fig 17.3 Centre body RH/D4 double-acting (4 cylinders actuator)

ITEM	DESCRIPTION	QTY
1	Washer	1
2	Seal	2
3	Sliding ring	1
4	Bushing	4
5	Washer	2
6	Spacer	1
7	Elbow	1
8	Plug	1
9	Silencer	1
10	Breather	1
11	Position indicator plate	1
12	Bushing retaining flange (front)	4
13	Centre body	1
14	Rack	2
15	Pinion	1
16	Flange	1
17	Pinion bushing	2
18	Position indicator stem	1
19	Position indicator	1
20	Top flange	1

ITEM	DESCRIPTION	QTY
21	Washer	2
22	Bushing retaining flange (back)	4
23	Position indicator	4
24	Pinion retaining flange	1
25	Spacer	1
26	O-ring	1
27	O-ring	4
28	O-ring	4
29	O-ring	1
30	O-ring	1
31	O-ring	2
32	Screws	4
33	Screws	4
34	Screws	6
35	Grub screw	2
36	Washer	4
37	Pin	1
38	Circlip	3
39	Eyebolt	4
40	Screw	24

● Recommended spare part

17. Part List

RH/D4 ACTUATOR – Center body sizes 090, 105, 125, 145, 155, 185, 225, 250, 280 – Hydraulic cylinder

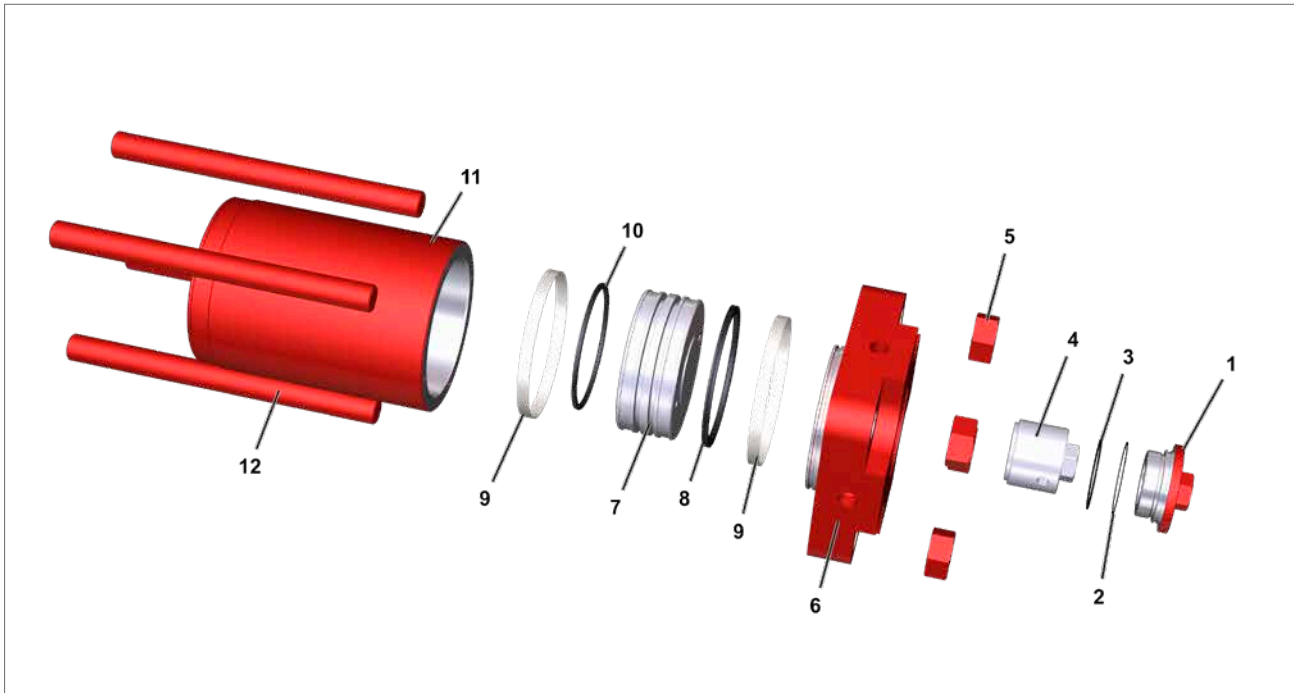

Fig 17.4 Hydraulic cylinder RH/D4 double-acting (4 cylinders) actuator

ITEM	DESCRIPTION	QTY
1	Plug	1
2	O-Ring	● 1
3	O-Ring	● 1
4	Stop bolt	1
5	Nut	4
6	Cylinder flange	1

ITEM	DESCRIPTION	QTY
7	Piston	1
8	Piston Seal	● 1
9	Sliding ring	● 2
10	O-Ring	● 1
11	Cylinder	1
12	Tie rod	4

● Recommended spare part

18. Grease and Hydraulic Oil Specification

In general, there is no need to lubricate the actuator because its mechanism is lubricated for life. The standard grease for Rotork rack and pinion actuators are shown below. If an alternative was specified and/or supplied, please refer to the job specific documentation.

18.1 Grease

Lubricate components of the rack and pinion mechanism using the following grease or equivalent for temperature range -30 to +100 °C (-22 to +212 °F).

Manufacturer:	Dow Corning Corporation
Trade name: Colour:	MOLIKOTE® P40 Clear Brown
Unworked penetration (ISO 2137): Viscosity of oil at 40 °C (104 °F) (DIN 51 562):	310-350 mm/10 360 mm ² /s
Service temperature: Drop point (ISO 2176):	-40 to 230 °C (-40 to 446 °F) None
Four ball tester Weld load (Din 51 350 pt.4) Wear scar under 800N load (Din 51 350 pt.5)	3000 N 0.94 mm
Coefficient of friction ^[1] Screw test - μ thread Screw test - μ head	0.16 0.08

1. Coefficient of friction in bolted connection, M12x1.75, 8.8, on blackened surface.

Lubricate components of the rack and pinion mechanism using the following grease or equivalent for temperature range -60 to +100 °C (-76 to +212 °F).

Manufacturer:	Mobil
Trade name:	MOBILTHEMP® SHC100™
NLGI grade:	2
Colour:	Clear brown
Penetration, density, viscosity Worked penetration at 25 °C (77 °F) (ASTM D 217): Viscosity of oil at 40 °C (104 °F) (ASTM D445):	280 100 CSt
Temperature Drop point (ASTM D 2265):	>260 °C (>500 °F)
Load-carrying capacity, wear protection, service life Four ball tester (ASTM D 2266) Weld load (ASTM D 2596) Corrosion protection (ASTM D6138)	0.4 mm >200 0

Centre body must be filled with grease, until all the pinion teeth are covered.

18. Grease and Hydraulic Oil Specification

18.2 Hydraulic Oil

This is the standard oil specification for hydraulic cylinders working at temperature range -20 to +100 °C (-4 to +212 °F) for ATEX and non-ATEX application.

Manufacturer:	MOBIL
Trade Name:	DTE 10 EXCEL 32
ISO Viscosity Grade:	32
Viscosity, ASTM D 445 cSt @ 40 °C (104 °F) cSt @ 100 °C (212 °F)	32.7 6.63
Viscosity Index, ASTM D 2270	164
Brookfield Viscosity ASTM D 2983, cP @ -20 °C (-4 °F)	1090
Brookfield Viscosity ASTM D 2983 cP @ -30 °C (-22 °F)	3360
Brookfield Viscosity ASTM D 2983 cP @ -40 °C (-40 °F)	14240
Tapered Roller Bearing (CEC L-45-A-99), %Viscosity Loss	5
Density 15 °C (59 °F), ASTM D 4052, kg/L	0.8468
Copper Strip Corrosion, ASTM D 130, 3 hrs @ 100 °C (212 °F)	1B
Rust Characteristics, ASTM D 665B	Pass
FZG Gear Test, DIN 51534, Fail Stage	12
Pour Point, ASTM D 97	-54 °C (-65 °F)
Flash Point, ASTM D 92	250 °C (482 °F)
Foam Sequence I, II, III, ASTM D 892, ml	20/0
Dielectric Strength, ASTM D877, kV	49
Acute Aquatic Toxicity (LC-50, OECD 203)	Pass

This is the standard oil specification for hydraulic cylinders working at temperature range -40 to +100 °C (-40 to +212 °F) for ATEX and non-ATEX application.

Manufacturer:	MOBIL
Trade Name:	DTE 10 EXCEL 15
ISO Viscosity Grade:	15
Viscosity, ASTM D 445 cSt @ 40 °C (104 °F) cSt @ 100 °C (212 °F)	15.8 4.07
Viscosity Index, ASTM D 2270	158
Brookfield Viscosity ASTM D 2983 cP @ -40 °C (-40 °F)	2620
Tapered Roller Bearing (CEC L-45-A-99), %Viscosity Loss	5
Density 15 °C (59 °F), ASTM D 4052, kg/L	0.8375
Copper Strip Corrosion, ASTM D 130, 3 hrs @ 100 °C (212 °F)	1B
Pour Point, ASTM D 97	-54 °C (-65 °F)
Flash Point, ASTM D 92	182 °C (360 °F)
Foam Sequence I, II, III, ASTM D 892, ml	20/0
Dielectric Strength, ASTM D877, kV	45
Acute Aquatic Toxicity (LC-50, OECD 203)	Pass

18. Grease and Hydraulic Oil Specification

This is the standard oil specification for hydraulic cylinders working at temperature down to -60 °C (-76 °F) for non-ATEX applications.

Manufacturer:	MOBIL
Trade Name:	UNIVIS HVI
ISO Viscosity Grade:	32
Viscosity, ASTM D 445 cSt @ 40 °C (104 °F) cSt @ 100 °C (212 °F)	13.5 5.3
Viscosity Index, ASTM D 2270	404
Kinematic Viscosity @ -40 °C (-40 °F), ASTM D 445	371 cSt
Copper Strip Corrosion, ASTM D 130	1A
Pour Point, ASTM D 97	-60 °C (-76 °F)
Flash Point, ASTM D 92	101 °C (214 °F)

This is the standard oil specification for hydraulic cylinders working at temperature range -60 to +90 °C (-76 to +194 °F) for ATEX application.

Manufacturer:	TECCEM
Trade Name:	SynTop 1003 FG
ISO Viscosity Grade:	3
Viscosity, ASTM D 445 cSt @ -40 °C (-40 °F) cSt @ -55 °C (-67 °F) cSt @ 40 °C (104 °F)	73 2.6 3.2
Pour Point, ASTM D 97	-88 °C (-126 °F)
Flash Point, ASTM D 92	140 °C (284 °F)
Density 20 °C (68 °F), kg/L	0.86

An alternative oil may have been specified for your application. Please refer to the job specific documentation.

Please note that the above specifications for Grease and Hydraulic oil apply to RH/S and RH/D2 actuators (body sizes 015, 030, 060, 120, 240)

For RH/D4 actuator (body sizes 090, 105, 125, 145, 155, 185, 225, 250, 280) please refer to the relevant job documentation.

rotork®



www.rotork.com

A full listing of our worldwide sales and service network is available on our website.

Rotork plc
Brassmill Lane, Bath, UK
tel +44 (0)1225 733200
email mail@rotork.com

PUB019-018-00
Issue 08/21

All Rotork actuators are manufactured under a third party accredited ISO9001 quality assurance programme. As we are continually developing our products, their design is subject to change without notice.
The name Rotork is a registered trademark. Rotork recognises all registered trademarks. Published and produced in the UK by Rotork. POWB0821