

# rotork®

Keeping the World Flowing  
for Future Generations

## GO/2 Range ATEX/IEC Ex Application

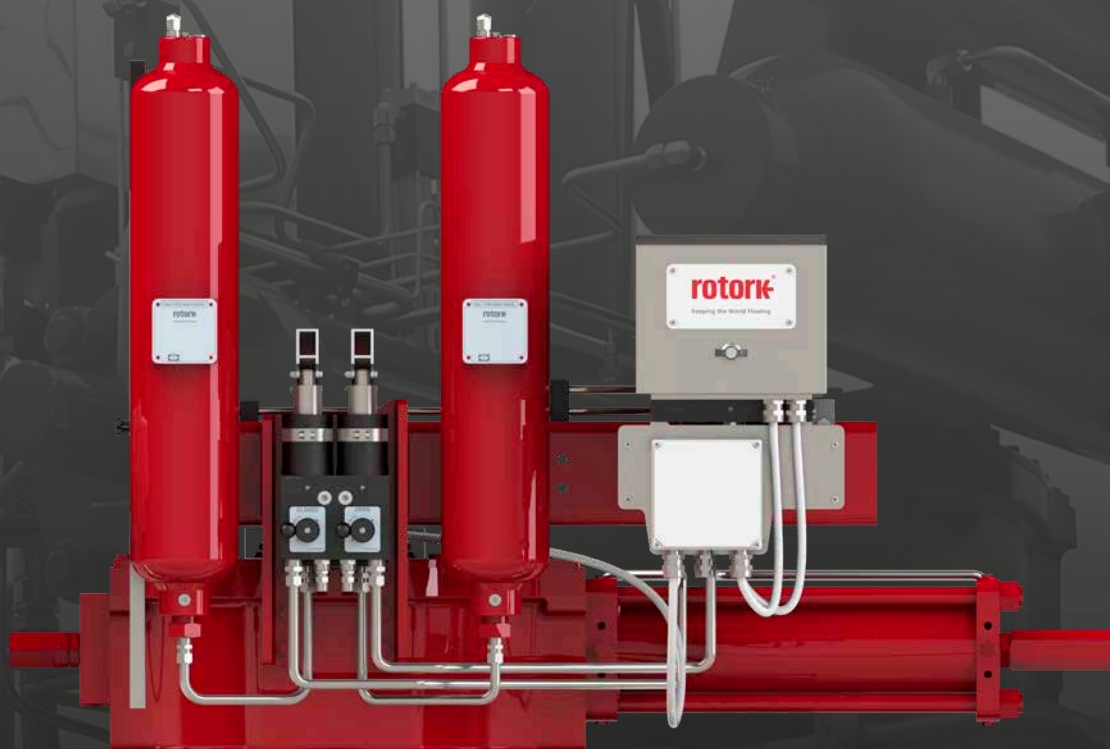

Installation, Commissioning and Maintenance Manual

## Contents

---

Section	Page	Section	Page
1. Introduction	3	11. Removal from Valve	11
2. Standards and Regulations	3	12. Operation	12
3. General Information	4	12.1 Description	12
4. Health and Safety	4	12.2 Operating Description	13
4.1 Residual Risks	4	12.3 Angular Stroke Setting	13
4.2 Thermal Risks	4	12.4 Limit Switch Setting	15
4.3 Health Risks	4	12.5 Flow Regulator Setting	16
4.4 Mechanical Risks	4	12.6 Pipeline Gas Power Supply	17
4.5 Noise	5	12.7 Connection To Pipeline	17
4.6 Electrostatic Risks	5	12.8 Electrical Connections	18
5. Labels and Nameplates	5	12.9 Start Up	19
5.1 Labels	5	12.10 Gas-Oil Tank Connections Restoration	19
5.2 Nameplates	7	12.11 Circuit Gas Venting	20
6. Operating Limits	7	13. Dismantling and Disposal	21
6.1 Temperature	7	14. Rotork Sales and Service	21
6.2 Allowed Fluid Types	7	15. Troubleshooting	22
6.3 Expected Lifetime	7	16. Periodic Maintenance	24
7. Handling and Lifting	8	17. Part List	48
7.1 Lifting Recommendations	8	18. Grease and Hydraulic Oil Specification	48
7.2 Lifting Instructions	8	18.1 Grease	48
8. Storage	9	18.2 Hydraulic Oil	49
9. Long Term Storage	9		
10. Installation on Valve	10		
10.1 Preliminary Actions	10		
10.2 Instructions	10		

**THIS MANUAL CONTAINS IMPORTANT SAFETY INFORMATION. PLEASE ENSURE IT IS THOROUGHLY READ AND UNDERSTOOD BEFORE INSTALLING, OPERATING OR MAINTAINING THE EQUIPMENT.**

**ROTORK RESERVES THE RIGHT TO MODIFY, AMEND AND IMPROVE THIS MANUAL WITHOUT NOTICE.**

**ROTORK IS NOT RESPONSIBLE FOR DAMAGE OR INJURY CAUSED BY THE FAILURE TO OBSERVE THE INSTRUCTIONS CONTAINED HEREIN.**

## 1. Introduction

This manual covers the Gas-Over Oil (GO) (type 2) actuator range.

In this manual, warning indications are represented by icons, according to ISO 7010 Safety Signs:



Generic danger



Hand crush/pinch point



Electrocution



Explosive material



Substances toxic for the environment (terrestrial or aquatic) or which could have harmful, long-term effects

### Customer Service

For technical assistance, please contact the Rotork customer service:

E-mail: [rfs.international@rotork.com](mailto:rfs.international@rotork.com)

Rotork, Via Padre Jacques Hamel, 138B, Porcari, Lucca, 55016, IT. Tel: +39 0583-222-1

Rotork plc, Brassmill Lane, Bath, UK. Tel +44 (0)1225 733200

## 2. Standards and Regulations

Actuators destined for European member states have been designed, built and tested according to the Quality Control System, in compliance with the EN ISO 9001:2015 standard and with the following regulations/directive.

- 2006/42/EC: Machinery Directive.
- 2014/68/EU: Pressure Equipment Directive (PED).
- 2014/34/EU: Directive for safety equipment and systems to be used in potentially explosive atmospheres (ATEX).
- 2014/30/EU: Electromagnetic Compatibility Directive.
- EN ISO 12100: Machinery Safety Directive.
- EN 60079-14: Explosive atmospheres - Part 14: Electrical installations design, selection and erection.
- ISO 80079-36: Non-electrical equipment for explosive atmospheres - Basic method and requirements.
- EN 1127-1: Explosive atmospheres – Explosion prevention and protection.
- ISO 80079-37: Non-electrical equipment for explosive atmospheres - Non-electrical type of protection construction safety "c", control of ignition sources "b", liquid immersion "k".
- EN ISO 7010: Safety Signals.
- EN13445: Unfired Pressure Vessels.

### 3. General Information

This manual is produced to enable a competent user to install, operate, adjust, inspect, maintain, dismantle and dispose Rotork GO/2 Range actuators.

The mechanical installation should be carried out as outlined in this manual and also in accordance with any relevant national standard codes of practice.

Maintenance and operation should be carried out in accordance with the National Legislation and Statutory Provisions relating to the safe use of this equipment, applicable to the site of installation.

Any inspection or repair in a Hazardous Area should not be undertaken unless it conforms to National Legislation and Statutory Provisions relating to the specific Hazardous Area.

Only Rotork approved replacement parts should be used. Under no circumstances should any modification or alteration be carried out on the equipment, as this could invalidate the conditions under which its certification was granted.

Only trained and experienced operators should be allowed to install, maintain and repair Rotork actuators. Work undertaken must be carried out in accordance with instructions in this manual. The user and those persons working on this equipment should be familiar with their responsibilities under any statutory provisions relating to the Health and Safety of their workplace.

Operators should always wear appropriate personal protection devices (PPDs) in line with the existing plant regulations.

#### Appropriate Usage

Rotork Gas over Oil actuators (GO/2) series have been specifically developed to motorize ¼" turn valves such as ball valves, butterfly valves or plug valves, installed on pipelines for gas transport and distribution.

**⚠ Improper use can damage the equipment or cause dangerous situations for health and safety. Rotork declines any responsibility for damage to people and /or objects resulting from the use of the equipment for applications different from those described in the present manual.**

### 4. Health and Safety

GO actuators are filled with hydraulic oil (section 18.2).

**⚠ Hydraulic oil is hazardous material. Consult the Material Safety Data Sheet (MSDS), available upon request, for detailed health and safety information.**

**⚠ Hydraulic fluid is a hazardous substance. Always wear appropriate protective devices during maintenance activities.**

**⚠ Do not use the actuator in presence of naked flames.**

#### 4.1 Residual Risks

Residual risks resulting from equipment risk evaluation performed by Rotork.

#### 4.2 Thermal Risks

Risk	Hot/cold surfaces during normal operation (RES_01).
Preventive measures	Operators should wear protective gloves.
Risk	In the presence of dust, equipment surface temperature must not exceed 2/3 of the ignition temperature of the dust. Dust ignition temperature is reduced by 75 °C if a 5 mm thick coating builds up.
Preventive measures	Keep equipment surfaces clean by planning regular cleaning maintenance using a suitable wet anti-static cloth.

#### 4.3 Health Risks

Risk	Pressurized fluid ejection during normal operation (RES_02).
Preventive measures	All fittings must be properly sealed. All fixing clamps must be correctly tightened and sealed.
Risk	Risk of intoxication (according to the type of medium utilized) (RES_06).
Preventive measures	Operators must use P.P.Ds and any other equipment (breathing apparatus) based on the type of supply medium.

#### 4.4 Mechanical Risks

Risk	Uncontrolled movement (remote operation) (RES_03).
Preventive measures	Assure that the actuator can not be operated remotely. Prior to starting, remove pneumatic supply, vent all pressure vessels, and remove electrical power.
Risk	Presence of moving parts (center body, in the valve adapter) (RES_04).
Preventive measures	Check center body cover is installed and hex bolts tightened before start-up.

## 4. Health and Safety

### 4.5 Noise

Risk	Noise >85 dB during operation (RES_05).
Preventive measures	Operators should wear ear protections. Operators should not stand near the equipment during operation.

### 4.6 Electrostatic Risks

Risk	Non-conductive parts of the equipment can build an electrostatic charge which is dangerous in hazardous areas.
Preventive measures	Do not polish/rub surfaces with a dry cloth. Only clean equipment surfaces with a suitable wet anti-static cloth. Operators must wear suitable anti-static clothing and use tools that will not generate a static charge. The user must ensure the operating environment and any materials surrounding the actuator cannot lead to a reduction in the safe use of, or the protection afforded by, the actuator.

## 5. Labels and Nameplates

### 5.1 Labels

GO2 Actuators manufactured after November 2015, are provided with the following labels:

- Oil refill/dipstick: to indicate the presence of the dipstick for oil level control and refill (see Fig 5.1, Fig 5.2)
- Oil type: to indicate the type of oil to be used in the gas-oil tank (see Fig 5.3 and Fig 5.4)
- Oil level: to indicate the oil level in the gas-oil tank in the Open and Close position (see Fig 5.5, Fig 5.6 for reference only).
- Lifting: to indicate lifting point and recommendations for correct lifting (see Fig 5.7, Fig 5.8 for reference only)



Fig 5.1 Oil Refill Label



Fig 5.2 Example of Oil Refill Label



Fig 5.3 Oil Type Label



Fig 5.4 Example of Oil Type Label

## 5. Labels and Nameplates

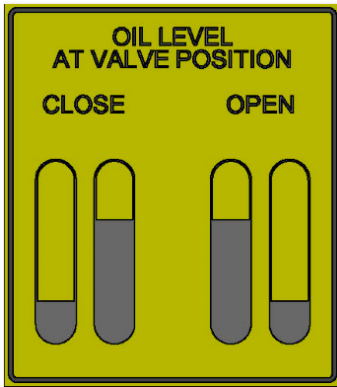

Fig 5.5 Oil Level Label

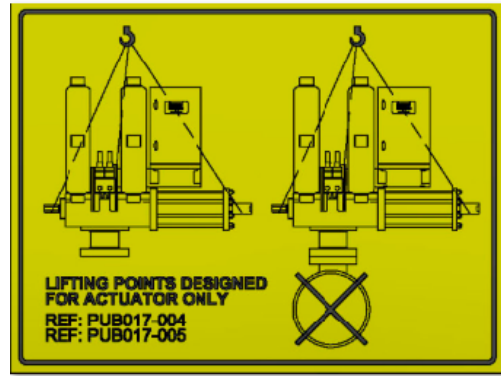

Fig 5.7 Lifting Label



Fig 5.6 Example of Oil Level Label

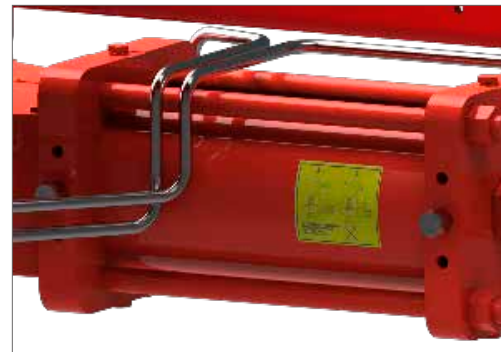

Fig 5.8 Example of Lifting Label

## 5. Labels and Nameplates

### 5.2 Nameplates

For actuators destined for site within the European Union, the CE mark certifies the conformity of the machine with the essential health and safety requirements of the European Directives for the product. The plate is applied externally on the center body cover and displays, the following data:

- Serial number
- Tag number
- Model
- Min/max operating pressure
- Order number
- Month/year of manufacture
- ATEX protection
- CE conformity marking
- Name of technical file deposited with a notified body

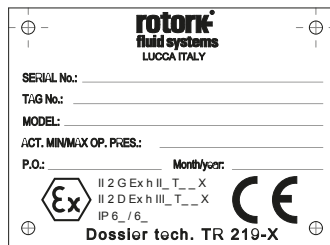

Fig 5.9 Actuator label

ATEX Type of Protection: constructional safety "c".

If CE (PED) marking is required, the following plate applies:

- Serial number
- Cylinder code
- 2014/68/EU category
- Fluid
- Volume (lt.)
- Production month and year
- Maximum working pressure
- Design pressure
- Testing pressure
- Minimum/Maximum design temperature
- CE conformity marking
- Notified body number 1370

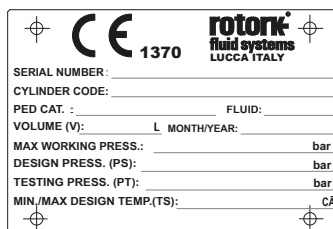

Fig 5.10 Actuator PED nameplate

Do not remove or modify the nameplate/s. Nameplate must be kept legible at all times. In case the plate is damaged or illegible, a duplicate must be requested.

## 6. Operating Limits

**Do not use the actuator for applications outside its operating limits.**

Verify operating limits on the nameplate.

Between two consecutive operations (Open/Close), a dwell time of 1 Minute (minimum) must be observed to avoid oil foaming.

### 6.1 Temperature

- Standard: -29 to +60 °C (-20 to +140 °F)
- Low: -46 to +40 °C (-51 to +104 °F)

Prevent external surface temperature to reach the ignition point in potentially explosive environments.

The actuator surface temperature is strictly dependent on the temperature of the process fluid used and by the irradiation's conditions. The end user has to check the surface temperature of the assembly, so that this cannot go over the minimum gas ignition's temperature, which classifies the area with the explosion's risk.

Dust and debris accumulated on the actuator will slow down its cooling and contribute to the increase of its external temperature.

### 6.2 Allowed Fluid Types

Inert Gas, Sweet Dry natural Gas.

### 6.3 Expected Lifetime

Expected lifetime greater than 25 years, in normal service conditions and with planned maintenance.

## 7. Handling and Lifting

**⚠ Only trained and experienced personnel should handle/lift the actuator.**

The actuator is supplied packed on pallets suitable for normal handling.

**⚠ Actuator could be shipped in horizontal position. In case the actuator has been shipped in horizontal position it is necessary to restore gas-oil connections before start-up. Refer to paragraph "GAS-OIL TANK CONNECTIONS RESTORATION" for details.**

**⚠ Handle the actuator with care. Never stack pallets.**

### 7.1 Lifting Recommendations

- The lifting device and the sling must be suitably rated for the actuator weight and dimensions
- Do not use damaged sling(s)
- The sling must not be shortened with knots or bolts or any other makeshift device
- Do not use hydraulic piping or electric cabling for lifting purposes
- Do not drill holes, weld eye bolts or add any other type of lifting device on the actuator external surface
- Do not lift the actuator and valve combination with the actuator lifting lugs. Only lift the actuator/valve assembly using the valve lifting lugs.
- Every assembly must be estimated separately for a safe and correct lifting
- Avoid pulls or abrupt movements during lifting. Avoid pushing the load
- During lifting operations, do not handle the slings and/or the actuator

### 7.2 Lifting Instructions

**NOTE: Indication of weight, center of gravity, lifting points are reported within specific project documentation.**

**Consult project specific documentation before lifting.**

- Prior to lifting the actuator, remove electrical power and vent all pressure vessels
- Place the textile eye slings as shown in Fig 7.1
- Hook an additional chain sling on the gas/oil tanks support lifting plate

**⚠ The actuator must remain horizontal; balance the load.**

- If the actuator is equipped with a backup or reference tank, hook a chain on the additional lifting lug on the rear bracket
- Angle  $\beta$  must be between  $0^\circ$  and  $45^\circ$  as shown in Fig 7.2



Fig 7.1 Lifting

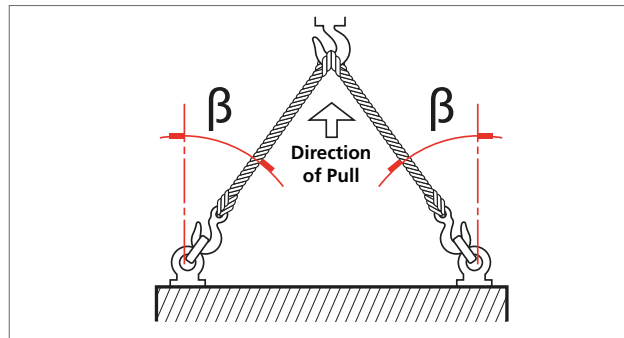

Fig 7.2 Lifting angle



## 8. Storage

---

Rotork actuators are fully tested before leaving the factory.

In order to keep actuator in good condition until installation, at least the following measures are recommended:

- Check presence and assembling of dust plugs
- Store in a dry, well-aired place. Avoid long-term direct exposure to sunlight
- Keep the actuator on shipping pallet until installation

**⚠ Never put the actuator directly on the ground.**

- Protect the valve coupling area (adapter flange and coupling joint, etc.) with rust preventive oil e.g. Mobilarma LT or equivalent
- Protect against weather action, covering the actuators with appropriate polyethylene sheets
- Check the actuator condition every 6 months and verify the above protection measures remain in place

**⚠ Remove package only at the installation time.**

**⚠ Actuator vent ports must be protected with polyethylene sheet to prevent water ingress during storage.**

## 9. Long Term Storage

---

If long term storage is necessary, further operations must be carried out to maintain the actuator in a good working condition:

- Replace the plastic plugs with metal plugs
- Store in a dry, well-aired place. Avoid long-term direct exposure to sunlight
- Stroke the actuator every 12-months:
  - Cycle the actuator (using nitrogen gas with purity level >99,999%) to the working pressure indicated on the name plate
  - Cycle the actuator with all the existing controls (i.e. two complete strokes - one Open, one Closed) at least 5 times
  - Cycle the actuator fitted with the hydraulic manual override by means of the hand pumps for 4 complete strokes
  - Disconnect the pipeline gas and electric (if present) supply from the actuator, and carefully close all the threaded connections of the actuator
- Remove electrical components covers (if present) to ensure control terminals are clean and free from oxidation and humidity. Reassemble the covers
- In case of storage for over 12 months prior to installation, it is recommended to operate the actuator to verify correct operation

## 10. Installation on Valve

Before proceeding, read and understand the Health and Safety information.

**Note: The valve should be properly secured prior to perform following operations according to instructions provided by the Valve's Manufacturer.**

 **Prior to performing any operations check the operating drawings and TAG numbers.**

Consult Rotork for any additional information.

### 10.1 Preliminary Actions

 **Verify the ATEX classification of the actuator is compatible with the plant zoning. Refer to actuator nameplate.**

- The gas over oil tanks must be in the vertical position
- The centreline of the cylinder is usually aligned to the centreline of the associated pipe work
- Ensure all fasteners are adequately tightened, to avoid loosening during operation, taking into account the vibrations induced by the dynamics of the pipeline
- Piping used to provide pipeline gas power to the actuator must be free from contaminants and debris. Ensure tubing runs are adequately fastened and supported to minimize repetitive stress induced the dynamics of the pipeline
- Ensure there are no leaks from any pipeline gas connections. Tighten as required

### 10.2 Instructions

The assembling can be performed by:

- Mounting directly using the actuator housing flange with threaded holes
- Using an adapter and a coupling joint between the actuator and the valve

The assembly position of the actuator must be in accordance with the actuator design, plant requirements and the valve model.

In order to assemble the actuator onto the valve, proceed as follows:

- Verify the coupling dimensions of the valve flange and stem; they must meet the actuator coupling dimensions
- Set the valve in the closed position. The actuator is supplied in the closed position. Check the position of the actuator by means of the position indicator on the center body or on the limit switch (if present)
- Clean the coupling flange of the valve and remove anything that might prevent adherence to the actuator flange. Grease shall be completely removed
- Lubricate the valve stem with oil or grease, to facilitate assembling

- Lift the actuator according to Handling and Lifting instructions (section 7)
- If possible, place the valve stem in a vertical position to facilitate assembling - in this case the actuator must be lifted while the coupling flange is kept in the horizontal position
- If the assembly is done using an adapter and a coupling joint, assemble the coupling joint onto the valve stem before proceeding with the assembly of the actuator
- Do not exert any force while lowering the actuator onto the valve

Installation must be performed by qualified personnel.

 **Hands must be kept away from the coupling area.**

- Fix the actuator to the valve by means of threaded connections (bolts, stud bolts and nuts)
- Tighten the bolts or the nuts of the connecting stud bolts to the correct torque, in accordance with the size and material characteristics of the bolts installed by the customer

 **Support the actuator until full installed and fixing bolts are correctly tightened.**

 **Attention: Do not pressurize the actuator/valve adapter.**

- Check for possible damage to the paint-work and repair if necessary, according to painting specification

## 11. Removal from Valve

The end user is in charge of removing the actuator from the valve.

**⚠ Removal shall be performed only by qualified staff, wearing/using appropriate personal protection devices.**

**⚠ Do not remove the actuator if the valve is blocked in the intermediate position. Contact Rotork customer service.**

In order to disassemble the actuator from the valve, proceed as follows:

- Cut off the gas and electrical power supply
- Vent any storage tanks (if present)
- Remove the gas supply pipe from the actuator
- Release any pressure from the control group
- Vent the gas circuit according to instructions in Circuit Gas Venting (section 12.11)
- Remove control and signal lines from electrical components
- Sling the actuator according to Handling and Lifting instructions (section 7)
- Unscrew bolts or nuts from the stud bolts fixing the actuator to the valve
- Lift and remove the actuator from the valve



Fig 11.1 Actuator / valve assembling example

## 12. Operation

The following instructions must be followed and integrated into end user safety program when installing and using Rotork products. Read and save all instructions prior to installing, operating and servicing this product.

Follow all warnings, cautions and instructions marked on and supplied with the product.

**Install equipment as specified in Rotork installation instructions and as per applicable local and national codes of practice. Connect all products to the proper pipeline gas sources.**

When replacement parts are required, ensure that the qualified service technician uses only replacement parts specified by Rotork.

Substitutions will invalidate any hazardous area certification and may result in fire, electrical shock, other hazards or improper operation.

### 12.1 Description

The gas over oil GO series actuator is a double acting hydraulic actuator, designed to use pipeline gas as the motive power source to pressurize the oil in the actuator.

The main components of a gas over oil actuators are shown in Fig 12.1, Fig 12.2, Fig 12.3 and Fig 12.4.

Table 1: GO Parts list

IT	DESCRIPTION	QTY
1Z3	Gas/Oil tank (closed)	1
1Z4	Gas/Oil tank (Open)	1
1A1(2)	Center body Closure group	1
1A1(1)	Center body	1
1A1(3)	Hydraulic cylinder	1
1Z7	Hydraulic Override Pump	2
1V11	Gas Control	1
1S1	Limit switch box	1
1V17	Solenoid valves (OPEN)	1
1V18	Solenoid valves (CLOSE)	1

**(\*): Gas control could be of different types according to project specific requirements. Refer to Fig 12.2 and Fig 12.3 according to specific project documentation.**

Main components of a gas over oil actuator are:

- hydraulic double acting actuator
- gas control (\*)
- gas/oil tanks
- hydraulic override

Use only control devices supplied by Rotork.

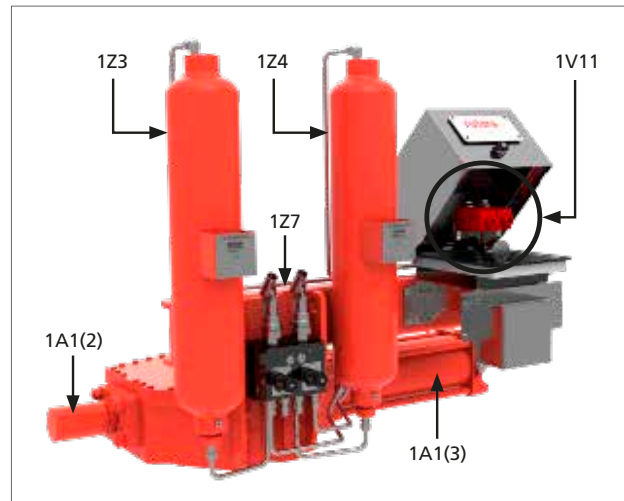

Fig 12.1 Gas Over Oil Main Components (1 of 2)

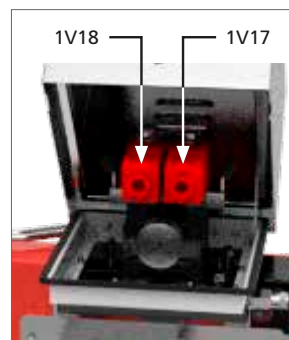

Fig 12.2 Gas Control (Type 1)

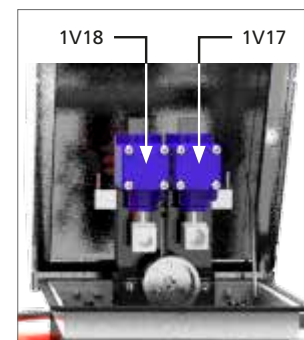

Fig 12.3 Gas Control (Type 2)

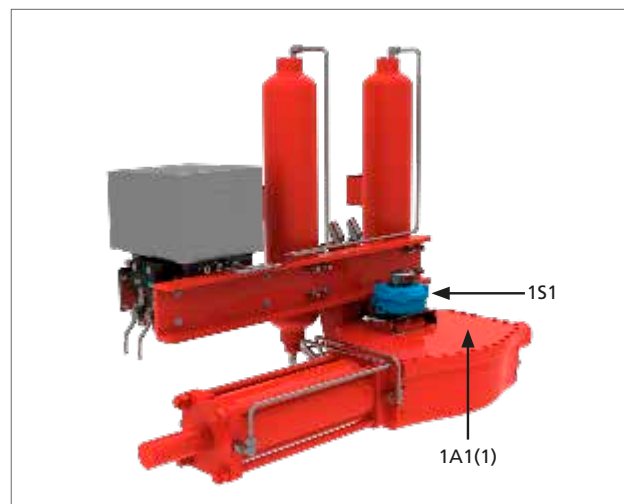

Fig 12.4 Gas Over Oil Main Components (2 Of 2)

## 12. Operation

### 12.2 Operating Description

After being filtered, gas flows into one of the gas/oil tanks through the control valves (gas block), depending on the direction of the stroke (Open or Close).

Hydraulic oil contained in the tank is pressurized by gas and flows into the respective actuator cylinder chamber, while the oil contained in the other chamber flows into the second tank. These actuators are also fitted with a hydraulic emergency manual override operated using two hydraulic hand pumps.

**⚠ Gas-over-oil actuators exhaust power supply gas into the atmosphere during normal operation. This may present an unacceptable hazard in some applications.**

For further details refer to Operating Diagram supplied for the specific application.

### 12.3 Angular Stroke Setting

**⚠ Certain valves incorporate their own stops. For such valves, it is recommended that the actuator stop bolt positions coincide with the valve stop position. Contact the valve manufacturer to set the valve mechanical stops.**

**⚠ Do not use the actuator outside  $90^\circ \pm 5^\circ$  operating range.**

The angular stroke is set by adjusting the stop bolts screwed into the end flange of the hydraulic cylinder and in the center body closing flange.

**⚠ An incorrect setting of angular stroke could cause damages to actuator, valve and/or to personnel.**

#### 12.3.1 Closed Valve Position Setting

Adjust the stop bolt located in the end flange of the hydraulic cylinder (see Fig 5.8), as follows:

- Pressurize the cylinder until the actuator reaches the fully closed position
- Check where the actuator angular stroke stops. It should stop right at the fully closed position of the valve
- To change the stop position:

Remove the cap nut (5) and SealWasher/O-ring (2).



Loosen stop nut (3).



- Pressurize the cylinder (moving the valve towards the opening position); the piston will move away from stop bolt (1)
- If the actuator did not reach the fully closed position:

Adjust the stop bolt (1) anti-clockwise.

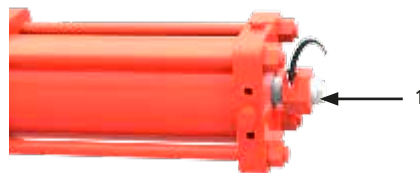

- If the actuator stopped beyond the fully closed position:

Adjust the stop bolt (1) clockwise.



## 12. Operation

- Verify the newly obtained angular position with one closing stroke
- Repeat this operation until the desired angle is obtained

**NOTE: During this operation, it is normal to lose a small amount of oil through the thread of the stop bolt (1).**

- Hold stop bolt (1) with a wrench and tighten stop nut (3). Verify seal washer/o-ring (2) is properly placed

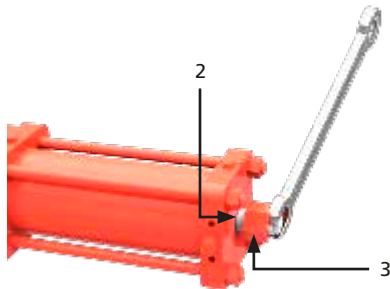

- Insert the seal washer/o-ring between the stop nut and the cap nut. The seal washer/o-ring (2) must be properly centered in the machined recess in the cap nut
- Hold the stop nut (3) with a wrench and tighten the cap nut (5)

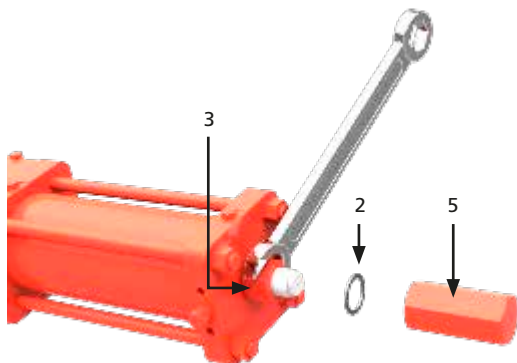

### 12.3.2 Open Valve Position Setting

Adjust the stop bolt located in the center body closing group.

- Pressurize the cylinder until the actuator reaches the fully open position
- Check where the actuator angular stroke stops. It should stop right at the fully open position of the valve
- To change the stop position:

Remove the cap nut (5) and seal washer/o-ring (2).

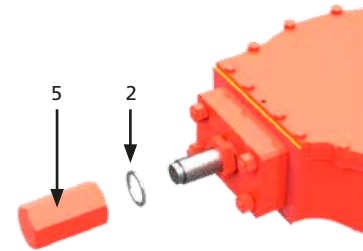

Loosen stop nut (3).

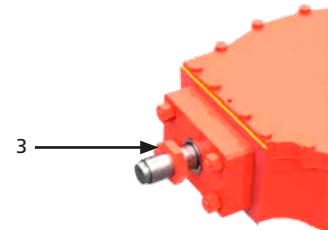

- Pressurize the cylinder (moving the valve towards the closing position); the piston will move away from stop bolt (1)
- If the actuator did not reach the fully open position:

Adjust the stop bolt (1) anti-clockwise.

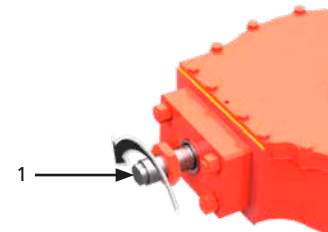

- If the actuator stopped beyond the fully open position:

Adjust the stop bolt (1) clockwise.

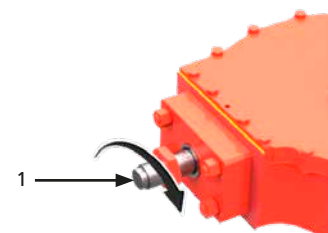

## 12. Operation

- Verify the newly obtained angular position with one closing stroke
- Repeat this operation until the desired angle is obtained
- Hold stop bolt (1) with a wrench and tighten stop nut (3). Verify seal washer (2) is properly placed

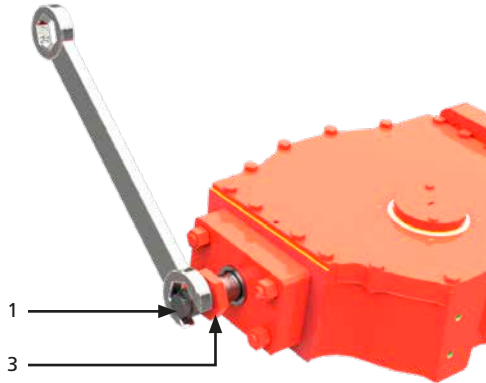

- Insert the seal washer between the stop nut and the cap nut. The seal washer (2) must be properly centered in the machined recess in the cap nut
- Hold the stop nut (3) with a wrench and tighten the cap nut (5)

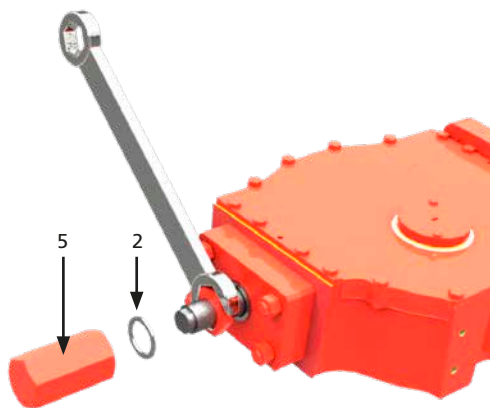

### 12.4 Limit Switch Setting

In case the actuator is provided with limit switches, their setting should be done by the user during the actuator testing operations on the valve.

The limit switches must be set so that they are actuated slightly earlier than the actuator angular stroke is stopped by the mechanical stops.

**⚠ Before performing any operation on electric components, read and follow the safety precautions reported in the Manufacturer's Maintenance Manual. Risk of temporary modification of the component protection.**

**⚠ Switch off the power supply prior to removing cover from the limit switch box.**

- Remove the box cover

#### 12.4.1 Closing Limit Switch

- Place the actuator/valve in the fully closed position
- Disengage the close limit cam
- Rotate the close limit cam until the closing switch is active
- Engage the cam into the splined retainer

#### 12.4.2 Opening Limit Switch

- Place the actuator/valve in the fully open position
- Disengage the open limit cam
- Rotate open limit cam until the opening switch is active
- Engage the cam into the splined retainer

**NOTE: Where 3 or more limit switches are fitted, move the actuator to the extra signaling position(s) and set the cams for each location.**

- Cycle the valve CLOSED and OPEN several times to ensure proper calibration
- Reassemble the box cover, verifying the cover seal is correctly positioned
- Turn the cover shaft manually, aligning it to the switch box shaft, and engage it
- Verify if the position indicator correctly indicates the valve position
- Reconnect power supplies

For more information refer to the limit switch manufacturer's literature.



Fig 12.5 Typical limit switch box

## 12. Operation

### 12.5 Flow Regulator Setting

Flow regulators on Manual Override are regulated in factory according job specific stroking time(s).

In case it is necessary a fine regulation, the following actions should be performed:

- Remove the flow regulator caps by manually unscrewing them (see Fig 12.6)
- Rotate the flow regulators (see Fig 12.7), by means of an Allen key, clockwise to lower the flow rate
- Rotate the flow regulators by means of an Allen key, counter-clockwise to increase the flow rate
- Stroke the actuator to verify stroking time(s)
- Perform the previous tuning until reaching the required stroking time(s)

**⚠ Do not tighten flow regulators completely close: problem of loss of actuator functionality.**

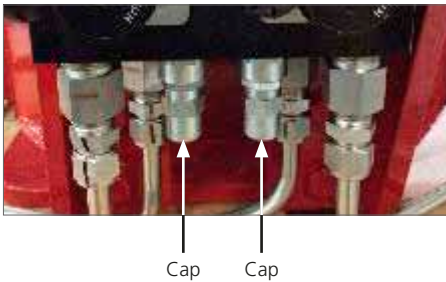

Fig 12.6 Flow regulator cap removal

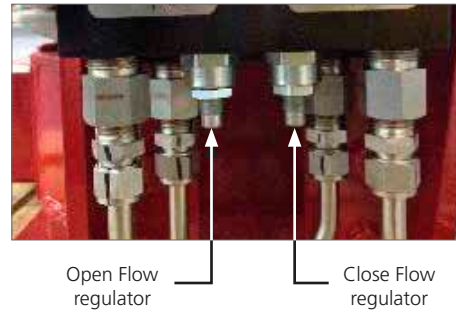

Fig 12.7 Flow regulator, front view

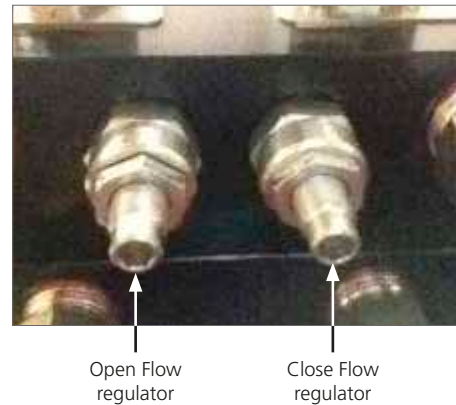

Fig 12.8 Flow regulator, bottom view



## 12. Operation

### 12.6 Pipeline Gas Power Supply

Verify allowed supply pressure range on actuator label.

**⚠ Verify medium composition. Contact Rotork to check the compatibility with supply medium.**

### 12.7 Connection To Pipeline

Preliminary Operations

- Verify sizes of pipes and fittings according to applicable plant specifications
- Clean the inside of the connection pipes by washing them with a suitable detergent and by blowing air into them
- The connecting pipes must be properly shaped and fixed to prevent stress or loosening of threaded connections

**NOTE: For tapered-thread fluid connections, apply a thin layer of thread sealing product (Loctite 577 or equivalent) to ensure a good seal.**

**⚠ Connect the pipeline gas power source in accordance to the applicable operating diagram, please refer to specific job for details.**

If isolation valve(s) are not present on the actuator, the end user should install valve(s) with locking facility at the main actuator gas connection port(s).

The connection to the pipeline gas supply depends on the specific operating diagram, a few examples are shown in the following pictures:

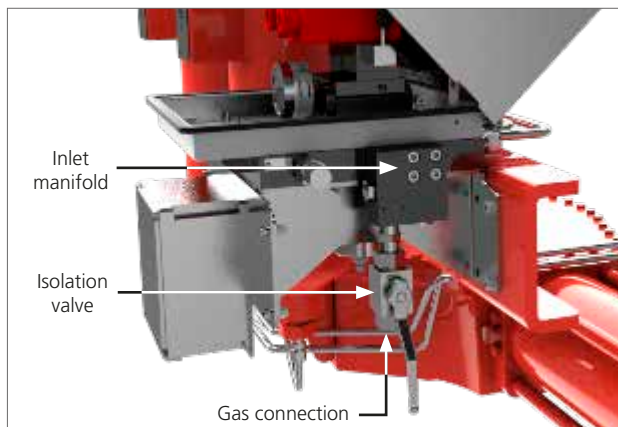

Fig 12.9 Single main supply

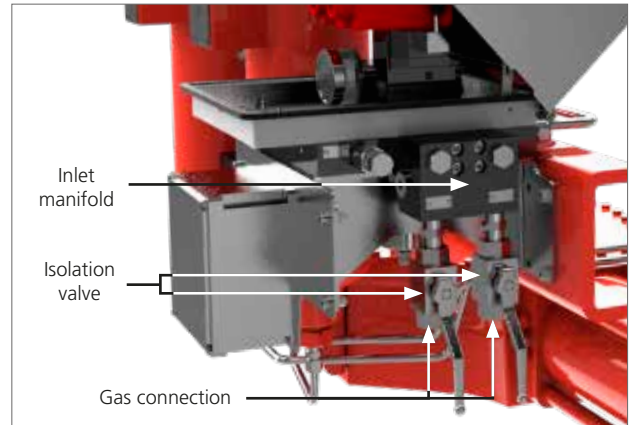

Fig 12.10 Double main supply

**NOTE: Between the main line and the actuator, the minimum suggested conductor outside diameter is 12 mm (at user's care).**

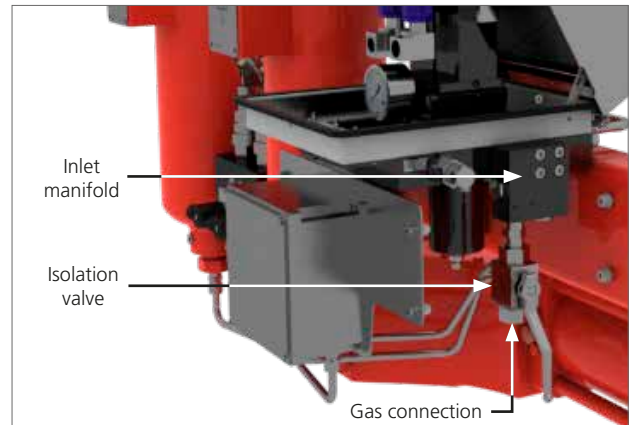

Fig 12.11 Single main supply

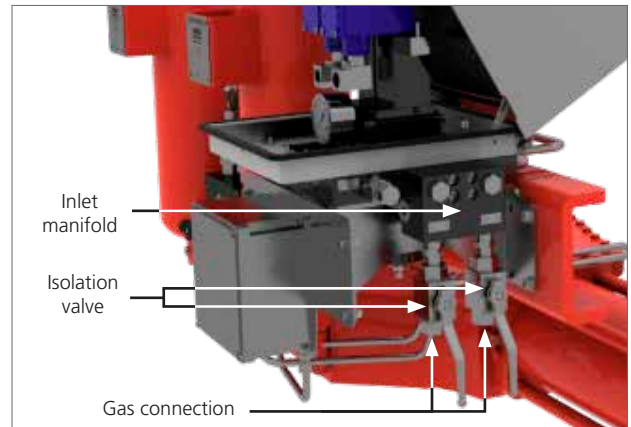

Fig 12.12 Double main supply

## 12. Operation

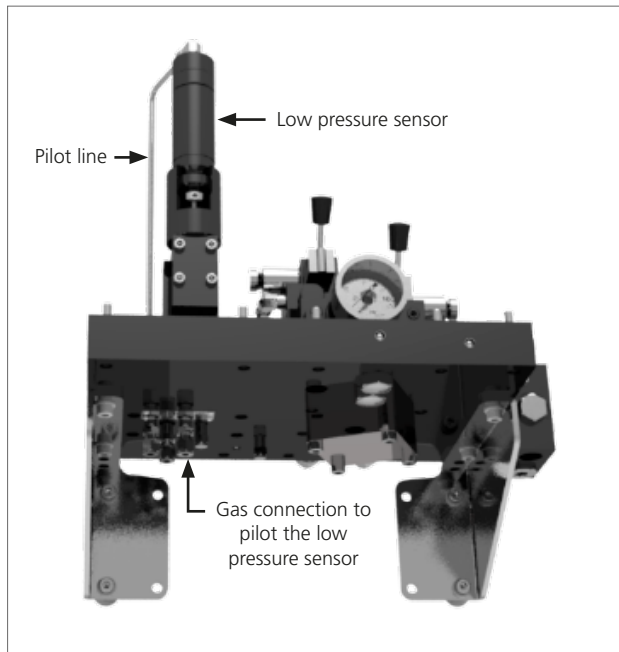

Fig 12.13 Low pressure sensor connection

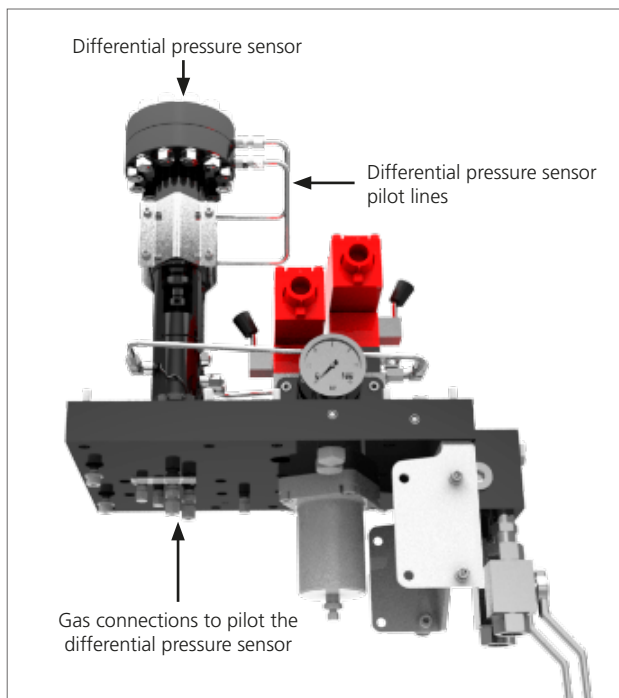

Fig 12.14 Adjustable pilot differential connection

Refer to specific operating diagram for specific application configuration.

### 12.8 Electrical Connections

**⚠ Check electrical components supply voltage, before start-up.**

**⚠ Access to live electrical conductors is forbidden in hazardous areas unless done under a special permit. Otherwise, all power should be isolated and the unit moved to a non-hazardous area for repair.**

**⚠ Prevent electrostatic charges in potentially explosive areas.**

Electrical connection can be performed as follows:

- Remove power supply
- Remove the plastic protection plugs from the cable entries
- Use only appropriately certified reduction fittings, cable glands, fittings and explosion-proof cables
- The cable glands must be tightened in the threaded inlets, to guarantee the waterproof and explosion proof protection
- Pay attention to the correct installation of the o-rings of the cable glands to prevent water and debris infiltration inside electric components
- The size of the electric supply cable must suit the electric power demand
- Insert the connection cables through cable glands and perform assembly according to the cable gland manufacturer's instructions
- Connect the cable wires to the terminal blocks in accordance with the applicable wiring diagram
- Electric connections must be made by using rigid conduits and trailing cables to prevent mechanical stresses in the cable entries
- On the unused entries of the junction box, replace the plastic plugs with approved metal plugs, in order to guarantee sealing and to comply with explosion safety protection codes
- Assemble the covers of the electric components, paying attention to seals
- Once connections have been completed, check electrical components functionality

**⚠ Actuator and electrical components must be protected from electrical sparks, lightning, magnetic or electro-magnetic fields, at user's care.**

## 12. Operation

### 12.9 Start Up

During the start-up of the actuator, it is necessary to check if:

- The oil level in the gas/oil tanks is in accordance with the instructions in **PM-GO2-008** (section 16)
- Gas supply pressure is as prescribed
- The feed voltage values of electrical components (solenoid valves coils, limit switches, pressure switches etc., if applicable) are as prescribed
- Actuator controls such as remote control, local control, emergency control etc. (if applicable) work properly
- Input remote signals are correct
- The setting of control unit components is according to the plant requirements
- Gas/hydraulic connections show no leakage. If necessary, tighten fittings
- The painted parts have not been damaged during transport, assembling or storage operations. On the contrary, after having removed rust, repair the damaged parts following the applicable painting specifications
- Actuator and all of its parties work as expected
- Operating time is in accordance with requirements

**⚠ The end user must guarantee equal voltage potential between the valve and the actuator and provide appropriate grounding. The final user shall indicate and maintain the grounding connections on the actuator.**

### 12.10 Gas-Oil Tank Connections Restoration

If actuator has been shipped in horizontal position it is necessary to restore the gas oil tank connections, before operating the actuator, according to the following instructions:

- Remove metal plug (4) from tubing.
- Remove metal plug (3) from fitting (1)
- Connect the tubing to the fitting (1)



Fig 12.15 Fitting exploded view



Fig 12.16 Metal plugs

While connecting the tube to the tank fitting, particular attention must be paid to the correct positioning of the ferrule inside the conical seat of the fitting.

The tube end and the fitting axis must be co-axial.

- Tighten nut (2)

Once nut (2) has been tightened to the fitting, perform the pneumatic tests and verify the absence of leakages.

Verify the oil level in the gas oil tank and refill if necessary.

After these operations, remove the label (see Fig 12.17).

**BEFORE ACTUATOR COMMISSIONING PLEASE  
REFERS TO PUB017-004 OR PUB017-005  
(AVAILABLE ON WWW.ROTORK.COM)**

Fig 12.17 Label to be removed after gas connection restoration

## 12. Operation

### 12.11 Circuit Gas Venting

In some occasions, example for maintenance, it could be necessary to drain the hydraulic circuit and vent the gas present in the system.

Follow the subsequent instructions:

- Remove electric power supply
- Isolate the isolation valve(s) of pipeline gas supply, moving to closing position

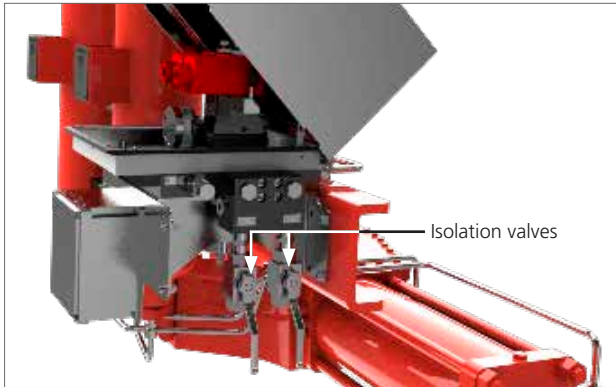

- Isolate the isolation valve(s) of eventual Backup tank and line break tank (if present)
- Empty the backup tank (if present) and the Line Break tank (if present) opening the drain valve(s)
- Act on solenoid local/remote command several times, according to the following indication:
  - Actuator in Open position: act on opening solenoid local/remote command
  - Actuator in Closing position: act on closing solenoid local/remote command

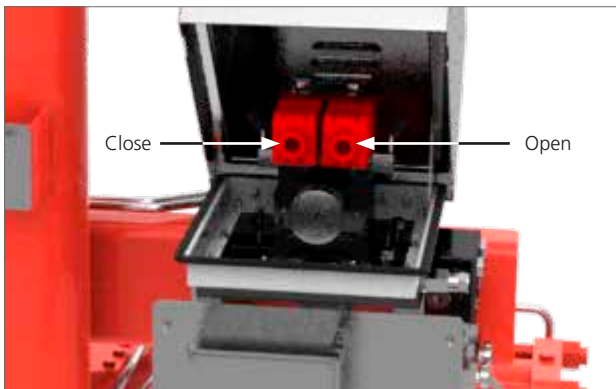

- Continue commuting solenoid valve from local/remote command until pressure gauge indicate 0 barg and no more gas discharging noise is heard

**⚠ Verify all gas is vented before proceeding with any further operation.**

After gas venting and all other operations have been performed, restore initial conditions:

- Close vent valves of backup tank and Line break tank (if present)
- Open the isolation valves of pipeline gas supply

### 13. Dismantling and Disposal

---

Prior to dismantling the actuator, check if any of its parts are still under pressure. The main pressure gauge on the gas block must indicate 0 barg.

- Verify that the backup tank (if applicable) is depressurized otherwise slowly open the drain valve
- Verify that the reference tank (if applicable) is depressurized otherwise slowly open the drain valve
- Verify that the local/remote selectors are in the remote position
- Discharge the oil from the gas/oil tank following PM-GO2-009 (section 16)

 **Used hydraulic fluid must be disposed of safely in accordance with the local environmental laws and regulations.**

- Dismount the actuator, separate and divide the various parts and components according to the type of material
- Dispose of the pieces of steel, cast iron and aluminum alloys as metal scraps
- Dispose of the rubber, PVC, resins etc. separately, in accordance with the existing national and regional regulations
- Electric components are to be separately disposed of on specialized disposal sites

Actuators manufactured after 1993 year do not contain asbestos or its by-products.

### 14. Rotork Sales and Service

---

If your Rotork actuator has been correctly installed and sealed, it will give years of trouble-free service. Should you require technical assistance or spares, Rotork guarantees the best service in the world. Contact your local Rotork representative or the factory direct at the address on the nameplate, quoting the actuator type and serial number.

Some actuators have a special spare parts list. Refer to the project specific documentation for further details.

## 15. Troubleshooting

ID	FAILURE	POSSIBLE CAUSES	CORRECTIVE MEASURES
1	Missed valve actuation (by local controls)	• No gas supply	• Open the isolation valve on the supply gas line
		• Gas filter clogged (if present)	• Clean the gas filter according to <b>PM-GO2-006</b> (section 16)
		• Hydraulic mechanical oil filter clogged	• Clean the mechanical oil filter according to <b>PM-GO2-010</b> (section 16)
		• Flow regulator closed	• Adjust the flow regulator according to Flow Regulator Setting instructions (section 12.5)
		• Failure of local selector	• Contact Rotork customer service
		• Failure of the gas block	• Contact Rotork customer service
		• Low supply pressure	• Restore the supply pressure
		• Torque limit device undue intervention (if applicable)	• Contact Rotork customer service
		• Valve fault	• Consult the valve manufacturer's documentation
2	Missed valve actuation (by remote control)	• Pipe work blocked, crushed or leaking	• Clean or repair as necessary
		• No electrical supply	• Restore the electrical supply
		• No gas supply	• Open the isolation valve on the supply gas line
		• Gas filter clogged (if present)	• Clean the gas filter according to <b>PM-GO2-006</b> (section 16)
		• Hydraulic mechanical oil filter clogged	• Clean the mechanical oil filter according to <b>PM-GO2-010</b> (section 16)
		• Flow regulator closed	• Adjust the flow regulator according to Flow Regulator Setting instructions (section 12.5)
		• Failure of solenoid valve	• Contact Rotork customer service
		• Failure of the gas block	• Contact Rotork customer service
		• Low supply pressure	• Restore the supply pressure
3	Missed valve actuation (by manual override)	• Torque limit device undue intervention (if applicable)	• Contact Rotork customer service
		• Valve/actuator fault	• Consult the valve manufacturer's documentation • For actuator guidance refer to GH Installation and Maintenance Manual (PUB011-007)
		• Pipe work blocked, crushed or leaking	• Clean or repair as necessary
		• Incorrect position of the hydraulic selector manual/remote	• Position the selector, related to the operation to be performed, in "Manual" mode and action the related pump
		• Failure of the hydraulic selector manual / remote	• Contact Rotork customer service
		• Hydraulic mechanical oil filter clogged	• Clean the mechanical oil filter according to <b>PM-GO2-010</b> (section 16)
		• No gas supply	• Open the isolation valve on the supply gas line
		• Oil under the allowed level	• Refill oil

## 15. Troubleshooting

ID	FAILURE	POSSIBLE CAUSES	CORRECTIVE MEASURES
3	Missed valve actuation (by manual override)	• Flow regulator Closed	• Adjust the flow regulator according to Flow Regulator Setting instructions (section 12.5)
		• Hand Pump relief valve undue intervention	• Contact Rotork customer service
		• Valve/actuator fault	• Consult the valve manufacturer's documentation • For actuator guidance refer to GH Installation and Maintenance Manual (PUB011-007)
		• Pipe work blocked, crushed or leaking	• Clean or repair as necessary
4	Low stroking time	• Low supply pressure	• Restore the correct value of the supply pressure
		• Hydraulic mechanical oil filter clogged	• Clean the mechanical oil filter according to <b>PM-GO2-010</b> (section 16)
		• Incorrect flow regulator setting	• Adjust the flow regulator to increase the flow rate (section 12.5)
		• High valve/actuator torque	• Consult the valve manufacturer's documentation • For actuator guidance refer to GH Installation and Maintenance Manual (PUB011-007)
		• Presence of gas within the hydraulic circuitry	• Discharge and replace oil in the hydraulic circuit according to <b>PM-GO2-009</b> (section 16)
		• Oil under the allowed level	• Refill oil
		• Pipe work blocked, crushed or leaking	• Clean or repair as necessary
5	Fast stroking time	• High supply pressure	• Restore the correct value of the supply pressure
		• Incorrect flow regulator setting	• Adjust the flow regulator to reduce the flow rate (section 12.5)
6	Incorrect valve position	• Incorrect setting of mechanical stops	• Check mechanical stop bolts position and adjust if necessary (section 12.3)
		• Incorrect signal from limit switches	• Check limit switches position (section 12.4)
7	Leakage	• Worn seals	• Replace seals according to <b>PM-GO2-013</b> (section 16)
		• Valve/actuator fault	• Consult the valve manufacture's documentation • For actuator guidance refer to GH Installation and Maintenance Manual (PUB011-007)
8	Incorrect pressure indication by pressure gauge	• Pressure gauge fault	• Change Pressure gauge according to procedure <b>CM-GO2-001</b> (section 16)

**For other problems, please contact Rotork.**

## 16. Periodic Maintenance

Rotork recommends performing the following checks to help comply with the rules and regulations of the country of final installation:

**⚠ Remove pipeline gas supply before proceeding with maintenance operations, discharge accumulators or tanks, except where otherwise indicated.**

### Periodic Maintenance Schedule

MAINTENANCE ACTIVITY	PERIODICITY		REFERENCE
	Months	Years	
Visual check of external components and control groups	6		
Verify welding. In case of anomalies contact RFS	6		
Verify control group cover is closed and locked	6		
Check pneumatic connections for leaks. Tighten pipe fittings as required	-	1	
Cleaning	-	1	PM-GO2-001 page 25
Visual check of painting. Verify absence of damages. Repair if necessary according to painting specification	-	1	
Functional test	-	1	PM-GO2-002 page 26
Check electrical components and grounding connections	-	1	PM-GO2-003 page 27
Functional test by manual override	-	1	PM-GO2-004 page 28
Discharge gas dehydrator condensate	6	-	PM-GO2-005 page 29
Cleaning of gas filter	-	1	PM-GO2-006 page 30
Gas dehydrator filter elements replacement (if applicable)	-	1	PM-GO2-007 page 31
Check oil level in gas/oil tank	-	1	PM-GO2-008 page 32
Replace oil in gas/oil tank	-	5	PM-GO2-009 page 33
Clean the hydraulic mechanical oil filter of GO tank	-	5	PM-GO2-010 page 39
Clean the line break gas filters (if applicable)		1	PM-GO2-011 page 41
Clean the close limit valve gas vent (if applicable)		1	PM-GO2-012 page 42
Restore setting of line break (if applicable). Test using the test kit		3	
Restore setting of Low pressure sensor (if applicable)		3	
Cylinder seals replacement	-	5	PM-GO2-013 page 43



### Corrective Maintenance Task

In case of fault, according to details in section 15, the following operations could be executed by the end user.



MAINTENANCE ACTIVITY	REFERENCE
Replace the pressure gauge on gas control	CM-GO2-001 page 47





## 16. Periodic Maintenance

PM-GO2_ATEX / IECEx-001		Page: 1/1
<b>Component:</b> Gas over oil actuator	<b>Task:</b> Cleaning	
<b>Equipment, Tools, Materials:</b> Air compressor Project documentation (design and operating pressure values)	<b>Warnings:</b> 	
<b>Preliminary Operations:</b>		
<b>Description:</b>  <b>Remove pipeline gas supply before proceeding.</b> 1. Remove dust from actuator external surface by dust rag and by blowing air  <b>Do not polish / rub non metal surfaces with a dry cloth. The tools and cleaning procedures must not produce sparks or create adverse conditions in the environment during maintenance operations, so as to prevent potential explosion hazards. Prevent electrostatic charges in potentially explosive areas.</b>		

## 16. Periodic Maintenance

PM-GO2_ATEX/IECEX-002		Page: 1/1
<b>Component:</b> Gas over oil actuator	<b>Task:</b> Functional test	
<b>Equipment, Tools, Materials:</b> Chronometer Project documentation (required stroke times)	<b>Warnings:</b> 	
<b>Preliminary Operations:</b>		
<b>Description:</b> <b>NOTE: Actuator must be connected to the pipeline gas power supply to perform the following test.</b> <ol style="list-style-type: none"><li>1. Operate the actuator.</li><li>2. Perform the stroke several times by local and remote (if applicable) control</li></ol> <p> <b>Actuator exhausts medium supply in the atmosphere during normal operation. Wear PPD including breathing device in function of type of medium supply used.</b></p> <ol style="list-style-type: none"><li>3. Verify actuator is correctly working</li><li>4. Note the stroke time(s)</li><li>5. Verify stroke time(s) are as required</li></ol> <p>In case of stroke times out of required range refer to Troubleshooting ID 4, 5 (section 15) to restore.</p>		

## 16. Periodic Maintenance

PM-GO2_ATEX/IECEX-003		Page: 1/1
<b>Component:</b> Gas over oil actuator (electrical components)	<b>Task:</b> Check electrical components and grounding connections	
<b>Equipment, Tools, Materials:</b> Project documentation	<b>Warnings:</b> 	
<b>Preliminary Operations:</b>		
<b>Description:</b>  <b>Switch off electric power supply before working on electrical devices.</b> <b>Read and follow the safety precautions reported in the Manufacturer's Maintenance Manual.</b> <b>Risk of temporary modification of the component protection.</b>  <b>Use only antistatic clothes.</b> <ol style="list-style-type: none"> <li>1. Remove cover from electric components</li> <li>2. Check electric device components</li> <li>3. Verify tightness of terminal blocks</li> <li>4. Verify absence of humidity and oxidation</li> <li>5. Check cable gland seals</li> <li>6. Verify grounding connection and restore if necessary</li> </ol>		

## 16. Periodic Maintenance

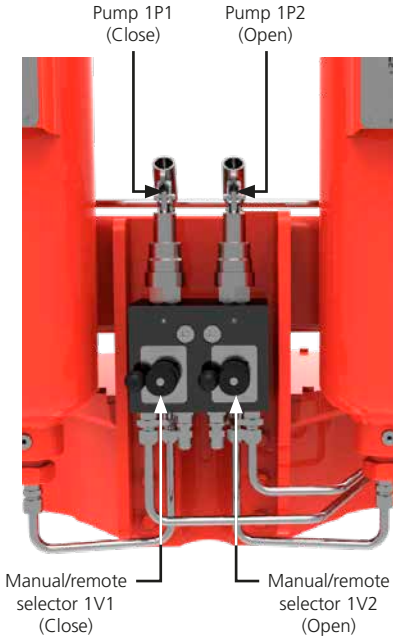
PM-GO2_ATEX/IECEX-004		Page: 1/1
<b>Component:</b> Manual override	<b>Task:</b> Manual override functional test	
<b>Equipment, Tools, Materials:</b> Project documentation	<b>Warnings:</b> 	
<b>Preliminary Operations:</b>		
<b>Description:</b>		
<b>Opening operation</b>		
<ol style="list-style-type: none"><li>1. Verify the actuator is not in the completely Open position</li><li>2. Move the manual / remote selector (1V2) to "manual" and the manual / remote selector (1V1) to "remote"</li><li>3. Operate the pump (1P2) until the actuator reaches the fully Open position</li></ol>		
<b>Closing operation</b>		
<ol style="list-style-type: none"><li>4. Verify the actuator is not in the completely closed position.</li><li>5. Move the manual / remote selector (1V1) to "manual" and the manual / remote selector (1V2) to "remote"</li><li>6. Operate the pump (1P1) until the actuator reaches the fully closed position</li><li>7. Move both manual / remote selectors to the "remote" position</li></ol>		
		

## 16. Periodic Maintenance

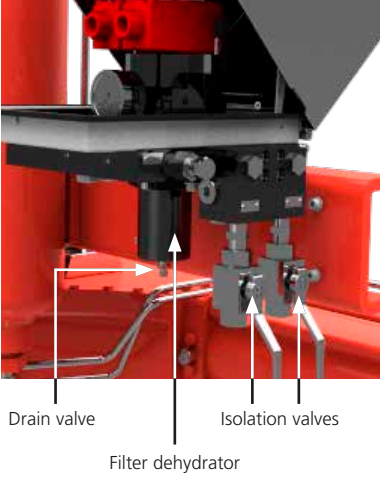
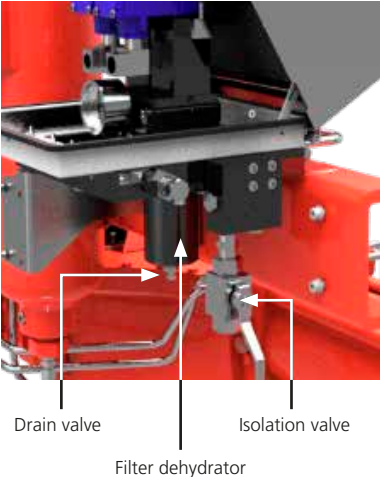
PM-GO2_ATEX / IECEx-005		Page: 1/1
<b>Component:</b> Dehydrator gas filter	<b>Task:</b> Discharge gas dehydrator condensate	
<b>Equipment, Tools, Materials:</b> Project documentation Wrench (10 mm)	<b>Warnings:</b> 	
<b>Preliminary Operations:</b> Circuit Gas Venting (section 12.11)		
<p><b>Description:</b></p> <p><b>⚠ Remove the gas supply to prevent unintentional operation. Move the isolation valve(s) on the supply gas line (supplied by RFS or by end user) to the closed position. Lock the valve to prevent unintentional opening.</b></p> <p>Consult project specific documentation.</p> <ol style="list-style-type: none"> <li>1. Vent the gas circuit according to instructions in Circuit Gas Venting (section 12.11)</li> <li>2. Carefully loose the screw of the drain valve and drain the condensate</li> <li>3. When all condensate has been ejected, tighten the screw</li> <li>4. Open the isolation valve on the supply gas line</li> </ol> <p>Refer to Fig 16.1 (A or B according to project specific application).</p>		
<div style="text-align: center;"> <p><b>A</b></p>  <p>Drain valve                      Isolation valves</p> <p>Filter dehydrator</p> </div> <div style="text-align: center; margin-top: 20px;"> <p><b>B</b></p>  <p>Drain valve                      Isolation valve</p> <p>Filter dehydrator</p> </div> <p style="text-align: center;"><b>Fig 16.1 Filter dehydrator</b></p>		

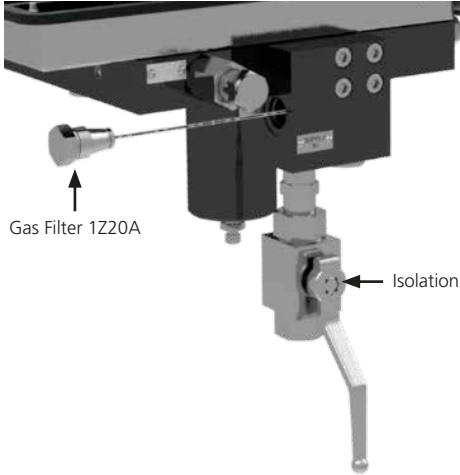

## 16. Periodic Maintenance

PM-GO2_ATEX/IECEX-006		Page: 1/1
<b>Component:</b> Mechanical gas filter	<b>Task:</b> Cleaning of gas filter	
<b>Equipment, Tools, Materials:</b> Wrench (22 mm) Project documentation	<b>Warnings:</b> 	
<b>Preliminary Operations:</b> Circuit Gas Venting (section 12.11)		
<b>Description:</b> <b>⚠ Remove the gas supply to prevent unintentional operation. Move the isolation valve(s) on the supply gas line (supplied by RFS or by end user) to the closed position. Lock the valve to prevent unintentional opening.</b> Consult project specific documentation. <ol style="list-style-type: none"><li>1. Vent the gas present in the system according to instructions in Circuit Gas Venting (section 12.11)</li><li>2. Ensure that there is no gas pressure in the circuit The pressure gauge must show 0 barg</li><li>3. Unscrew gas filter (1z20a/b) (position and number of filters vary in case of manifold with 1 inlet or 2 inlets), using the wrench</li><li>4. Clean the filter with compressed air</li><li>5. Check if the filter o-rings are in a good condition; otherwise replace them</li><li>6. Lubricate the o-ring with a grease film (section 18.1)</li><li>7. Reassemble the gas filter</li><li>8. Open the manual valve on the supply gas line</li></ol>		
		<p>Isolation valves</p> <p>Gas Filters: 1Z20A, 1Z20B</p>
		<p>Gas Filter 1Z20A</p> <p>Isolation valve</p>

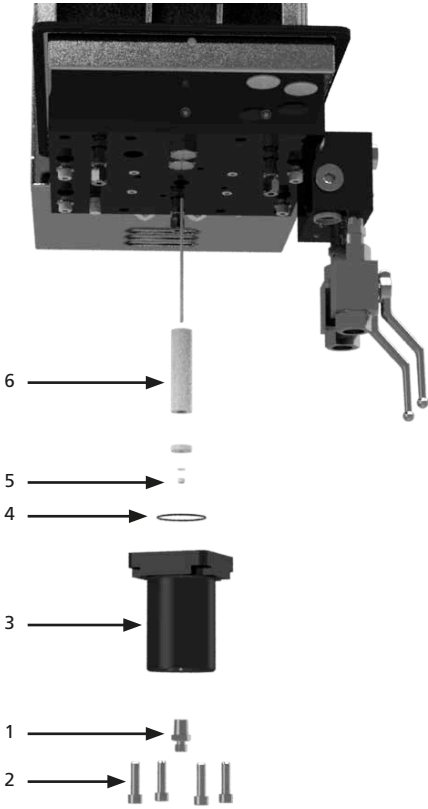
## 16. Periodic Maintenance



PM-GO2_ATEX / IECEx-007		Page: 1/1
<b>Component:</b> Dehydrator gas filter	<b>Task:</b> Gas dehydrator filter elements replacement (if applicable)	
<b>Equipment, Tools, Materials:</b> Air compressor Project documentation Wrench (16 mm) Allen wrench (6 mm)	<b>Warnings:</b> 	
<b>Preliminary Operations:</b> Circuit Gas Venting (section 12.11)		
<b>Description:</b>		
<p><b>⚠ Remove the gas supply to prevent unintentional operation. Move the isolation valve(s) on the supply gas line (supplied by RFS or by end user) to the closed position. Lock the valve to prevent unintentional opening.</b></p> <ol style="list-style-type: none"> <li>1. Vent the gas present in the system according to instructions in Circuit Gas Venting (section 12.11)</li> <li>2. Ensure that there is no gas pressure in the circuit The pressure gauge must show 0 barg</li> <li>3. Unscrew four hex socket bolts (2)</li> <li>4. Remove bowl (3)</li> <li>5. Unscrew bolt (5)</li> <li>6. Remove filter element (6)</li> <li>7. Clean bowl and drain valve (1)</li> <li>8. Replace filter elements (6) and screw bolt (5) into the body</li> <li>9. Check o-ring (4) is in good conditions, otherwise replace it</li> <li>10. Lubricate o-ring with a thin grease layer (section 18.1)</li> <li>11. Reassemble the bowl with flange (3) and fix them screwing bolts (2)</li> <li>12. Tighten drain valve (1)</li> <li>13. Open the manual valve on the supply gas line</li> </ol>		
		

## 16. Periodic Maintenance

PM-GO2_ATEX/IECEX-008		Page: 1/1
<b>Component:</b> Gas/oil tank	<b>Task:</b> Check oil level in gas/oil tank	
<b>Equipment, Tools, Materials:</b> Project documentation Allen wrench (6 mm)	<b>Warnings:</b> 	
<b>Preliminary Operations:</b> Circuit Gas Venting (section 12.11)		
<b>Description:</b>		
<p><b>⚠ Remove the gas supply to prevent unintentional operation. Move the isolation valve(s) on the supply gas line (supplied by RFS or by end user) to the closed position. Lock the valve to prevent unintentional opening.</b></p> <p><b>NOTE:</b>  <b>Actuator in the closed position:</b> the oil level in the close tank must be at minimum value while the oil level in the open tank must be at maximum value.            Verify on the job specific operating diagram the configuration of gas/oil tanks.</p> <p><b>Actuator in the Open position:</b> the oil level in the open tank must be at minimum value while the oil level in the close tank must be at maximum value.            Verify on the job specific operating diagram the configuration of gas/oil tanks.</p> <ol style="list-style-type: none"> <li>1. Move the actuator to the fully Closed position</li> <li>2. Vent the gas present in the system according to instructions in Circuit Gas Venting (section 12.11)</li> <li>3. Ensure that there is no gas pressure in the circuit. The pressure gauge must show 0 barg</li> <li>4. Unscrew and remove the plug with the dip stick on the close gas/oil tank (1Z3) and check the oil level</li> <li>5. In case the oil level is below the minimum, add oil to restore the minimum level (section 18.2) and screw the dip stick plug back</li> <li>6. Unscrew and remove the plug with the dip sticks on the open gas/oil tank (1Z4) and check the oil level</li> <li>7. In case the oil level is below the maximum, add oil to restore the maximum level (section 18.2) and screw the dip stick plug back</li> <li>8. Insert and tighten the dipstick plugs</li> <li>9. Close the storage tank (if present) isolation valves</li> <li>10. Close the drain valve of backup tank and line break tank (if presents)</li> <li>11. Open the manual valve on the supply gas line</li> </ol>		
		

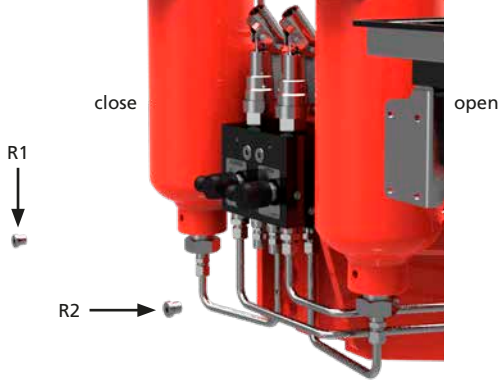

## 16. Periodic Maintenance

		PM-GO2_ATEX / IECEx-009	Page: 1/6
<b>Component:</b> Gas/oil tank	<b>Task:</b> Replace oil in gas/oil tank		
<b>Equipment, Tools, Materials:</b> Container for used oil collection Oil Project documentation	<b>Warnings:</b> 		
<b>Preliminary Operations:</b>			
<b>Description:</b> <p><b>⚠ Remove the gas supply to prevent unintentional operation. Move the isolation valve(s) on the supply gas line (supplied by RFS or by end user) to the closed position. Lock the valve to prevent unintentional opening.</b></p> <ol style="list-style-type: none"> <li>1. Move the actuator to the fully closed position</li> <li>2. Vent the gas present in the system according to instructions in Circuit Gas Venting (section 12.11)</li> <li>3. Ensure that there is no gas pressure in the circuit. The pressure gauge must show 0 barg</li> </ol>			
<b>Oil discharge</b>			
4. Place containers under drain ports (R1 and R2) to collect the fluid			
5. Unscrew plugs (R1 and R2)			
6. Discharge the oil			
7. Screw plugs (R1 and R2) back in their seats			

## 16. Periodic Maintenance

PM-GO2\_ATEX/IECEX-009

Page: 2/6

8. Place containers under drain ports (R3 and R4)

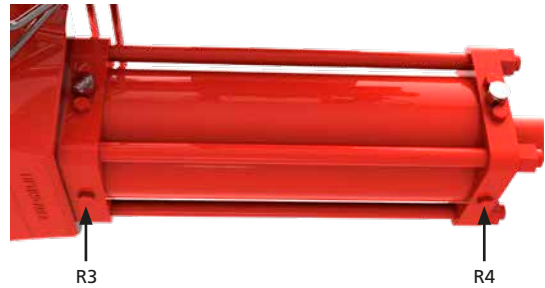

9. Unscrew plugs (R3) and (R4)

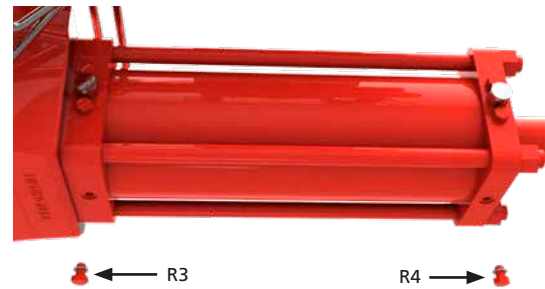

10. Discharge oil from the cylinder

11. Perform the opening/closing stroke through manual override (1P1 and 1P2) to drain the circuit

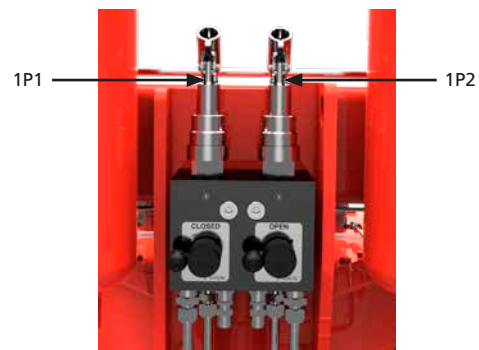



12. Screw R3 and R4 back in their seats



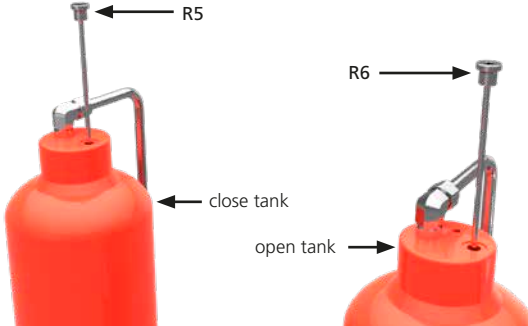

 Used hydraulic fluid must be disposed of safely.

**NOTE:** For tapered-thread fluid connections, apply a thin layer of thread sealing product (Loctite 577 or equivalent).

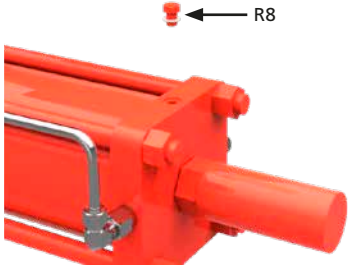

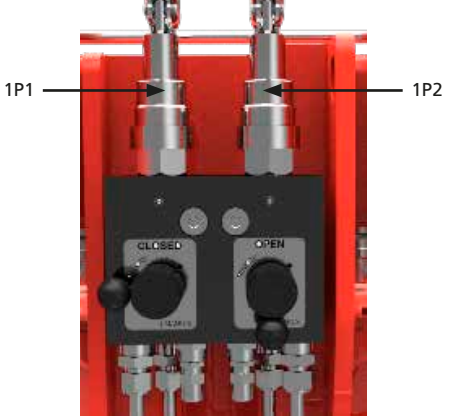
## 16. Periodic Maintenance

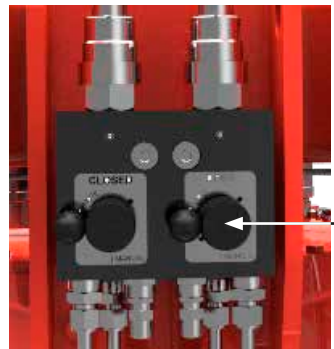
Oil filling	
1. Unscrew and remove plugs with the dip stick R5 and R6	 <p>Diagram illustrating the removal of plugs R5 and R6. R5 is the dip stick, and R6 is the plug. The tank is shown in both closed and open states.</p>
2. Fill in tank (1Z4-open tank) to the max level Important: Do not mix different oils together	 <p>Diagram illustrating the oil tank (1Z4) filled to the maximum level (MAX LEVEL).</p>
3. Place valve (1V2) in the "manual" position	 <p>Diagram illustrating the valve (1V2) in the manual position. The valve is labeled 'CLOSED' and 'OPEN'.</p>
4. Unscrew plug (R8)	 <p>Diagram illustrating the unscrewing of plug (R8) from the device.</p>

Oil filling (cont'd)	
<p>5. Pump (1P2) until oil, free of air bubbles, runs out of hole (R8)</p>	
<p>6. Close plug (R8)</p>	
<p>7. Move the actuator to the Open position acting on pump 1P2</p>	
<p>8. Place valve (1V2) in "remote" position</p>	
<p>9. Check the oil level and fill the tank (1Z4) until minimum level of the dipstick</p>	
<p>10. Fill in tank (1Z3-close tank) to the max level</p>	

## 16. Periodic Maintenance

### Oil filling (cont'd)

11. Place valve (1V1) in "manual" position

1V1

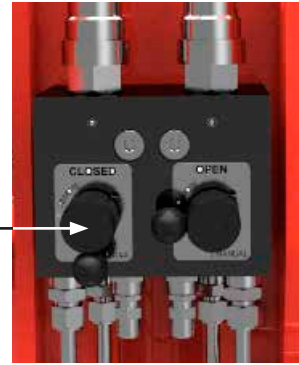

12. Unscrew plug (R7)

R7

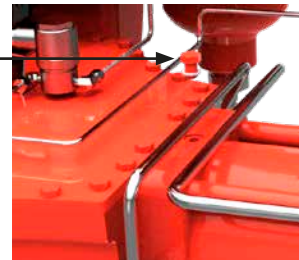

13. Pump (1P1) until oil, free of air bubbles, runs out of hole (R7)



1P1





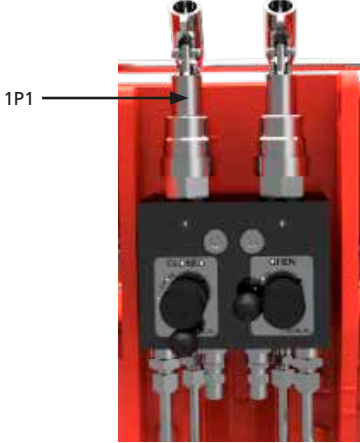

14. Close plug (R7)

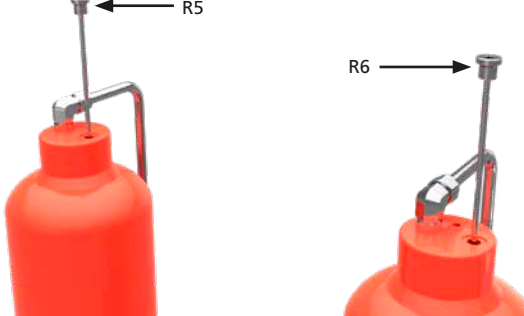
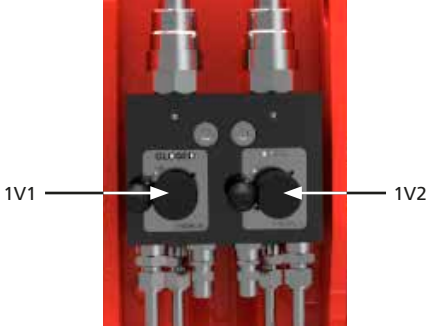
R7

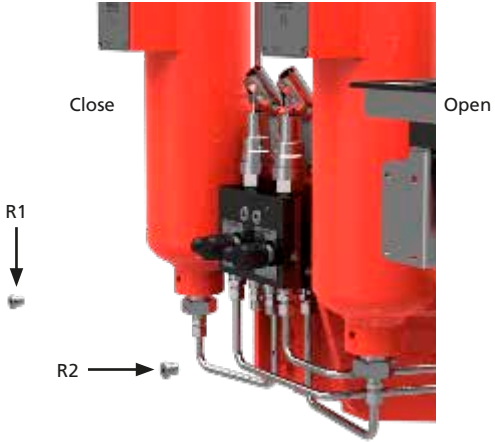

Oil filling (cont'd)	
<p>15. Move the actuator to the closed position, through pump 1P1</p>	
<p>16. Check the oil level in the tank (1Z3) refill to minimum level if necessary</p>	
<p>17. Check oil level in tank (1Z4) is at maximum level and oil level in tank (1Z3) is at minimum level; refill if necessary</p>	
<p>18. Reinstall plug R5, R6</p>	
<p>19. Place valve (1V1) and (1V2) in "remote" position</p>	

## 16. Periodic Maintenance

		PM-GO2_ATEX / IECEx-010	Page: 1/2
<b>Component:</b> GO tank		<b>Task:</b> Hydraulic mechanical oil filter cleaning	
<b>Equipment, Tools, Materials:</b> Air Compressor Allen wrench (6 mm) Wrench (50 mm) Container for oil collection		<b>Warnings:</b> 	
<b>Preliminary Operations:</b> Circuit Gas Venting (section 12.11)			
<b>Description:</b>  <b>Remove the gas supply to prevent unintentional operation. Move the isolation valve(s) on the supply gas line (supplied by RFS or by end user) to the closed position. Lock the valve to prevent unintentional opening.</b> <ol style="list-style-type: none"> <li>1. Move the actuator to the fully closed position</li> <li>2. Vent the gas present in the system according to instructions in Circuit Gas Venting (section 12.11)</li> <li>3. Ensure that there is no gas pressure in the circuit. The pressure gauge must show 0 barg</li> </ol> <b>ATTENTION: this procedure should be executed contextually to PM-GO2-009 (section 16).</b>			
4. Place containers under drain ports (R1 and R2) to collect the fluid			
5. Unscrew plugs (R1 and R2) using the Allen wrench			
6. Disconnect the hydraulic pipe unscrewing the hydraulic connection			

## 16. Periodic Maintenance

PM-GO2\_ATEX/IECEX-010

Page: 2/2

7. Unscrew the filter using the wrench (50 mm)



8. Clean the filter with compressed air  
9. Reinstall the filter. Pay attention to the o-ring  
In case of damages substitute the o-ring  
10. Tighten the filter

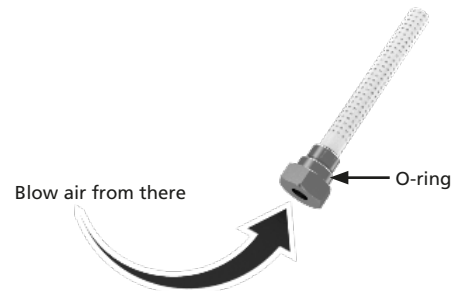

11. Reinstall the hydraulic pipes



12. Reinstall plug R1, R2

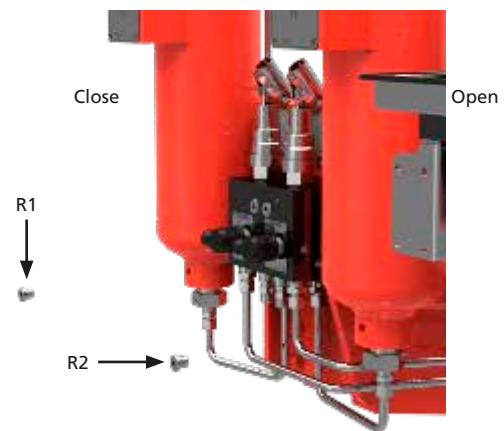



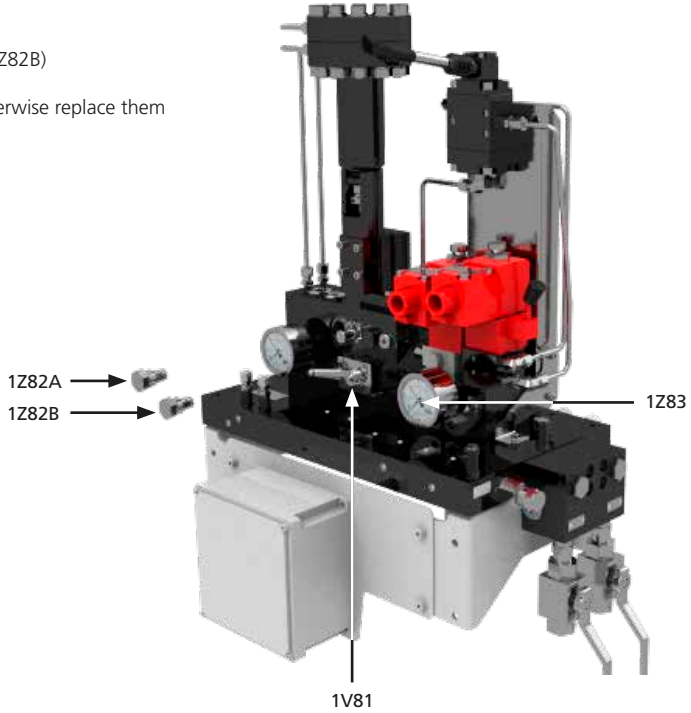

## 16. Periodic Maintenance

PM-GO2_ATEX/IECEX-011		Page: 1/1
<b>Component:</b> Line break	<b>Task:</b> Line break gas filter	
<b>Equipment, Tools, Materials:</b> Compressed air Project documentation Wrench (22 mm)	<b>Warnings:</b> 	
<b>Preliminary Operations:</b> Circuit Gas Venting (section 12.11)		
<b>Preliminary actions</b> <ol style="list-style-type: none"><li>1. Consult project specific documentation</li><li>2. Vent the gas present in the system according to instructions in Circuit Gas Venting (section 12.11)</li><li>3. Pressure gauges must show 0 barg</li></ol>		
<b>Description:</b> <ol style="list-style-type: none"><li>4. Carefully unscrew and remove gas filters (1Z82A and 1Z82B)</li><li>5. Clean the mechanical filters with compressed air</li><li>6. Check if the filters o-rings are in a good condition; otherwise replace them</li><li>7. Lubricate the o-rings with a grease film</li><li>8. Reinstall the gas filters</li><li>9. Close drain valve of the reference gas tank</li><li>10. Open isolation valve (1V81)</li></ol>		
		

## 16. Periodic Maintenance

PM-GO2_ATEX/IECEX-012		Page: 1/1
<b>Component:</b> Close limit valve	<b>Task:</b> Clean the close limit valve gas vent	
<b>Equipment, Tools, Materials:</b> Wrench (16 mm) Compressed air Project documentation	<b>Warnings:</b> 	
<b>Preliminary Operations:</b>		
<b>Preliminary actions</b> 1. Consult project specific documentation		
<b>Description:</b> 2. Remove the ¼" BSP gas vent with a 16 mm wrench 3. Clean the gas vent with compressed air 4. Reinstall the gas vent		
		

## 16. Periodic Maintenance

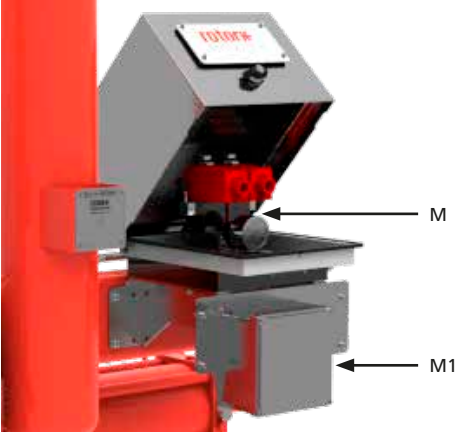
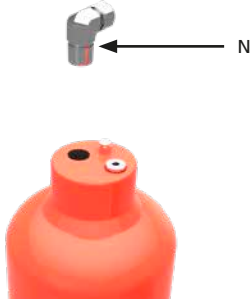
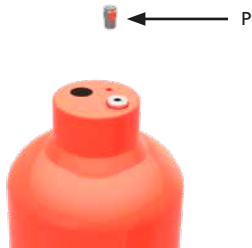
		PM-GO2_ATEX/IECEX-013	Page: 1/4
<b>Component:</b> Gas over oil actuator-hydraulic cylinder		<b>Task:</b> Cylinder seals replacement	
<b>Equipment, Tools, Materials:</b> Spare seals Wrench Lifting tools Project documentation		<b>Warnings:</b> 	
<b>Preliminary Operations:</b> Circuit Gas Venting (section 12.11)		Removal from Valve, PM-GO2-009	
<b>Description:</b>  <b>Remove pipeline gas supply before proceeding</b> <b>Preliminary actions</b> <ol style="list-style-type: none"> <li>1. Vent the gas present in the system according to instructions in Circuit Gas Venting (section 12.11)</li> <li>2. Pressure guage must show 0 bar</li> <li>3. Remove actuator from valve (section 11)</li> <li>4. Position the actuator on a workbench (if possible) or in a stable position</li> <li>5. Move the actuator to the closed position</li> <li>6. Remove the components (e.g., limit switch box, gas storage tank, back-up tank) located on the center body cover, if any</li> <li>7. Discharge oil in gas/oil tank (ref. PM-GO2-009 section 16)</li> <li>8. Remove hydraulic and pipeline gas pipes</li> </ol> <b>Gas block removal</b> <ol style="list-style-type: none"> <li>9. Sustain the gas block (M) with a textile sling</li> <li>10. Unscrew bolts (M1)</li> <li>11. Remove gas block (M)</li> </ol> <b>Gas/oil tanks removal</b> <ol style="list-style-type: none"> <li>12. Remove fitting (N) from oil/gas tanks</li> <li>13. Remove the protection plug (P) from the threaded lifting point</li> </ol>			
			
12. Remove fitting (N) from oil/gas tanks			
13. Remove the protection plug (P) from the threaded lifting point			

## 16. Periodic Maintenance

PM-GO2\_ATEX/IECEX-013

Page: 2/4

14. Screw an eye bolt (Q) into threaded lifting point and sustain the tank adequately

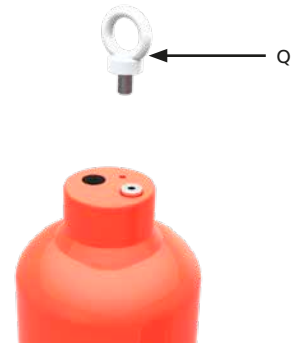

15. Unscrew bolts (S2) and remove the tank from bracket (S)

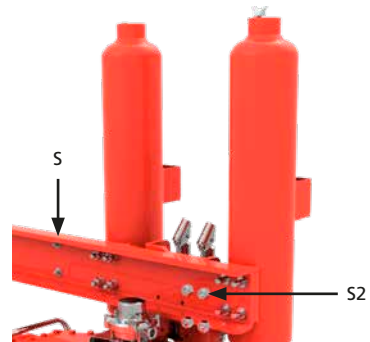

16. Follow the same procedure to remove second gas/oil tank (1Z4)

17. Put the flat webbing slings on bracket (S)  
18. Unscrew bolts (S1)  
19. Remove bracket (S)

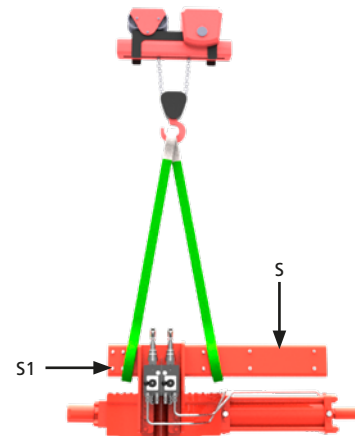

For GH Bare Actuator cylinder seals replacement, refer to GH/S Installation and Maintenance Manual (MM-005-1-E) or GH/D Installation and Maintenance Manual (MM-006-1-E).

## 16. Periodic Maintenance

PM-GO2\_ATEX/IECEX-013

Page: 3/4

### Final reassembly

20. Position bracket (S) and tighten bolts (S1)

**Important:** For tapered- thread fluid connections, apply a thin layer of thread sealing product (Loctite 577 or equivalent) to ensure a good seal

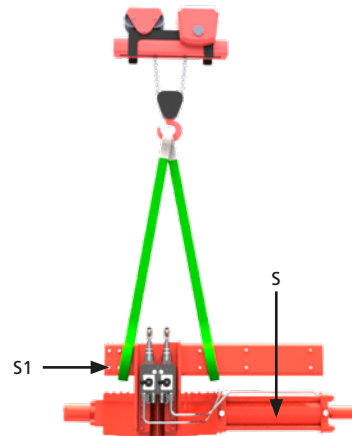

21. Place gas/oil tanks (1Z3 and 1Z4) onto the bracket (S) and fix them screwing the hex bolts (S2)

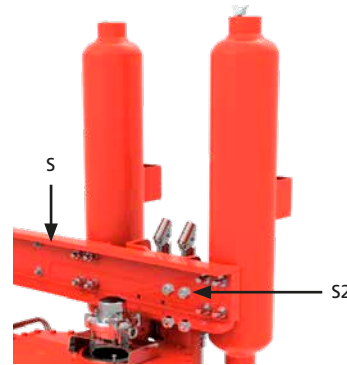

22. Remove eye bolt (Q)

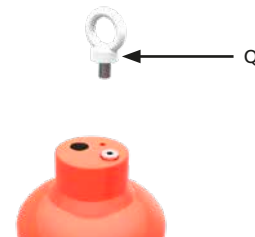

23. Assemble protection plugs (P) into the threaded lifting points of the tanks



24. Reinstall fitting (N) on oil/gas tanks



## 16. Periodic Maintenance

PM-GO2\_ATEX/IECEX-013

Page: 4/4



### Final testing

25. Position gas block (M) and tighten by means of bolts (M1) to bracket (S)
26. Re-install pipeline gas and hydraulic pipes
27. Install the components (e.g., limit switch box, gas storage tank) located on the center body cover if any



28. Fill the oil level in the gas/oil tanks and vent air from the cylinder circuit. Ref. **PM-GO2-009** (section 16)
29. The actuator must be tested before it is assembled on the valve
30. Cycle the actuator several times, using exclusively dry nitrogen gas, to check functionality and absence of leakages
31. Check that the painted parts have not been damaged during disassembly and/or reassembly
32. If necessary repaint them in accordance with the applicable painting specifications
33. The actuator is now ready to be assembled on the valve

## 16. Periodic Maintenance

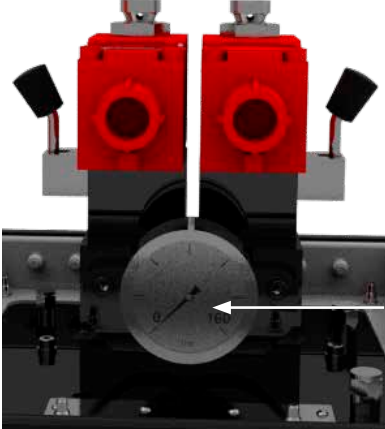
CM-GO2_ATEX/ IECEx-001		Page: 1/1
<b>Component:</b> Gas control	<b>Task:</b> Replace the pressure gauge on gas control	
<b>Equipment, Tools, Materials:</b> Pressure gauge Wrench (14 mm)	<b>Warnings:</b> 	
<b>Preliminary Operations:</b> Circuit Gas Venting (section 12.11)		
<b>Description:</b>  <b>Remove pipeline gas supply before proceeding.</b> <ol style="list-style-type: none"><li>1. Vent the gas present in the system according to instructions in Circuit Gas Venting (section 12.11)</li><li>2. Carefully unscrew the Pressure Gauge</li><li>3. Replace with another one</li><li>4. Tighten the pressure gauge</li><li>5. Connect pipeline gas supply</li><li>6. Verify that Pressure gauge correctly indicate the pressure in the circuit</li></ol>		
		

## 17. Part List

For spare part list, refer to GH Installation and Maintenance Manual (PUB011-007).

## 18. Grease and Hydraulic Oil Specification

In general, there is no need to lubricate the actuator because its mechanism is lubricated -for life. The standard grease and oil for Rotork scotch yoke actuators is shown below. If an alternative was specified and/or supplied, please refer to the job specific documentation.

### 18.1 Grease

The following grease is recommended for lubrication of mechanical components of the scotch yoke for temperature range -20 to +60 °C (-22 to +140 °F):

Manufacturer	DOW CORNING CORPORATION
Trade Name	MOLIKOTE® P40
Colour	CLEAR BROWN
Unworked Penetration (ISO 2137)	310-350 mm/10
Viscosity of Oil at 40 °C (104 °F) (DIN 51 562)	360 mm <sup>2</sup> /s
Service Temperature	-40 to 230 °C (-40 to 446 °F)
Drop Point (ISO 2176)	NONE
Four Ball Tester	
Weld Load (Din 51 350 pt.4)	3000 N
Wear Scar Under 800N Load (Din 51 350 pt.5)	0.94 mm
Coefficient of Friction <sup>1)</sup>	
Screw Test - $\mu$ Thread	0.16
Screw Test - $\mu$ Head	0.08
<sup>1</sup> Coefficient of friction in bolted connection, M12x1.75, 8.8, on blackened surface.	

QUANTITY OF GREASE IN HOUSING	
Center body size	Qty (kg/lb)
065	0.3/066
085	0.3/066
100	0.3/066
130	0.4/088
160/161	0.5/1.10
200/201	0.5/1.10
270/271	0.8/1.76
350	1.2/2.64

The following grease is recommended for lubrication of mechanical components of the scotch yoke for temperature range -46 to +60 °C (-51 to +140 °F):

Manufacturer	MOBIL
Trade Name	MOBILTEMP® SHC100TM
NLGI Grade	2
Colour	CLEAR BROWN
Penetration, Density, Viscosity	
Worked Penetration at 25 °C (77 °F) (ASTM D 217)	280
Viscosity of Oil at 40 °C (104 °F) (ASTM D445)	100 cSt
Temperature	
Drop Point (ASTM D 2265)	>260 °C (>500 °F)
Load-carrying Capacity, Wear Protection, Service Life	
Four Ball Tester (ASTM D 2266)	0.4 mm
Weld Load (ASTM D 2596)	>200
Corrosion Protection (ASTM D6138)	0



## 18. Grease and Hydraulic Oil Specification

### 18.2 Hydraulic Oil

**This is the standard oil specification for Rotork GO actuators working at temperature between -20 to +60 °C (-4 to +140 °F). The same is applied for lubrications of seals and grooves for maintenance purposes.**

Manufacturer	MOBIL
Trade Name	DTE 10 EXCEL 32
ISO Viscosity Grade	32
Viscosity, ASTM D 445	
cSt @ 40 °C (104 °F)	32.7
cSt @ 100 °C (212 °F)	6.63
Viscosity Index, ASTM D 2270	164
Brookfield Viscosity ASTM D 2983, cP @ -20 °C (-4 °F)	1090
Brookfield Viscosity ASTM D 2983 cP @ -30 °C (-22 °F)	3360
Brookfield Viscosity ASTM D 2983 cP @ -40 °C (-40 °F)	14240
Tapered Roller Bearing (CEC L-45-A-99), %Viscosity Loss	5
Density 15 °C, ASTM D 4052, kg/L	0.8468
Copper Strip Corrosion, ASTM D 130, 3 hrs @ 100 °C (212 °F)	1B
Rust Characteristics, ASTM D 665B	Pass
FZG Gear Test, DIN 51534, Fail Stage	12
Pour Point, ASTM D 97	-54 °C (-65 °F)
Flash Point, ASTM D 92	250 °C (482 °F)
Foam Sequence I, II, III, ASTM D 892, ml	20/0
Dielectric Strength, ASTM D877, kV	49
Acute Aquatic Toxicity (LC-50, OECD 203)	Pass

**This is the standard oil specification for Rotork GO actuators working at temperature between -46 to +60 °C (-51 to +140 °F). The same is applied for lubrications of seals and grooves for maintenance purposes.**

Manufacturer	MOBIL
Trade Name	UNIVIS HVI
ISO Viscosity Grade	32
Viscosity, ASTM D 445	
cSt @ 40 °C (104 °F)	13.5
cSt @ 100 °C (212 °F)	5.3
Viscosity Index, ASTM D 2270	404
Kinematic Viscosity @ -40 °C (-40 °F), ASTM D 445	371 cSt
Copper Strip Corrosion, ASTM D 130	1A
Pour Point, ASTM D 97	-60 °C (-76 °F)
Flash Point, ASTM D 92	101 °C (214 °F)

**An alternative oil may have been specified for your application. Please refer to the job specific documentation.**

# rotork®



[www.rotork.com](http://www.rotork.com)

A full listing of our worldwide sales and service network is available on our website.

Rotork plc  
Brassmill Lane, Bath, UK  
tel +44 (0)1225 733200  
email [mail@rotork.com](mailto:mail@rotork.com)

PUB017-005-00  
Issue 02/22

As part of a process of on-going product development, Rotork reserves the right to amend and change specifications without prior notice. Published data may be subject to change. For the very latest version release, visit our website at [www.rotork.com](http://www.rotork.com)

The name Rotork is a registered trademark. Rotork recognises all registered trademarks. Published and produced in the UK by Rotork. POLTG0222