

# rotork®

Keeping the World Flowing  
for Future Generations



## SPI Series Smart Position Indicator



Installation, Operating and Maintenance Instruction Manual



## Contents

---

1. Health and Safety	3
2. Specific Conditions of Use for Hazardous Area Approved Units	4
3. Specifications and Intended Use	4
4. Storage	5
5. Unpacking & Handling	6
6. Installation	6
7. Commissioning	8
8. Operation	10
9. Maintenance	10
10. Special Tools	10
11. Spare Parts	10
12. Torque Tightening Figures	11
13. SPI Approvals	11

## List of Figures

---

1 – SPI Thrust Taking Output Sleeve Assembly	7
2 – SPI Thrust Bearing Arrangement	7
3 – SPI Output Sleeve Machining / Sealing Faces	7
4 – Sealant Location Face	7
5 – SPI Commissioning: Access	8
6 – SPI Commissioning: Adjustable Parts for Ex i Variants	9
7 – SPI Commissioning: Adjustable Parts for Ex e d and Non-Hazardous Area Variants	9

## List of Tables

---

1 – Torque Tightening Figures	11
-------------------------------	----

 **THIS MANUAL CONTAINS IMPORTANT SAFETY INFORMATION. PLEASE ENSURE IT IS THOROUGHLY READ AND UNDERSTOOD BEFORE INSTALLING, OPERATING OR MAINTAINING THE EQUIPMENT.**

## 1. Health and Safety

This manual is produced to enable a competent user to install, operate, adjust and inspect the Rotork SPI Smart Position Indicator. Only persons competent by virtue of their training or experience should install, maintain and repair Rotork equipment.

Under no circumstances should replacement parts be used in this product, other than those supplied or specified by Rotork.

Work undertaken must be carried out in accordance with the instructions in this and any other relevant manuals.

If the product is used in a manner not specified in this manual and any other Rotork manual, the protection provided by this product may be impaired.

The user and those persons working on this equipment should be familiar with their responsibilities under any statutory provisions relating to the health and safety of their workplace. Due consideration of additional hazards should be taken when using this product with other equipment. Should further information and guidance relating to the safe use of Rotork products be required, it will be provided on request.

The electrical installation of this product should be carried out in accordance with the national legislation and statutory provisions relating to the safe use of this equipment, applicable to site of installation.

For the UK: Electricity at Work Regulations 1989 and the guidance given in the applicable editions of the 'IEE Wiring Regulations' should be applied. Also the user should be fully aware of their duties under the Health and Safety Act 1974.

The mechanical installation should be carried out as outlined in this manual and also in accordance with relevant standards such as British Standard Codes of Practice and EN/IEC 60079-14.

If the product has nameplates indicating that it is suitable for installation in hazardous areas then it may be installed in Zone 1 and Zone 2 classified hazardous area locations only. It should not be installed in hazardous area locations with an ignition temperature less than 135°C, unless suitability for lower ignition temperatures has been indicated on the device nameplate.

The product should only be installed in hazardous areas location compatible with the gas groups stated on the nameplate.

The electrical installation, maintenance and the use of the product should be carried out in accordance with the code of practice relevant for that particular hazardous area certification.

No inspection or repair should be undertaken unless it conforms to the specific hazardous area certification requirements. Under no circumstances should any modification or alteration be carried out on the product as this could invalidate its hazardous area approval certification. Access to live electrical conductors is forbidden in the hazardous area unless this is done under a special permit to work, otherwise all power should be isolated and the product moved to a non-hazardous area for repair or attention.

### **WARNING: OPERATION**

The SPI must only be used as intended. Equipment not used in the manner described may lead to excessive risk and the possibility of serious injury or death.

### **WARNING: ELECTRICAL RATING**

Do not exceed electrical ratings stated on the equipment. Failure to adhere to this may lead to the possibility of fire, serious injury or death.

### **WARNING: PROTECTIVE EARTHING**

The equipment must be earthed. Failure to adhere to this may lead to the possibility of fire, serious injury or death.

### **WARNING: ISOLATION**

The equipment must be isolated / de-energised prior to removal of covers / servicing. Failure to adhere to this may lead to possibility of fire, serious injury or death.

### **WARNING: WIRING**

Do not replace any wiring with wiring rated to a lesser rating. Ensure that wiring terminals are correctly integrated into additional wiring circuits with respect to local wiring regulation. The risk associated with connection of terminals is placed solely on the installer. Failure to adhere to this may lead to fire, serious injury or death.

### **WARNING: SERVICE ALTITUDE**

The product installation altitude must be restricted to less than 2000 m as defined by IEC61010-1.

### **WARNING: ENCLOSURE MATERIALS**

Housing, Cover & Body:	Aluminium (anodised)
Optional Thrust Base Body:	Steel
Input & Output Shafts:	Steel
Fasteners:	Stainless Steel
Input Lip Seal:	Nitrile
Shaft Bush:	Steel/Bronze + PTFE

The user must ensure that the operating environment and any materials surrounding the SPI cannot lead to a reduction in the safe use of, or the protection afforded by, the product. Where appropriate the user must ensure the product is suitably protected against its operating environment.

### **WARNING: OPERATING SPEED**

The SPI unit is not designed to be operated by anything other than a hand wheel, as such it must not be operated by any high speed device such as a drill, etc.

## 2. Specific Conditions of Use for Hazardous Area Approved Units

---

1. This equipment incorporates an anodized outer surface. To avoid the possibility of electrostatic charges, cleaning must only be carried out with a damp cloth.
2. The SPI product is only for use in manual applications.
3. In cases where two intrinsically safe proximity sensors are installed the associated circuits are to be considered as separate intrinsically safe circuits, the stated input parameters being applied to each circuit separately.

## 3. Specifications and Intended Use

---

### 3.1 Scope of Use

Rotork SPI units are valve position indicators. They are designed to be mounted to an actuating gearbox, or directly mounted to smaller valves for either non-thrust taking, or with the addition of a thrust base assembly, thrust taking applications.

The unit is designed to mechanically indicate valve position locally, and electrically signal open / close position of the valve to a remote location, as well as transmit the required operating torque to the valve actuating gearbox or valve via an input shaft mounted handwheel.

Rotork products should not be modified in any way nor should any parts be removed without first consulting Rotork. For applications outside of this scope, please contact Rotork. The user alone is responsible for the appropriate use of the SPI in consideration of the basic conditions existing at the plant.

When using this document, also refer to the contract specific general arrangement drawing.

### 3.2 Environmental Specifications

Max Altitude: 2,000m (6,560 ft)

Ambient Temperature: For standard and Ex e d/Ex h and Ex tb product variants:  
-25 to +65 °C (-13 to 149 °F)  
with 1A max current -25 to +40 °C (-13 to 104 °F) with 5A max current

For Ex ib, Ex h product variants:  
-25 to +100 °C (-13 to +212 °F)

Determination of the ambient temperature for the installed product should consider external heat sources, such as process temperatures or solar heating, as appropriate.

Sealing: IP67

Vibration: The product is designed to be installed in a vibration-free environment. If prolonged or severe vibrations are likely, please contact Rotork for advice.

### 3. Specifications and Intended Use

#### 3.3 Electrical Specifications

Max Voltage & Current: For standard variants fitted with micro-switches:  
90 VAC / 15 VDC, 5A

For standard variants fitted with proximity sensors: 8 VDC

For Ex e d/Ex h and Ex tb product variants:  
90 VAC / 15 VDC,  
5A (Tamb to 40°C),  
1.5 A (Tamb to 65°C)

For Ex i, Ex h product variants:  
Ui 16V, li 25 mA, Pi 64 mW  
(per separate IS circuit)

#### 3.4 Operational Specifications

Life: 2 million input shaft turns, each direction

Duty: Manual operation, service as per parent gearbox

Max Operating Rim Effort: 356 N (80 lbs)

Overload Capability: 1.5x rated torque

Direction: Clockwise in – clockwise out

#### 3.5 Functional Specifications

Type	Ratio	Min Turns	Max Turns	Weight / kg
SPI 1	34.8:1	4	26	6.4
SPI 2	113.3:1	13	87	6.4
SPI 3	368:1	42	284	6.6
SPI 4	1196:1	137	923	6.7

Base Mounting: ISO5210 F10

Non-Thrust Valve Shaft Dimensions: Ø20 mm with single 6 mm x 6 mm keyway

Non-Thrust Shaft Engagement: 60 mm

Thrust Taking Valve Stem Dimensions: Machining within a Ø20 mm circle

Thrust Taking Max Stem Engagement: 135 mm

Max Thrust: 40 kN (8992 lb ft.)

Thrust Taking Unit Additional Weight: 3.6 kg

### 4. Storage

SPI units should be stored in a clean and dry environment. They should be protected against condensation inside the packaging. Direct contact with wet timber pallets and packing cases should be avoided. Storage temperature should be between 0 and +40 °C (+32 and +104 °F).

SPI design life is 40 years from manufacture date, inclusive of storage duration.

## 5. Unpacking & Handling

SPI units are packed in a variety of configurations depending upon the application, size of the actuating gearbox mounted to and the quantity of the consignment. Therefore it is the responsibility of the individual unpacking and handling the unit to carry out a risk assessment for the particular consignment and to unpack and handle accordingly using safe working practices. The packaging should be re-used or recycled according to local regulations. The packaging materials used are wood, cardboard, paper, steel and polyethylene. SPI units should be lifted using soft slings (where required) and care should be taken not to apply any shock loads. The individual risk assessment should identify which part of the SPI and or actuating gearbox should be used for lifting. Once the SPI or actuating gearbox combination is fitted to the valve, the assembled valve, gearbox and / or SPI must not be slung from the gearbox or SPI unit.

**⚠ WARNING: Individual weights for actuating gearboxes and SPI units are recorded on their respective nameplates; actuating gearboxes and SPI units may present an unbalanced load.**

**⚠ WARNING: Only trained and experienced personnel should carry out handling. At all times, safe handling must be ensured.**

**⚠ WARNING: Each assembly must be assessed to identify all risks associated with handling.**

**⚠ WARNING: The actuating gearboxes and SPI units must be fully supported until full valve shaft/stem engagement is achieved and the actuating gearbox or SPI is secured to the valve flange.**

**⚠ WARNING: Once connected to the valve, each assembly must be assessed on an individual basis for safe handling / lifting. Never lift the complete combination-valve assembly via the actuating gearbox or SPI.**

## 6. Installation

Should the SPI be pre-mounted to the input flange of an actuating gearbox, please see the relevant installation, operating and maintenance manual for the actuating gearbox for instructions on how to assemble the gearbox to the valve, and continue to section 7 – Commissioning.

Should the SPI be retrofitted to an existing actuating gearbox in the field, please follow the instructions below for SPI installation to a valve for a non-thrust taking application, treating the actuating gearbox input shaft as the valve shaft.

**⚠ WARNING: Once fully torque-tightened, none of the fasteners in the SPI unit should be re-used. All fasteners with the exception of the position indicator plate fasteners (D), electrical cover fasteners (E) and internal cam and cam disc fasteners (H and I) are torque-tightened at the factory. If a fastener is loosened for any reason, then it should be discarded and a new fastener used in its place.**

**⚠ WARNING: The SPI must not be used to carry the combined weight of the actuating gearbox and valve during lifting operations.**

Visually check the SPI for signs of damage during transit or storage. Contact Rotork for advice if more serious damage is observed.

This range of position indicators is supplied to suit the order requirements however, for the optional thrust taking application, unless specifically requested at the ordering stage, the output sleeve will be supplied blank and must be machined to suit the equipment to be operated. See Figure 1 – SPI Thrust Taking Output Sleeve Assembly, Figure 2 – SPI Thrust Bearing Arrangement & Figure 3 – SPI Output Sleeve Machining / Sealing Faces for the removal and re-fitting of the output sleeve.

The output sleeve, thrust bearings and washers can be easily removed from the bottom of the SPI by first removing the spigot ring. The output sleeve machining should be concentric to the outside diameters of the sleeve to ensure correct operation in service. Chamfers should be provided to aid location with the valve spindle. All sharp edges should be removed. Following machining, the output sleeve, thrust bearing assemblies and spigot ring should be re-fitted to the SPI with the output sleeve dogs in the correct position to ensure drive from the SPI output shaft. Applying a thin layer of grease to the faces marked 'A' below will make refitting of the output sleeve easier.

**⚠ WARNING: Ensure the correct order of thrust bearing components. Incorrect fitting of the thrust bearing assemblies may lead to serious damage resulting in significantly reduced performance and life of the SPI unit.**

## 6. Installation

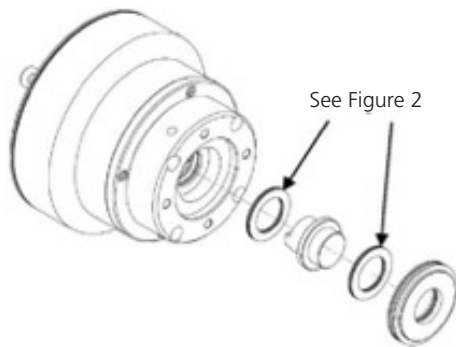

Figure 1 – SPI Thrust Taking Output Sleeve Assembly

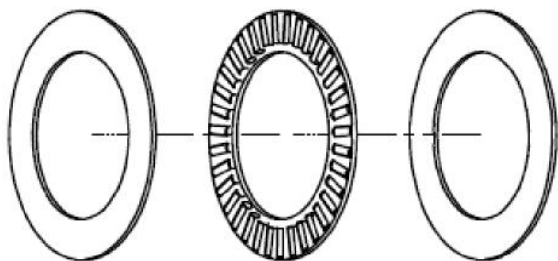

Figure 2 – SPI Thrust Bearing Arrangement

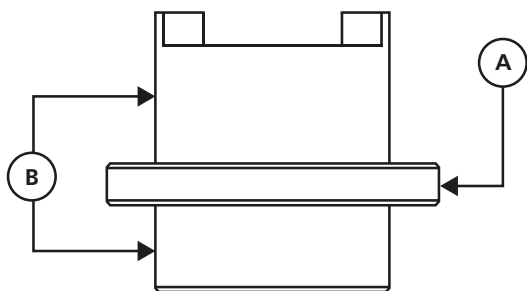

Figure 3 – SPI Output Sleeve Machining / Sealing Faces

### Important Notes for Figure 3 – SPI Output Sleeve Machining / Sealing Faces:

- A:** The surfaces marked "A" can be used for chucking the output sleeve for machining.
- B:** The surfaces marked "B" are sealing faces and must be defect free.

**⚠ WARNING:** Take care when fitting the handwheel to the input shaft to ensure it can be removed again. Commissioning can only be completed by removing and replacing the electrical cover of the SPI, which cannot be achieved with the handwheel fitted.

For non-thrust taking applications, the valve shaft should be given a light coat of suitable grease to aid assembly with the SPI. The SPI should then be fitted by sliding it over the valve shaft (using suitable lifting equipment as required), ensuring the keyway is correctly aligned with the valve shaft. The SPI baseplate should sit square on the valve mounting flange and should not place any sideways forces on the output shaft. If the SPI unit is a tight fit on the valve shaft, it may be necessary to strike the top of the SPI input shaft with a soft faced mallet. Excessive force should not be used and if there is any possibility of damaging the SPI unit, it should be removed, the valve shaft and SPI output shaft bore inspected and any tight spots dressed out where appropriate.

For thrust taking applications, the threaded valve stem must be thoroughly lubricated with a suitable grease before fitting the SPI. The SPI should then be offered up to the valve stem, and the input shaft rotated to thread the output sleeve of the SPI onto the valve stem. The SPI baseplate should sit square on the valve mounting flange and should not place any sideways forces on the output sleeve. If the output sleeve is a tight fit on the valve stem, the SPI unit should be removed, the valve stem and output sleeve machining inspected and any tight spots dressed out where appropriate.

For other valve shaft / stem arrangements, please contact Rotork for further advice on installation of the SPI unit.

**⚠ WARNING:** Do not strike the SPI unit to aid installation for a thrust taking application, as the thrust bearings may become damaged and will require replacing.

The SPI is supplied with studs and nuts for mounting to the valve or gearbox. If it is desired to replace these we recommend grade 8.8 fasteners (640 MPa yield strength). The mounting nuts or screws should be torque-tightened to a maximum of 45 Nm (33.1 lb ft.) for non-thrust taking applications or 60 Nm (44.3 lb ft.) for thrust taking applications.

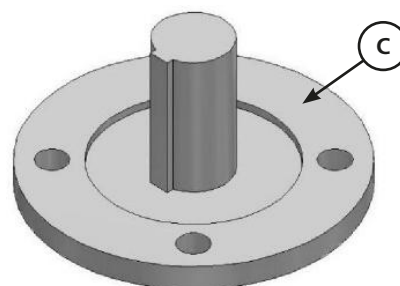

Figure 4 – Sealant Location Face

### Important Note for Figure 4 – Sealant Location Face:

It is recommended that adjoining flanges be sealed on assembly with silicon sealant. The face marked "C" on Figure 4 – Sealant Location Face shows where sealant can be applied to the valve mounting flange.

## 7. Commissioning

**⚠ WARNING: The equipment must be isolated / de-energised prior to removal of covers / servicing. Failure to adhere to this may lead to possibility of fire, serious injury or death.**

1. Remove the handwheel and the 4 small screws "D" attaching the indicator plate to the shaft of the SPI. Remove the indicator plate.
2. Remove the 4 screws "E" attaching the electrical cover to the housing, these will be retained by the cover.
3. Carefully prise the cover away from the housing and remove from the assembly, retaining any grease present on the central lip seal.
4. Remove any plastic transit plugs from the cable entries.

**⚠ WARNING: It is the sole responsibility of the installer to supply and fit the correct cable glands for the application. The cable entries on the SPI unit are tapped 1/2"-14 NPT. Only appropriate entry reducers, glands or conduit, suitably certified and selected in accordance with EN/IEC 60079-14, may be used in hazardous locations.**

**⚠ WARNING: It is the sole responsibility of the installer to supply and fit the correct power/signalling cords, which must be compliant with EN 61010.**

**⚠ WARNING: The product ambient temperature rating may be above 60 °C (depending on the variant). Wiring that is suitable for the expected ambient temperature should be selected.**

5. Run the power/signalling cords, complete with cable glands appropriate to the cable size and type, to the SPI unit, and thread through the 2 cable entries in the side of the housing as required.
6. Connect the ends of the power/signalling cords to the terminals inside the unit, and the earth cable to either the internal or external earth point. Please refer to separate wiring diagram for terminal connections; this is included on the underside of the electrical cover. Connections to the switch terminals are made by inserting a screwdriver to open the spring then inserting the conductor into the spring-cage. The connection can be released in the same way. Connection to the external earth terminal is secured using the supplied M5 pan head screw, connection to the internal earth terminal is secured using the supplied M5 nyloc nut. To ensure a secure electrical connection make sure that the spring washer is compressed. The earth screw tightening torque must not exceed 1.5 Nm (1.1 lb ft / 13.2 lb in).

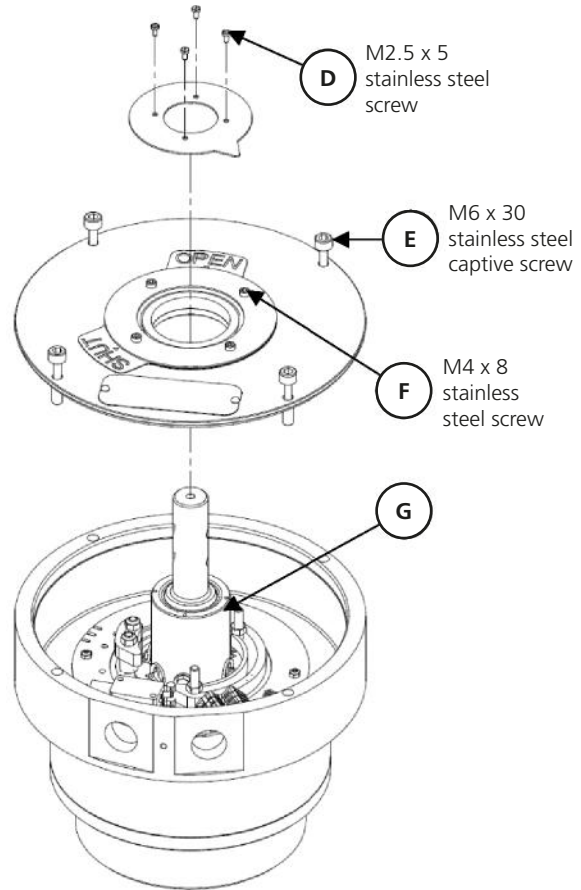

Figure 5 – SPI Commissioning: Access

**⚠ WARNING: When connecting conductors, make sure that the wire insulation extends right up to the terminal point.**

**⚠ WARNING: Earth continuity is assured via the provided earth terminals for the housing components, and via the valve stem or actuating gearbox input shaft for the SPI shaft and handwheel.**

7. Gently pull any excess cord length back through the cable entries, and fit the cable glands to the cable entries, ensuring the cable glands are tight and fully waterproof. Seal unused cable entries with a steel or brass threaded plug. In hazardous areas, an appropriately certified threaded blanking plug must be used.

**⚠ WARNING: Take care when fitting the handwheel to the input shaft to ensure it can be removed again. Commissioning can only be completed by removing and replacing the electrical cover of the SPI, which cannot be achieved with the handwheel fitted.**

8. Refit the handwheel and turn the input shaft of the SPI until the valve is fully closed.
9. For Ex i variants only, check to see if the desired position of the cam fastener is obstructed by the raceway web. If it is, continue through steps 10 to 13, if not, skip to step 14.



## 7. Commissioning

10. Carefully remove the plastic setting ring "H" from the main SPI shaft "G".
11. Loosen the 2 screws "I" holding the cam disc to the shaft and lift the cam disc over the heads of these screws.
12. Rotate the cam disc to one of the other available orientations to allow the cams to be positioned as desired, then replace the cam disc over the screw heads "I" and re-tighten to the prescribed torque.
13. Refit the plastic setting ring "H" over the main SPI shaft "G", ensure to rotate the ring so it seats fully down on the cam disc.
14. Loosen the 2 nuts "J" holding the closed (short) cam onto the cam disc.
15. Slide the closed cam along the raceway until the switch is made, then re-tighten the nuts "J" to the prescribed torque.
16. The open (long) cam "K" is designed so it is possible to continually signal open for valve positions between 60% open and fully open.
  - a. If this feature is desired, turn the input shaft of the SPI to the chosen valve position between 60% open and fully open, and follow steps 14 and 15 to set position of the open cam.
  - b. If this feature is not required, turn the input shaft of the SPI until the valve is fully open, and repeat steps 14 and 15 for the open cam.

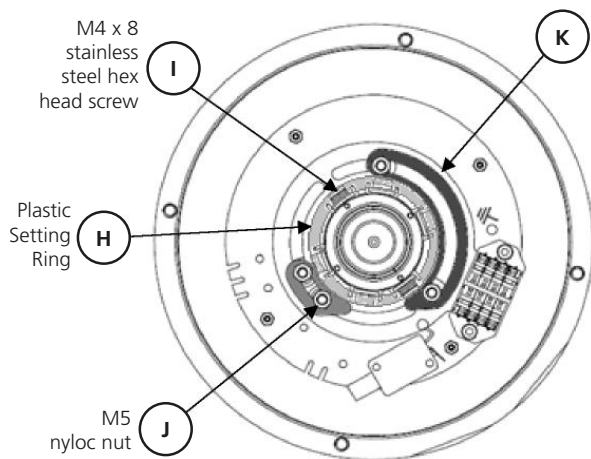

Figure 6 – SPI Commissioning: Adjustable Parts for Ex i Variants

17. For Ex e d and non-hazardous area variants, loosen the 2 grub screws "L" holding the closed (narrow) cam to the main SPI shaft.
18. Slide the closed cam around the main SPI shaft until the switch is made, then re-tighten the grub screws "L" to the prescribed torque.

19. The open (wide) cam "M" is designed so it is possible to continually signal open for valve positions between 60% open and fully open.
  - a. If this feature is desired, turn the input shaft of the SPI to the chosen valve position between 60% open and fully open, and follow steps 17 and 18 to set position of the open cam.
  - b. If this feature is not required, turn the input shaft of the SPI until the valve is fully open, and repeat steps 17 and 18 for the open cam.

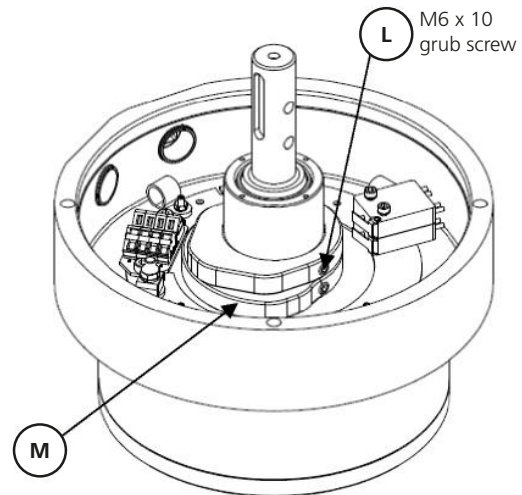

Figure 7 – SPI Commissioning: Adjustable Parts for Ex e d and Non-Hazardous Area Variants

20. Lightly coat the top section of the external diameter of the main SPI shaft "G" with a suitable grease and refit the electrical cover onto the main housing, taking care not to damage the central lip seal or the external diameter O-ring. Secure with the 4 retained screws "E" and tighten to the prescribed torque.
21. Refit the indicator plate to the input shaft, secure with the 4 small screws "D" and tighten to the prescribed torque.
22. Lightly coat the input shaft with a suitable grease (Rotork recommends Fuchs Renolit CLX2 or equivalent) and mount the handwheel. Secure as appropriate for the handwheel design.
23. Loosen the 4 small screws "F" retaining the open / shut plates on the electrical cover enough to allow the plates to slide over each other.
24. Turn the handwheel until the valve is fully open.
25. Position the "OPEN" plate to be in line with the position indicator plate, and lightly tighten a single screw "F" to prevent accidental movement.
26. Turn the handwheel until the valve is fully closed.
27. Loosen the single screw "F" and position the "SHUT" plate to be in line with the position indicator, taking care not to disturb the position of the "OPEN" plate.
28. Re-tighten all 4 small screws "F" to the prescribed torque.

## 8. Operation

---

The SPI is used to transmit the torque developed by a hand wheel in order to achieve the torque and / or thrust requirement of the valve, either directly or through an actuating gearbox, and has been designed for an operating speed of 12 RPM. It is also used to mechanically display valve position locally and to electrically signal open / closed valve position to a remote location. There are no operating instructions relating to the SPI unit itself. The SPI should be operated according to the valve manufacturer's instructions and the actuating gearbox manufacturer's instructions (if fitted).

No running in period is required. Calibration of the unit after initial set up is not required.

**⚠ WARNING: Under no circumstances should any additional lever device such as a wheel-key, wrench or extension bar be applied to the handwheel in order to develop more torque or thrust when closing or opening the valve. This may cause damage to the valve and/or actuating unit or may cause the valve to become stuck in the seated or back-seated position, or could lead to serious injury. This practice must not be undertaken at any time.**

**⚠ WARNING: The SPI unit is not designed to be operated by anything other than a hand wheel and as such has a rated operating speed of 12 RPM. The SPI unit must not be operated with any form of high speed device (such as air tools, drills, etc.) as this may lead to irreparable damage or serious injury.**

## 9. Maintenance

---

All mechanical cavities are lubricated with Fuchs Renolit CLX2 grease and sealed for life. Under normal operating conditions no maintenance is required for the SPI unit.

All fasteners are fully torque tightened during assembly or commissioning. Should the unit require maintenance or repair, it must be returned to Rotork.

This equipment incorporates an anodized outer surface. To avoid the possibility of electrostatic charges, cleaning must only be carried out with a damp cloth.

Under no circumstances is the electrical assembly (comprising of the PCB, soldered terminals, wires and switches/sensors) to be altered, disassembled or replaced. For SPI units certified for use in potentially explosive atmospheres, this assembly is a certified IECEx/ATEX component, and any changes to this component will invalidate the safety certification of the SPI unit.

All seals, housing components and the input and output shafts are safety critical parts for units in hazardous areas.

## 10. Special Tools

---

No special tools are required for the installation or maintenance of the SPI unit.

## 11. Spare Parts

---

As SPI units are sealed and qualified for life, replacement of parts does not extend this qualified life. If an inspection or repair of the SPI unit is desired, only Rotork shall perform the inspection or repair. Where required, Rotork will replace all screws, O-rings, bearings and grease when repairing the SPI unit.

## 12. Torque Tightening Figures

The values for the torque tightening the required fasteners are given in the following table. For all other fasteners not covered below please contact Rotork.

Fastener Size	Torque Tightness (Nm)	Torque Tightness (Lb Ft.)
M2.5	0.5	0.4
M3	1.0	0.7
M4	2.2	1.6
M5	4.5	3.3
M6	7.7	5.7

Table 1 – Torque Tightening Figures

## 13. SPI Approvals

Refer to product nameplate for unit specific approval details.

UK & EU – Hazardous Area	International – Hazardous Area	China – Hazardous Area	International – Non Hazardous
UKEX (2016 No. 1107) ATEX (2014/34/EU)	IEC 60079-0:2011 Ed 6 IEC 60079-1:2007 Ed 6 IEC 60079-7:2006 Ed 4 IEC 60079-11:2011 Ed 6 IEC 60079-31:2013 Ed 2 ISO 80079-36:2016 Ed 1 ISO 80079-37:2016 Ed 1	GB3836.1-2010 GB3836.2-2010 GB3836.3-2010 GB3836.4-2010 GB12476.1-2013 GB12476.5-2013	BS EN 60529
On versions fitted with flameproof micro-switches: Ⓜ II 2GD Ex e d IIC T4 Gb Ex h IIC T4 Gb Ex tb IIIC T135°C Db IP67 T ambient: -25 to +65 °C (@ 1.5 A) or -25 to +40 °C (@ 5 A)	On versions fitted with flameproof micro-switches: Ex e d IIC T4 Gb Ex h IIC T4 Gb Ex tb IIIC T135°C Db IP67 T ambient: -25 to +65 °C (@ 1.5 A) or -25 to +40 °C (@ 5 A)	On versions fitted with flameproof micro-switches: Ex e d IIC T4 Gb Ex h IIC T4 Gb Ex tb IIIC T135°C Db IP67 T ambient: -25°C to +65°C (@ 1.5 A) or -25°C to +40°C (@ 5 A)	IP67
On versions fitted with intrinsically safe proximity sensors: Ⓜ II 2G Ex ib IIC T4 Gb Ex h IIC T4 Gb T ambient: -25 to +100 °C	On versions fitted with intrinsically safe proximity sensors: Ex ib IIC T4 Gb Ex h IIC T4 Gb T ambient: -25 to +100 °C	On versions fitted with intrinsically safe proximity sensors: Ex ib IIC T4 Gb Ex h IIC T4 Gb T ambient: -25 to +100°C	Watertight & Dust-tight T ambient: -25 to +100 °C
Certificate: CSAE 21UKEX1432X Sira 17ATEX1037X	Certificate: IECEX SIR 17.0015X	Certificate: TBC	

### Document Change History

See DOC-10798 for revision history

# rotork®



[www.rotork.com](http://www.rotork.com)

A full listing of our worldwide sales and service network is available on our website.

Rotork plc  
Brassmill Lane, Bath, UK  
tel +44 (0)1225 733200  
email [mail@rotork.com](mailto:mail@rotork.com)

PUB132-002-00  
Issue 03/22

As part of a process of on-going product development, Rotork reserves the right to amend and change specifications without prior notice. Published data may be subject to change. For the very latest version release, visit our website at [www.rotork.com](http://www.rotork.com)

The name Rotork is a registered trademark. Rotork recognises all registered trademarks. Published and produced in the UK by Rotork. POLTG0222